

Raymarine®



LIGHTHOUSE 3

VERSION 3.14

Advanced operation instructions

Trademark and patents notice

Raymarine, Tacktick, Clear Pulse, Truzoom, SeaTalk, SeaTalk^{hs}, SeaTalkng, and **Micronet**, are registered or claimed trademarks of Raymarine Belgium.

FLIR, YachtSense, DockSense, LightHouse, DownVision, SideVision, RealVision, HyperVision, Dragonfly, Element, Quantum, Axiom, Instalert, Infrared Everywhere, The World's Sixth Sense and **ClearCruise** are registered or claimed trademarks of FLIR Systems, Inc.

All other trademarks, trade names, or company names referenced herein are used for identification only and are the property of their respective owners.

This product is protected by patents, design patents, patents pending, or design patents pending.

Fair Use Statement

You may print no more than three copies of this manual for your own use. You may not make any further copies or distribute or use the manual in any other way including without limitation exploiting the manual commercially or giving or selling copies to third parties.

Software updates



Check the Raymarine website for the latest software releases for your product.
www.raymarine.com/software

Product documentation



The latest versions of all English and translated documents are available to download in PDF format from the website: www.raymarine.com/manuals.
Please check the website to ensure you have the latest documentation.

Publication copyright

Copyright ©2021 Raymarine UK Ltd. All rights reserved. No parts of this material may be copied, translated, or transmitted (in any medium) without the prior written permission of Raymarine UK Ltd.

Contents

Chapter 1 Important information	19
Electronic chart data.....	20
Open source license agreements	20
Regulatory approvals	20
Warranty registration.....	20
Technical accuracy.....	20
Chapter 2 Document and product information	21
2.1 Product documentation.....	22
Applicable software version	22
Compatible MFDs	22
New software features.....	23
User manuals Print Shop	24
Chapter 3 General information	25
3.1 MFD and LightHouse third-party apps	26
3.2 Sidebar	27
Customizing data sidebars	27
Switching sidebars.....	28
Enable rudder bar.....	28
3.3 Data overlays	29
Data overlay and Sidebar data items.....	29
3.4 Menus	34
Controls and settings.....	35
3.5 MFD app settings menu	36
3.6 Editing the split ratio of a Splitscreen app page	36
Chapter 4 Set up	37
4.1 MFD physical buttons	38
RMK controls.....	39
4.2 Axiom and Axiom XL.....	40
Powering on the display	40
Powering off the display	41
Switching on and off at the breaker.....	41
4.3 Axiom Pro, eS Series and gS Series	41
Powering on the display	41
Powering off the display	42
4.4 Switching on and off at the breaker.....	42
4.5 Getting started.....	42
First power up.....	42
First power up Data master selection	43
Startup wizard.....	43

First power up Limitation on Use acknowledgement	43
Multiple data sources (MDS)	43
Data sources menu	44
Identifying engines	44
Configuring Transducer settings	45
RealVision™ 3D AHRS calibration.....	46
Transducer calibration (iTC-5).....	47
Assigning a function to the User Programmable Button (UPB).....	49
Performing a settings or factory reset.....	49
Importing user data.....	49
4.6 Shortcuts	50
Taking a screenshot	50
Activating touchlock	50
Radar standby.....	51
Eject SD card	51
Disabling all sounders.....	51
Autopilot shortcuts.....	51
Bluetooth volume control	51
Adjusting brightness	52
Display mode.....	52
4.7 Memory card compatibility.....	53
Removing MicroSD card from its adaptor.....	53
Inserting a MicroSD card — Axiom variants.....	54
Inserting a MicroSD card — Axiom Pro variants.....	54
Inserting external storage devices - RCR.....	55
4.8 Software updates	56
Updating software using a memory card.....	56
Updating software via the internet	56
4.9 Device pairing.....	57
Pairing a RMK remote keypad	57
Pairing with a Quantum Radar scanner	57
Pairing a Bluetooth speaker	57
Chapter 5 Homescreen	59
5.1 Accepting the Limitations on Use	60
5.2 Homescreen overview	60
5.3 MFD Apps.....	61
5.4 Creating / Customizing an App page.....	63
5.5 User profiles.....	64
Demo profiles	65
5.6 Status area	66
Status area icons	67

5.7 Global positioning	68
Global Navigation Satellite System (GNSS) constellations	68
Satellite based augmentation systems (SBAS)	69
GNSS (GPS) Status	70
GNSS (GPS) Settings.....	71
5.8 My data.....	72
Fuel/trip manager	73
Files	75
View PDFs	75
Import/export.....	75
5.9 Alarms.....	77
Alarm manager	77
Alarm settings.....	79
External alarm speaker / buzzer	80
Acknowledging alarms	80
Digital switching alarms	81
5.10 Man Overboard (MOB).....	81
MOB mode.....	82
5.11 DSC VHF radio integration	82
5.12 Settings	83
Selecting display language.....	84
Boat details.....	85
Units of measure.....	88
Data master	89
Shared Brightness	89
Customizing the splashscreen.....	91
NMEA 0183 settings.....	92
5.13 Connecting to a wireless display.....	92
Disconnecting a wireless display.....	93
Unpairing a wireless display	93
Chapter 6 Autopilot control	95
6.1 Commissioning - Evolution autopilot system.....	96
Commissioning pre-requisites	96
Commissioning steps.....	96
Vessel hull type selection	96
Using the Dockside wizard.....	97
Compass linearization — Evolution autopilots.....	100
Compass lock	102
6.2 Autopilot control.....	102
Engaging the autopilot — Locked heading.....	103
Engaging the autopilot — Navigation	103

Engaging and disengaging the autopilot - physical buttons.....	104
Disengaging the autopilot	104
6.3 Pilot sidebar	104
6.4 Pilot pop-up.....	106
6.5 Autopilot Control — Pilot set-up menu	106
6.6 Rudder damping levels and deadband angles	109
Adjusting the Rudder Damping level.....	109
Chapter 7 Waypoints, Routes and Tracks	111
7.1 Waypoints	112
Placing a waypoint.....	112
Waypoint management.....	112
7.2 Routes	114
Creating a Route	114
Autoroute.....	115
Importing a route	117
Route management	117
7.3 Tracks	118
Creating a track	119
Converting a track to a route	119
Track management.....	119
Chapter 8 Chart app	121
8.1 Chart app overview.....	122
Chart app controls	123
Chart ranging and panning	123
Chart app context menu	124
Selecting a chart card.....	124
Chart modes	124
Vessel details.....	126
Object selection and information.....	126
Layers	128
View and motion.....	128
Camera tracking	129
8.2 Cartography overview	129
Supported charts	130
LightHouse charts.....	130
S-63 Encrypted Charts.....	133
8.3 Navigation	138
Navigating to a waypoint or point of interest.....	138
Restarting cross track error (XTE)	138
Following a Route	138
Following from here.....	138

8.4	Depths and contours	139
	Depth soundings	139
	Depth contours	140
8.5	Target tracking	142
	AIS targets	143
	AIS target information	145
	Accessing target options	146
	AIS target options	146
	AIS target list.....	147
	AIS settings menu.....	147
	Radar targets	147
	Acquiring a target manually	148
	Accessing target options	148
	Radar target options	149
	Radar target list.....	149
	Radar settings.....	150
	Target vector settings.....	151
8.6	Collision avoidance.....	151
	Dangerous targets alarm	152
	Predicted areas of danger	152
	Obstruction alarm (LightHouse charts)	161
	LightHouse charts dangerous objects.....	162
8.7	Target intercept.....	163
8.8	Tides mode	164
	Using animation controls	165
	Setting a specific date for animations.....	165
	Tide station information	166
	LightHouse charts dynamic tide graphic	167
	Navionics dynamic tide graphic.....	167
	Current station information	167
	LightHouse Charts dynamic current graphic	168
	C-Map dynamic current graphic.....	169
	Navionics dynamic current graphic	169
	Displaying tide or current graphs	169
8.9	RealBathy™	170
	Setting up and creating RealBathy contours	171
8.10	Find nearest.....	171
8.11	Measure	173
	Measuring vessel to point.....	174
	Measuring point to point.....	174
	Deleting rulers	175
8.12	SAR (Search and Rescue) patterns.....	175

Sector search pattern	175
Expanding square search pattern.....	179
Creeping line / Parallel line search pattern.....	182
8.13 Laylines	184
Sailing data page	185
Laylines — system requirements	185
Enabling Laylines.....	185
Laylines settings	186
Displaying and interpreting laylines.....	187
Displaying wind shift data	188
8.14 Race Start Line (SmartStart) and Race Timer	189
Creating the Race Start Line	190
Starting the Race Timer	192
Race laylines.....	192
Race sidebar.....	193
Dashboard	194
8.15 ClearCruise™ Augmented Reality.....	194
Field of View	195
8.16 UAV Chart integration	196
Showing or hiding the UAV icon.....	197
Performing a UAV Goto	197
8.17 SonarChart™ Live	197
Enabling SonarChart Live	198
8.18 Chart settings menu	198
Chapter 9 First responder	207
9.1 First responder configuration	208
Responder setup	208
9.2 Data logging	210
9.3 Intel targets	211
Creating an Intel target.....	211
Accessing target options	212
Intel target options.....	212
Intel target list	212
9.4 DSC targets.....	213
Accessing target options	213
DSC target options	213
DSC target list.....	214
9.5 Target Of Interest (TOI).....	214
OneShot TOI decay times.....	215
TOI OneShot settings	216
TOI transmission rates	217

TOI cancellation repeat	217
TOI position updates	217
Accessing target options	217
TOI options	218
TOI list.....	218
9.6 First responder AIS modes	219
AIS mode status icons	220
Blue Force Tracking.....	220
9.7 SITREP (Situation report)	220
9.8 SAR pattern receipt.....	222
9.9 Messaging.....	222
Message inbox.....	223
New broadcast.....	223
New direct message	223
Reply to messages.....	224
Onscreen keyboard	224
Message symbols	225
Chapter 10 Weather mode	227
10.1 Weather mode	228
10.2 Activating your SiriusXM receiver.....	229
SR200 diagnostics mode	229
Weather receiver status.....	229
10.3 Animated weather	230
10.4 Weather mode context menu.....	231
10.5 Weather Radar layer.....	231
10.6 Cities and Surface observation stations layers.....	233
10.7 Cloud top and Lightning layers	234
10.8 Storm cast and Storm tracks layers.....	235
10.9 Sea surface temperature and Surface pressure layers	236
Surface pressure patterns	237
10.10 Wind and Watchbox layers	238
10.11 Wave direction, height and period layers	239
Chapter 11 Fishfinder app.....	241
11.1 Fishfinder app overview.....	242
Fishfinder app controls	242
RealVision 3D controls.....	243
11.2 Opening the Fishfinder app.....	244
11.3 Sonar channels.....	246
Selecting a Sonar channel.....	247
11.4 Placing a Waypoint (Sonar, DownVision and SideVision).....	247
Placing a waypoint RealVision 3D	247

11.5 Sonar scroll back	248
11.6 Sonar sensitivity controls	249
11.7 Fishfinder settings menu.....	250
Chapter 12 Radar app	255
12.1 Radar app overview.....	256
Radar app controls.....	256
Radar app context menu	257
Camera tracking	258
12.2 Radar feature comparison	258
Compatible Radar scanners.....	261
12.3 Opening the Radar app.....	261
Putting the radar into standby	262
Powering down your radar scanner.....	262
12.4 Set up	263
Selecting a Radar scanner.....	263
Dual range	263
Timed Radar transmission	264
Setting open array antenna size.....	264
Bearing alignment.....	264
12.5 Radar modes	264
12.6 Range and bearing	266
VRM (Variable Range Marker) / EBL (Electronic Bearing Line).....	266
12.7 AIS targets.....	268
AIS target list.....	268
AIS targets	269
AIS settings menu.....	272
12.8 Radar targets	273
Radar target acquisition data source requirements.....	273
Radar targets	273
Acquiring a target manually.....	274
Automatic target acquisition	275
Radar target list.....	276
Target settings.....	277
Onscreen target settings	279
Clearing / resetting trails.....	279
Target context menu	279
12.9 Dangerous targets alarm	280
12.10 Guard zone alarms	280
12.11 Doppler Radar overview.....	282
Doppler mode.....	282
Doppler data source requirements.....	283

12.12 Blank sectors.....	283
12.13 Radar sensitivity controls.....	284
12.14 Radar settings	285
Chapter 13 Dashboard app	289
13.1 Dashboard app overview.....	290
Dashboard app controls	290
Switching data page	291
Selecting Data pages to display	291
13.2 Default data pages	291
13.3 Customizing existing Data pages	292
Data overlay and Sidebar data items.....	292
13.4 Dashboard settings menu.....	297
13.5 Navigation and Sailing dials	299
Sailing dials for laylines.....	300
Sailing data items.....	300
Race Start data items.....	301
Chapter 14 Yamaha app	303
14.1 Yamaha engine gateway selection	304
Compatible Yamaha gateways.....	304
14.2 Yamaha HDMI overview.....	304
14.3 Yamaha app overview.....	304
Requirements	305
Yamaha app controls.....	305
Switching data page	305
14.4 Customizing Data pages	305
Available data items.....	306
14.5 Engine page	309
Engines	310
Transmission	311
Status and warning indicators.....	312
Tanks	313
Engine trim.....	313
Troll mode.....	314
14.6 Settings	314
Fault codes	314
Maintenance	314
Advanced.....	315
Chapter 15 Mercury VesselView app.....	317
15.1 VesselView app overview	318
System status.....	319

Fault code history	319
15.2 VesselView Sidebar	320
Chapter 16 Video app	321
16.1 Video app overview	322
Video app pages	322
Renaming video feeds.....	323
Video app controls	323
Pan, Tilt, Zoom (PTZ) camera controls	324
16.2 Opening the Video app	324
Selecting a video feed.....	325
Dual streaming.....	325
16.3 Video app settings.....	326
16.4 Maritime (M-Series) camera compatibility.....	329
Chapter 17 ClearCruise (Object Detection / Video Analytics, and Augmented Reality)	335
17.1 ClearCruise™ features	336
17.2 Camera setup	337
Fixed camera calibration.....	338
Pan and Tilt camera calibration	339
17.3 AR200 setup for Augmented Reality.....	341
17.4 ClearCruise™ Object Detection (Video Analytics) overview.....	341
ClearCruise settings (Object Detection / Video Analytics).....	342
17.5 Augmented Reality (AR) overview	343
17.6 Augmented Reality flags	344
Selected flags	345
Goto flag	347
17.7 ClearCruise settings (Augmented Reality)	348
Range limit.....	349
17.8 Roll correction.....	350
17.9 AR200 Calibration (Linearization)	352
Magnetic deviation	352
AR200 calibration settings	352
Continual monitoring and adaptation	353
Compass lock	354
Chapter 18 Audio app	355
18.1 Audio app overview.....	356
Compatible entertainment systems	356
Audio app controls	358
Audio sidebar	360
18.2 Opening the Audio app.....	361
18.3 Getting started.....	362

Selecting an audio zone	362
Selecting an audio source	363
Muting and unmuting.....	363
Browsing for tracks	363
Browsing for stations / channels.....	363
Saving presets	364
Powering off entertainment systems	364
18.4 Audio app menu options.....	364
Audio app settings menu.....	365
Adjusting balance and fade controls	366
Adjusting multi-zone controls	367
SR200 diagnostics mode	368
Chapter 19 PDF Viewer app.....	369
19.1 PDF Viewer app overview	370
19.2 Opening PDF files.....	370
19.3 PDF Viewer controls.....	371
19.4 Searching a PDF	372
Chapter 20 UAV (Unmanned Aerial Vehicle) app	373
20.1 UAV disclaimer.....	374
20.2 UAV app overview.....	374
Compatible UAVs	375
UAV sport mode	375
UAV app settings menu.....	375
20.3 UAV pre-requisites	376
Removing the RC cable	377
UAV controller connection	377
20.4 UAV precautions.....	378
No-fly zones.....	378
20.5 Getting started	379
20.6 UAV app page.....	379
20.7 Opening the UAV app.....	380
20.8 Launching the UAV	382
20.9 Controlling the UAV in flight.....	382
20.10 Retrieving your UAV	383
20.11 Disconnect UAV remote controller from MFD.....	383
20.12 Fish on / Circle me mode	383
20.13 UAV Chart integration.....	384
Showing or hiding the UAV icon.....	385
Performing a UAV Goto	385
20.14 UAV Emergency procedures	385
Chapter 21 LightHouse third-party apps.....	387

21.1 Lighthouse app launcher	388
Lighthouse third-party apps	388
21.2 Lighthouse third-party apps - Preloaded	389
21.3 Lighthouse third-party apps - Downloadable	391
21.4 Installing Lighthouse third-party apps	391
21.5 Internet connection	391
Connecting to the internet.....	391
Wi-Fi settings	392
21.6 Bluetooth speaker set up	393
Enabling and disabling Bluetooth	393
Bluetooth Settings	393
Pairing a Bluetooth speaker	394
Bluetooth volume control	394
Chapter 22 Mobile app support	395
22.1 Raymarine mobile apps	396
22.2 Connecting an Android device to the display.....	396
22.3 Connecting an iOS device to the display.....	397
22.4 RayConnect	397
Lighthouse charts.....	398
Account settings	400
22.5 Fishidy sync	400
Enable sync.....	400
Disable sync.....	401
22.6 Navionics plotter sync	402
22.7 Controlling your MFD using RayControl.....	402
22.8 Controlling your MFD using RayRemote	403
22.9 Viewing your MFD screen using RayView.....	404
Chapter 23 Troubleshooting	405
23.1 Troubleshooting	406
23.2 Diagnostic product information.....	406
Saving product information.....	406
23.3 Power up troubleshooting	407
Performing a power on reset — Axiom™	407
Performing a power on reset - Axiom Pro.....	408
Performing a Power on Reset - eS and gS Series MFDs	408
23.4 Radar troubleshooting.....	409
23.5 GNSS (GPS) troubleshooting	410
23.6 Sonar troubleshooting.....	410
23.7 Camera troubleshooting	412
23.8 Augmented Reality (AR) Troubleshooting	415
23.9 Wi-Fi troubleshooting	416
23.10 Wireless display troubleshooting	418

23.11 Data troubleshooting	419
23.12 Touchscreen troubleshooting.....	419
Chapter 24 Technical support.....	421
24.1 Raymarine product support and servicing.....	422
Viewing product information (LightHouse™ 3).....	423
Remote Support via AnyDesk.....	424
24.2 Learning resources.....	424
Appendix A NMEA 0183 sentence support	425
Appendix B NMEA 2000 PGN support	426
Appendix C Document change history	429
Appendix D Hardware compatibility.....	437

Chapter 1: Important information



Warning: Ensure safe navigation

This product is intended only as an aid to navigation and must never be used in preference to sound navigational judgment. Only official government charts and notices to mariners contain all the current information needed for safe navigation, and the captain is responsible for their prudent use. It is the user's responsibility to use official government charts, notices to mariners, caution and proper navigational skill when operating this or any other Raymarine product.



Warning: Minimum Safe Depth, Width and Height

Depending on cartography vendor, the minimum safe settings are used during automatic route generation, they are used to restrict created routes from entering areas that are not suitable for the vessel.

Minimum safe settings are user defined calculations. As these calculations are outside of Raymarine's control; Raymarine will not be held liable for any damage, physical or otherwise, resulting from the use of the automatic route generation feature or the **Minimum safe depth**, **Minimum safe width** or **Minimum safe height** settings.



Warning: Automatic route generation

- Do NOT rely on automatically generated routes to guarantee that the route is safe to navigate. You **MUST** review the suggested route carefully and where necessary edit the route before following it.
- If a waypoint within any automatically generated route is added or moved the Automatic route generation algorithm will NOT be used, extra care should be taken to ensure that the route leg and any moved waypoints are safe to navigate.



Warning: Traffic separation

Automatic route generation features do not adhere to the Traffic Separation Schemes identified in Rule 10 of the *International Regulations for Preventing Collisions at Sea 1972* as amended.

Raymarine® therefore recommends that you do NOT use Automatic route generation to create any part of a route which will cross traffic lanes or pass near to traffic separation lines. In these situations Automatic route generation **MUST** be switched Off and the route or route leg **MUST** be built manually, ensuring compliance to the rules laid out in the above regulations.



Warning: Radar transmission safety

The radar scanner transmits electromagnetic energy. Ensure all personnel are clear of the scanner when the radar is transmitting.



Warning: Sonar operation

- NEVER operate the sonar with the transducer out of the water.
- NEVER touch the transducer face when the sonar is powered on.
- SWITCH OFF the sonar if divers are likely to be within 7.6 m (25 ft) of the transducer.

Electronic chart data

Raymarine does not warrant the accuracy of such information, and is not responsible for damages or injuries caused by errors in chart data or information utilized by the product and supplied by third parties. Use of electronic charts provided by third parties is subject to the supplier's End-User License Agreement (EULA).

Open source license agreements

This product is subject to certain open source license agreements. Copies of the license agreements can be found on the Raymarine website: www.raymarine.com/manuals.

Regulatory approvals

Regulatory approvals are available to view on your MFD from the settings menu, **Homescreen** > **Settings** > **Regulatory approvals**

Warranty registration

To register your Raymarine product ownership, please visit www.raymarine.com and register online.

It is important that you register your product to receive full warranty benefits. Your unit package includes a bar code label indicating the serial number of the unit. You will need this serial number when registering your product online. You should retain the label for future reference.

Technical accuracy

To the best of our knowledge, the information in this document was correct at the time it was produced. However, Raymarine cannot accept liability for any inaccuracies or omissions it may contain. In addition, our policy of continuous product improvement may change specifications without notice. As a result, Raymarine cannot accept liability for any differences between the product and this document. Please check the Raymarine website (www.raymarine.com) to ensure you have the most up-to-date version(s) of the documentation for your product.

Chapter 2: Document and product information

Chapter contents

- [2.1 Product documentation on page 22](#)

2.1 Product documentation

The following documentation is applicable to your product:

All documents are available to download in PDF format from the Raymarine website www.raymarine.com.

Description	Part number
LightHouse 3 Basic operation instructions	81369
LightHouse 3 Advanced operation instructions	81370
LightHouse™ 2 to LightHouse™ 3 upgrade procedure	81378
Axiom MFD Installation instructions	87298
Axiom Pro MFD Installation instructions	87319
Axiom XL MFD Installation instructions	87344
RMK-10 Remote Keypad Installation and operation instructions	81367
RMK-9 Remote Keypad Installation and operation instructions	81351

Applicable software version

Product software is updated regularly to add new features and improve existing functionality.

This handbook is applicable to MFD operating system software: LightHouse™ 3 v3.14.

Check the website to obtain the latest software and user manuals:

- www.raymarine.com/software
- www.raymarine.com/manuals

Compatible MFDs

The LightHouse™ 3 operating system is compatible with the MFDs listed below.

Software version	Compatible MFDs
LH3.12	<ul style="list-style-type: none"> • Axiom + • Axiom XL • Axiom Pro • Axiom
LH3.11 LH3.10.71 LH3.10 LH3.9 LH3.8 LH3.7 LH3.6 LH3.5	<ul style="list-style-type: none"> • Axiom XL • Axiom Pro • Axiom • eS Series • gS Series
LH3.4 LH3.3	<ul style="list-style-type: none"> • Axiom Pro • Axiom • eS Series • gS Series
LH3.2	<ul style="list-style-type: none"> • Axiom Pro • Axiom
LH3.1	<ul style="list-style-type: none"> • Axiom
LH3.0	<ul style="list-style-type: none"> • Axiom

LightHouse 3 support for eS Series and gS Series Multifunction displays

The support for upgrading older eS series and gS series multifunction displays (MFDs) has ended with the release of LightHouse 3 Version 3.12.

Systems that include eS Series and gS Series MFDs upgraded from LightHouse 2 to LightHouse 3 cannot be updated to LightHouse 3 version 3.12. To update Axiom MFDs to version 3.12 in these mixed MFD systems, you must remove the eS Series and gS Series MFDs from the same network as Axiom MFDs.

eS Series and gS Series MFDs remain compatible with LightHouse 3 versions 3.3 to 3.11.

Axiom+ variants will only run LightHouse 3 versions v3.12 onwards, and therefore these MFDs cannot exist on the same network as eS Series and gS Series MFDs.

New software features

The following new features have been added to version 3.14.88 of the LightHouse™ 3 operating system.

New features:

- New Mercury VesselView support via dedicated app: [p.317 — Mercury VesselView app](#)
- New LightHouse charts obstruction alarm: [p.161 — Obstruction alarm \(LightHouse charts\)](#)
- New GNSS constellation and SBAS selection options: [p.71 — GNSS \(GPS\) Settings](#)
- New Ping depth limit for high powered transducers: [Ping depth limit](#)
- Improved Wi-Fi connectivity with Routers configured to assign 10.x.x.x IP address ranges: [LightHouse™ version 3.14 Wi-Fi connectivity improvements](#)

New First responder features:

- New Intel target tracking: [p.211 — Intel targets](#)
- New DSC target tracking: [p.213 — DSC targets](#)
- New Targets of interest (TOI) tracking: [p.214 — Target Of Interest \(TOI\)](#)
- New Data logging feature: [p.210 — Data logging](#)
- Added ability to receive SAR patterns over STEDs messaging: [p.222 — SAR pattern receipt](#)
- Added support for legacy SITREP FIDs: [STEDS messaging transmission FIDs and checksums](#)
- Improved messaging app: [p.222 — Messaging](#)

LightHouse™ version 3.14 Wi-Fi connectivity improvements

LightHouse™ version 3.14.88 includes improvements for connectivity with Routers that issue IP addresses in the 10.x.x.x range. This improvement included changes to the IP address range issued by the MFD to devices connected over ethernet / RayNet and Wi-Fi.

When upgrading to LightHouse™ version 3.14 the following Raymarine products MUST also be upgraded to the specified software versions:

- **RMK-9 / RMK-10** — Software platform V18.xx / Software application V20.xx.
- **CP100 / CP200** — Software platform V18.xx / Software application V20.xx.
- **CP370 / CP470 / CP570** — Software platform V18.xx / Software application V20.xx.

The LightHouse V3.14.88 software download package includes the updated software for these products. Ensure that the products are connected and powered on before you start the software update process.

RVX1000 software compatibility

In conjunction with the release of LightHouse™ Version 3.14.88 the software for the RVX1000 sonar module has also been updated to version 3.14.88.

Important:

To maintain compatibility between the RVX1000 sonar module and your LightHouse™ 3 MFD, ensure both are updated to software version 3.14.88 or later.

Software for the RVX1000 is included in the v3.14 MFD software download package.

User manuals Print Shop

Raymarine provides a Print Shop service, enabling you to purchase a high-quality, professionally-printed manual for your Raymarine product.

Printed manuals are ideal for keeping onboard your vessel, as a useful source of reference whenever you need assistance with your Raymarine product.

Visit <http://www.raymarine.co.uk/view/?id=5175> to order a printed manual, delivered directly to your door.

For further information about the Print Shop, please visit the Print Shop FAQ pages: <http://www.raymarine.co.uk/view/?id=5751>.

Note:

- Accepted methods of payment for printed manuals are credit cards and PayPal.
- Printed manuals can be shipped worldwide.
- Further manuals will be added to the Print Shop over the coming months for both new and legacy products.
- Raymarine user manuals are also available to download free-of-charge from the Raymarine website, in the popular PDF format. These PDF files can be viewed on a PC / laptop, tablet, smartphone, or on the latest generation of Raymarine multifunction displays.

Chapter 3: General information

Chapter contents

- [3.1 MFD and LightHouse third-party apps on page 26](#)
- [3.2 Sidebar on page 27](#)
- [3.3 Data overlays on page 29](#)
- [3.4 Menus on page 34](#)
- [3.5 MFD app settings menu on page 36](#)
- [3.6 Editing the split ratio of a Splitscreen app page on page 36](#)

3.1 MFD and LightHouse third-party apps

Depending on your MFD variant 2 types of app may be available on your display.

MFD apps

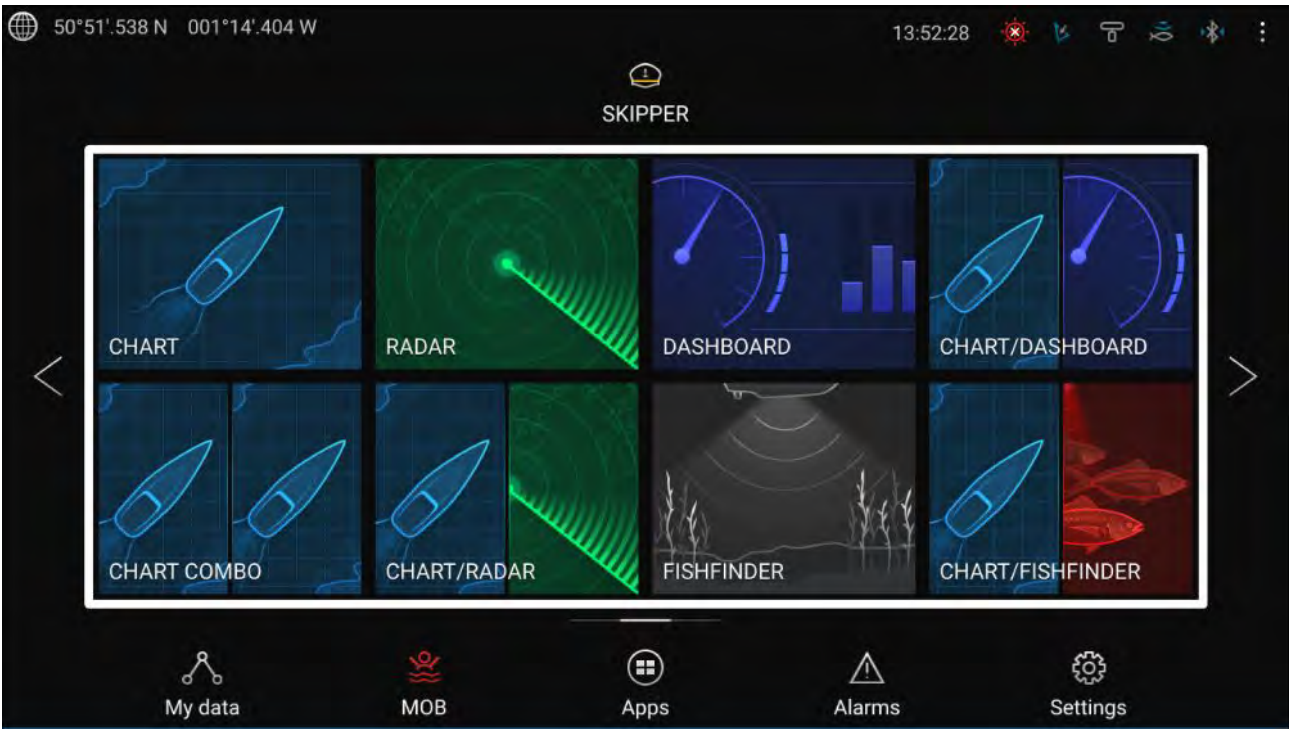

MFD apps are opened from app page icons available on the Homescreen, these apps include Chart, Radar, Fishfinder etc. MFD apps are available on all MFDs running the LightHouse™ 3 operating system. Multiple apps can be displayed simultaneously by creating splitscreen app pages.

LightHouse™ third-party apps

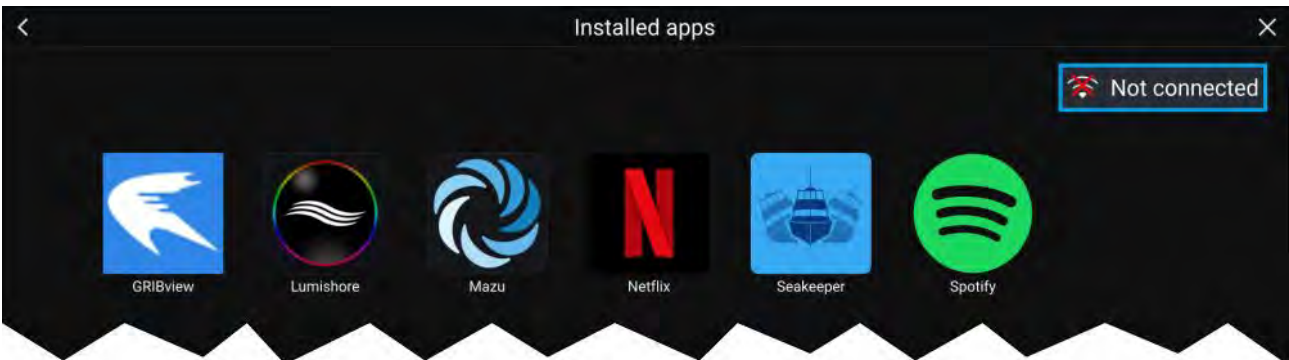

LightHouse™ third-party apps are developed entirely by 3rd parties and are approved by Raymarine. These apps are available from the LightHouse app launcher found on the Homescreen. LightHouse™ third-party apps are only available on the Axiom™ range of MFDs.

3.2 Sidebar

The Sidebar is available in all apps and provides quick access to system data. By default the Sidebar is set up to display navigation data.

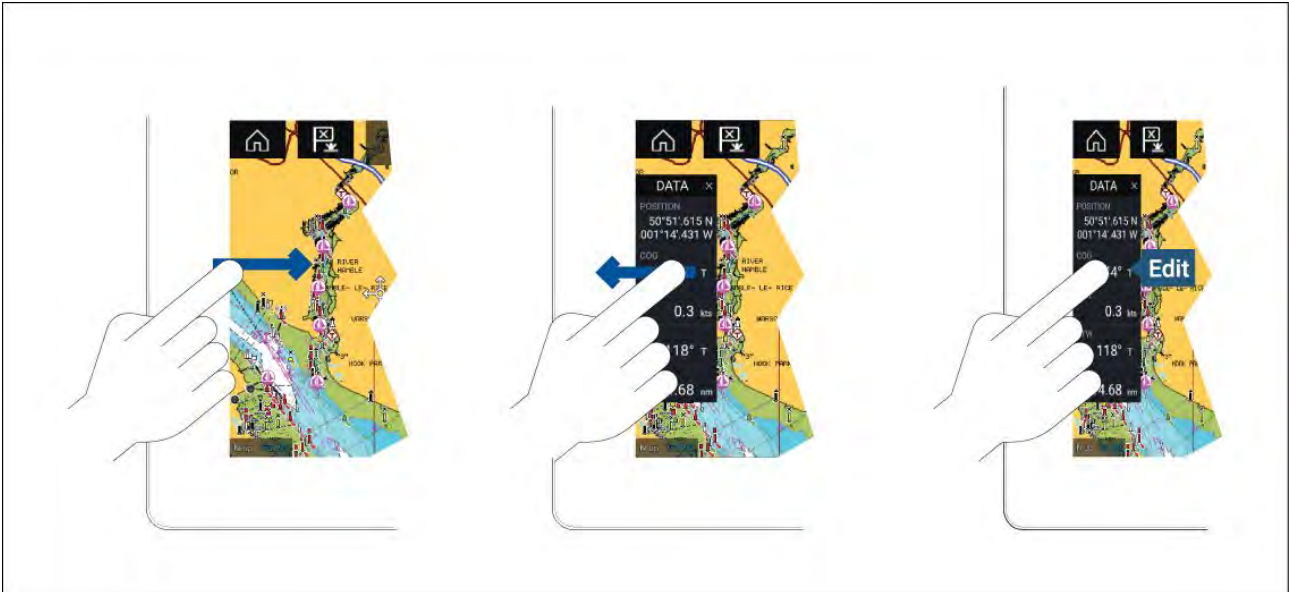

The Sidebar is displayed automatically in the Chart app when a Goto or follow is initiated. It can also be displayed at anytime by sliding your finger from left to right from the left edge of the screen. Swiping right to left will hide the Sidebar.

To customize the displayed data, press and hold on the Data item you want to change and select **Edit** from the pop-over options.

Customizing data sidebars

The data displayed in sidebars **Data 1** and **Data 2** can be customized by following the steps below.

1. Open any app and from the left edge of the screen swipe from left to right.
2. Press and hold on the data item you want to customize.
3. Select **Edit** from the pop-over menu.
4. Select the data item that you want to be displayed.

Switching sidebars

Depending on connected devices and set up, various sidebars are available.



Data 1, **Data 2** and **Search** sidebars are always available. The **Race Start** sidebar is available when a sailing vessel boat type is selected during the initial start up wizard. The **Audio** sidebar is available when compatible audio equipment is connected, and the **Pilot** sidebar is available when autopilot control is enabled.

To switch sidebars:

1. Select the **Sidebar selection** icon.
2. Select the Sidebar you want to use.
3. You can also pin the Sidebar to the app using the pin icon.

Enable rudder bar

The Rudder bar is located at the bottom of the Sidebar, it displays the position of your vessel's rudder.

Note: A rudder position sensor must be on the same network as your MFD for the Rudder bar to function.

To enable the Rudder bar:

1. Select the Sidebar selection icon.
2. Select Rudder bar to enable / disable its display at the bottom of the Sidebar.

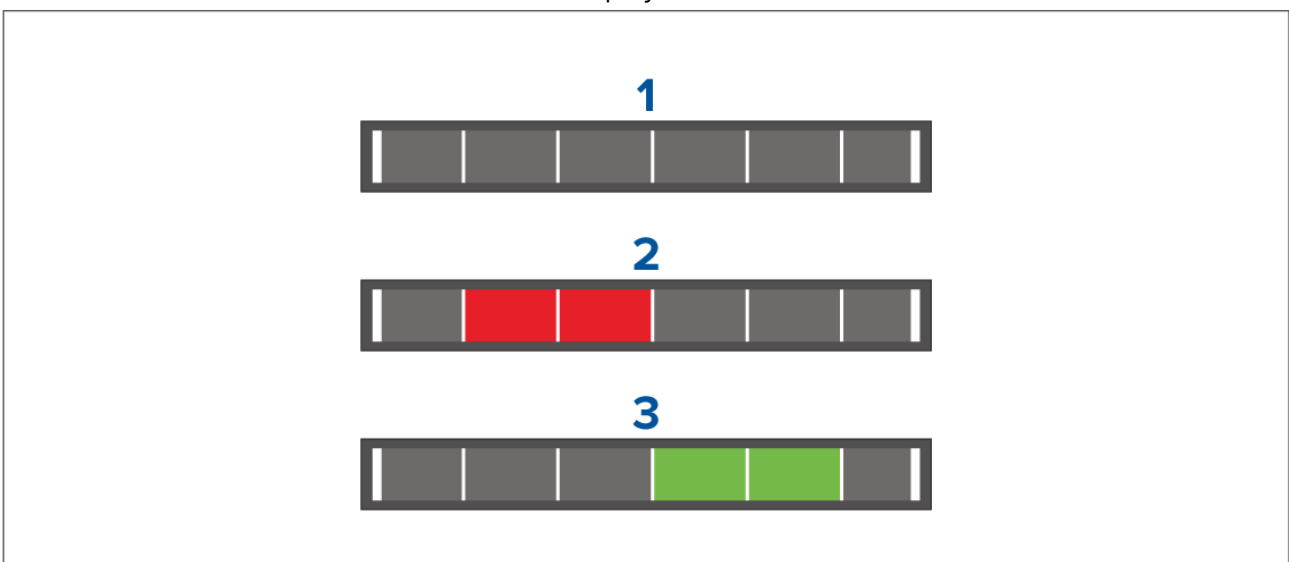

1. No rudder data found.
2. Rudder deflection to port.
3. Rudder deflection to starboard.

3.3 Data overlays

System data can be overlaid onto the Chart, Radar, Sonar or Camera apps. Some apps have Data overlays enabled by default.

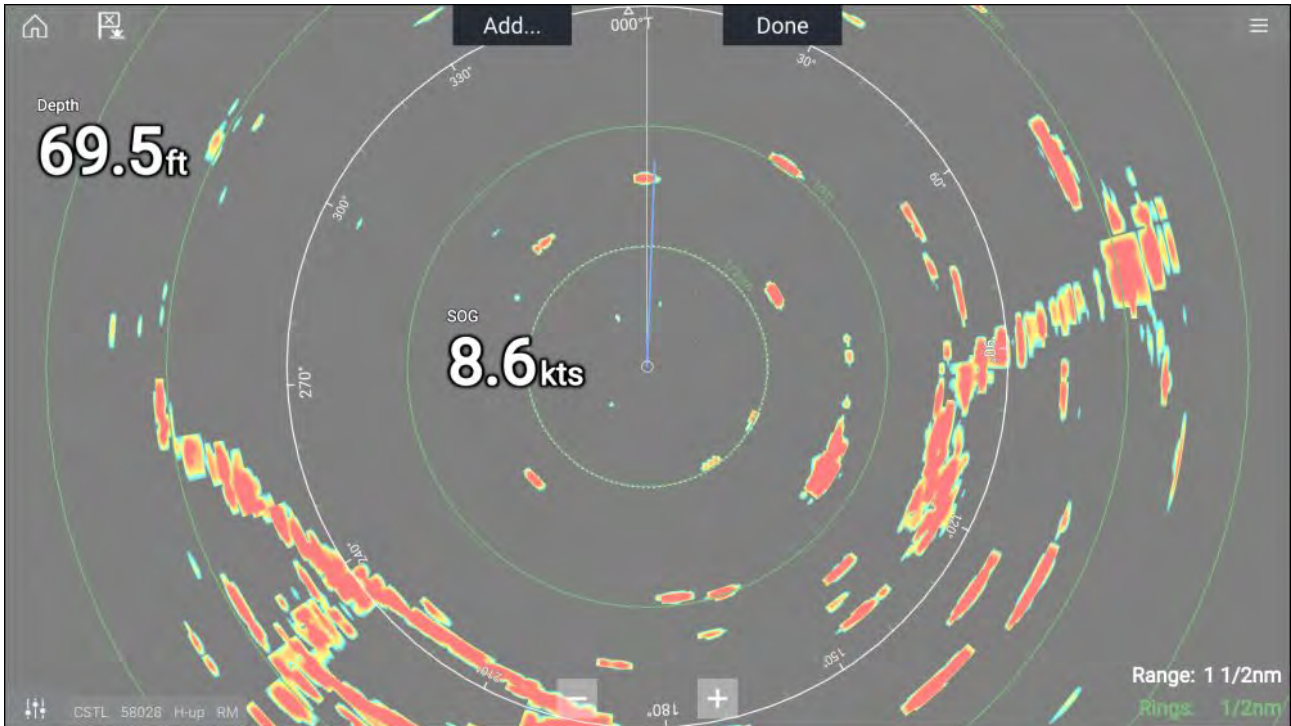

Data overlays can be placed anywhere on the app page and can be placed over any app in a Splitscreen app page.

Data overlays can be customized from: **Menu > Settings > Page Settings > Edit data overlays.**

In edit mode, drag the data overlay to the desired location. Touch and hold a Data overlay to display the pop-over menu, where you can **Edit, Move, Resize** or **Delete** the Data overlay.

Select **Add** to add another overlay or **Done** to exit edit mode.

Data overlay and Sidebar data items

The following data items are available for display in the Dashboard app, in Data overlays and Sidebars.

Note:

For data to be available compatible sensors and transducers are required to be connected to the same data network as the MFD.

Data category	Data items
<p>Battery Battery related data. Data items are available for the number of batteries specified in the Boat details settings: Homescreen > Settings > Boat details > Num of batteries.</p>	<ul style="list-style-type: none"> • Battery voltage • Battery current • Time till zero charge • Battery temperature • State of charge
<p>Boat</p> <hr/> <p>Note:</p> <ul style="list-style-type: none"> • (1) Data item is only available in the Dashboard app 	<ul style="list-style-type: none"> • Roll • Mast rotation • Rate of turn • Trim tabs⁽¹⁾
<p>Depth Depth related data.</p>	<ul style="list-style-type: none"> • Maximum depth • Minimum depth • Depth
<p>Display Data relating to the voltage supplied to the MFD.</p> <hr/> <p>Note:</p> <ul style="list-style-type: none"> • (1) Data item is only available in Sidebars and data overlays. • (2) Data item is only available in Sidebars. 	<ul style="list-style-type: none"> • Supply voltage⁽¹⁾ • Supply voltage level⁽²⁾
<p>Distance</p> <hr/> <p>Note:</p> <ul style="list-style-type: none"> • (1) Data item is only available in the Dashboard app 	<ul style="list-style-type: none"> • Distance to line • Distance to tack • Trip (manual) • Trip (month) • Trip (day) • Trip (season) • Line bias • Ground log • Trip • Log • Log Trip⁽¹⁾
<p>Engine Engine related data requires data connection to compatible vessel engine(s). Data items are available for the number of engines specified in the Boat details settings: Homescreen > Settings > Boat details > Num of engines</p>	<ul style="list-style-type: none"> • Engine trip • Trans oil temp • Fuel flow (avg) • Trans oil pressure • Gear • Engine load • Alternator • Oil temperature • Oil pressure • Engine RPM • Engine hours • Coolant temperature

Data category	Data items
	<ul style="list-style-type: none"> • Coolant pressure • Boost pressure • Fuel pressure • Fuel flow (inst) • Fuel flow • Tilt position
<p>Fuel Data related to fuel economy. An 'All tanks' category is available when more than 1 fuel tank has been specified that combines data from all fuel tanks.</p>	<ul style="list-style-type: none"> • Est. fuel remaining • Total fuel (vol) • (vol) • (%) • Total fuel (%) • Engine economy total • Time to empty • Distance to empty • Fuel flow total • Fuel used (trip) • Fuel used (season)
<p>Environment</p> <div style="background-color: #f0f0f0; padding: 5px; border: 1px solid black;"> <p>Note:</p> <ul style="list-style-type: none"> • (1) Data item is only available in the Dashboard app </div>	<ul style="list-style-type: none"> • Drift • True wind chill • App wind chill • Set • Max water temp • Min water temp • Water temp • Max air temp • Min air temp • Humidity • Dew point • Barometric pressure • Air temp • Sunset Sunrise⁽¹⁾ • Set Drift⁽¹⁾ • Water & Supply⁽¹⁾
<p>Inside Environment Data items are available for the number of interior environment sensors specified in the Boat details settings: Homescreen > Settings > Boat details > Num of interior environment sensors.</p>	<ul style="list-style-type: none"> • Inside humidity • Inside temperature



Data category	Data items
<p>GPS</p> <hr/> <p>Note:</p> <ul style="list-style-type: none"> (1) Data item is only available in the Dashboard app 	<ul style="list-style-type: none"> Cursor position Loran cursor position Loran position Vessel position SOG (Speed Over Ground) Course over ground Average SOG Maximum SOG COG SOG (Course Over Ground) (Speed Over ground)⁽¹⁾
<p>Heading</p> <hr/> <p>Note:</p> <ul style="list-style-type: none"> (1) Steer to layline is only available when boating activity is set to Sailing in the initial MFD start up wizard. (2) Data item is only available in the Dashboard app 	<ul style="list-style-type: none"> Steer to layline⁽¹⁾ Heading error Tack heading Locked heading Heading Locked heading & Error⁽²⁾ Heading & Speed⁽²⁾
<p>Navigation</p> <hr/> <p>Note:</p> <ul style="list-style-type: none"> (1) Data item is only available in the Dashboard app 	<ul style="list-style-type: none"> Sailing Wpt TTG (Waypoint Time To Go) Sailing Dist to Wpt (Distance To Waypoint) Next waypoint Loran target position Cross tack error Waypoint TTG (Time To Go) Route TTG (Time To Go) Target position Waypoint ETA (time & date) (Estimated Time of Arrival) Route ETA (time & date) (Estimated Time of Arrival) Distance to waypoint Distance made good Course made good Bearing Origin to Waypoint Bearing to waypoint Active waypoint Route ETA (Estimated Time of Arrival) Waypoint ETA (Estimated Time of Arrival) CTS & DTW⁽¹⁾ (Course To Steer & Distance To Waypoint) CMG & VMG⁽¹⁾ (Course Made Good & Velocity Made Good) BTW & DTW⁽¹⁾ (Bearing To Waypoint & Distance To Waypoint)



Data category	Data items
	<ul style="list-style-type: none"> • Waypoint info⁽¹⁾ • CMG & DMG⁽¹⁾ (Course Made Good & Distance Made Good)
Pilot	<ul style="list-style-type: none"> • Rudder angle
Speed <div style="border: 1px solid black; background-color: #f0f0f0; padding: 5px;"> <p>Note:</p> <ul style="list-style-type: none"> • (1) Polar performance is only available when boating activity is set to Sailing in the initial MFD start up wizard. </div>	<ul style="list-style-type: none"> • VMG to waypoint (Velocity Made Good) • Speed thru water • VMG to windward (Velocity Made Good) • Avg speed • Max speed • Target speed • Polar performance⁽¹⁾
Time <div style="border: 1px solid black; background-color: #f0f0f0; padding: 5px;"> <p>Note:</p> <ul style="list-style-type: none"> • (1) Data item is only available in the Dashboard app </div>	<ul style="list-style-type: none"> • Sunset time • Sunrise time • UTC date (Universal Time Coordinated) • UTC time (Universal Time Coordinated) • Race timer⁽¹⁾ • Date • Time • Time to tack • Time to burn
Wind <div style="border: 1px solid black; background-color: #f0f0f0; padding: 5px;"> <p>Note:</p> <ul style="list-style-type: none"> • (1) Data item is only available in the Dashboard app </div>	<ul style="list-style-type: none"> • True wind angle • Cardinal • Beaufort • Ground wind direction • Ground wind speed • True wind direction • Minimum true wind angle • Maximum true wind angle • Minimum true wind speed • True wind speed • Maximum app wind speed • App wind speed • Minimum app wind angle • App wind angle • Maximum app wind angle • Minimum app wind speed • Minimum true wind speed • GWD & Beaufort⁽¹⁾ (Ground Wind Direction) • GWS & GWD⁽¹⁾ (Ground Wind Speed & Ground Wind Direction) • AWA & VMG⁽¹⁾ (Apparent Wind Angle & Velocity Made Good)

Data category	Data items
	<ul style="list-style-type: none"> • AWA & AWS⁽¹⁾ (Apparent Wind Angle & Apparent Wind Speed) • TWA & VMG wind⁽¹⁾ (True Wind Angle & Velocity Made Good) • TWA & TWS⁽¹⁾ (True Wind Angle & True Wind Speed)
Fuel (Gasoline)	<ul style="list-style-type: none"> • %
Fresh water	<ul style="list-style-type: none"> • %
Live well	<ul style="list-style-type: none"> • %
Grey water	<ul style="list-style-type: none"> • %
Black water	<ul style="list-style-type: none"> • %

3.4 Menus



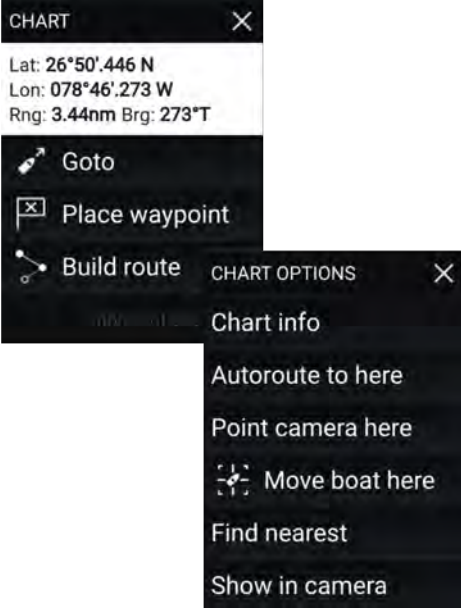

The different types of menu available in LightHouse™ 3 are shown below.

	<p>The Main menu is displayed on the right side of the screen when the Menu icon is selected.</p>
	<p>Main menu Each MFD app includes a main menu. Main menus provide access to the MFD app's features and settings, via menu options and menu pages. Selecting Back (<), Close (X) or selecting an area of the screen away from the menu, will close the menu. Selecting a menu item with a right arrow (>) will open a menu page or other menu options for that item.</p>
	<p>Menu pages Menu pages are accessed from main menu options and icons found on the Homescreen. Menu pages are fullscreen pages containing menu options and settings. Menu pages are usually set out in tabs with each tab containing options relevant to the tab's title. Selecting tab titles will display the contents for that tab. Selecting Back (<) or Close will close the menu.</p>

	<p>Context menus</p> <p>Context menus are available in MFD apps. Context menus are accessed by selecting an object or location within the MFD app.</p> <p>Context menus provide context-sensitive information and options.</p> <p>Selecting more options will display further contextual menu options.</p> <p>Selecting Close (X) or selecting an area of the screen away from the menu, will close the menu.</p>
	<p>Pop-over menus</p> <p>Pop-over menus are available on the Homescreen, in MFD apps and from Menu pages. Pop-over options provide access to further menu options and settings.</p> <p>Selecting an area of the screen away from the menu will close the menu.</p>

Controls and settings

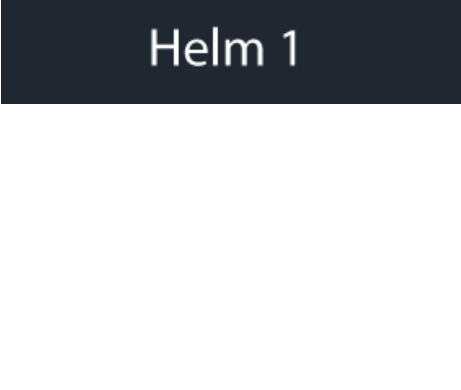
Common menu controls and options are detailed below.

	<p>Toggle switch</p> <p>Toggle switches are used to enable (switch on) or disable (switch off) various features and settings.</p> <p>When enabled (switched on) the white circle will be moved right and the switch's background will be filled Green.</p>
	<p>Page down</p> <p>Selecting will page down the current menu or page.</p> <p>When displayed you can also swipe the page to scroll up or down.</p>
	<p>Setting field</p> <p>Setting fields show the selected value for that control.</p> <p>Selecting a setting field will display the available options relevant to the options available. Depending on available options this could be in the following formats:</p> <ul style="list-style-type: none"> • Pop-over options (selection list) • Numeric value control • Onscreen keyboard • File browser • Selection list (full page)
	<p>Setting button</p> <p>Setting buttons are available on Menu pages and Notification / Alarm messages to access further settings or confirm setting changes or changed MFD state.</p>

3.5 MFD app settings menu

Each MFD app includes a settings menu that provides access to the app's settings and features.

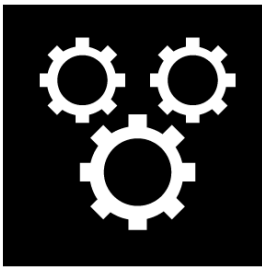

The settings menu in each MFD app is signified by the Settings icon, found in the main app menu.

3.6 Editing the split ratio of a Splitscreen app page

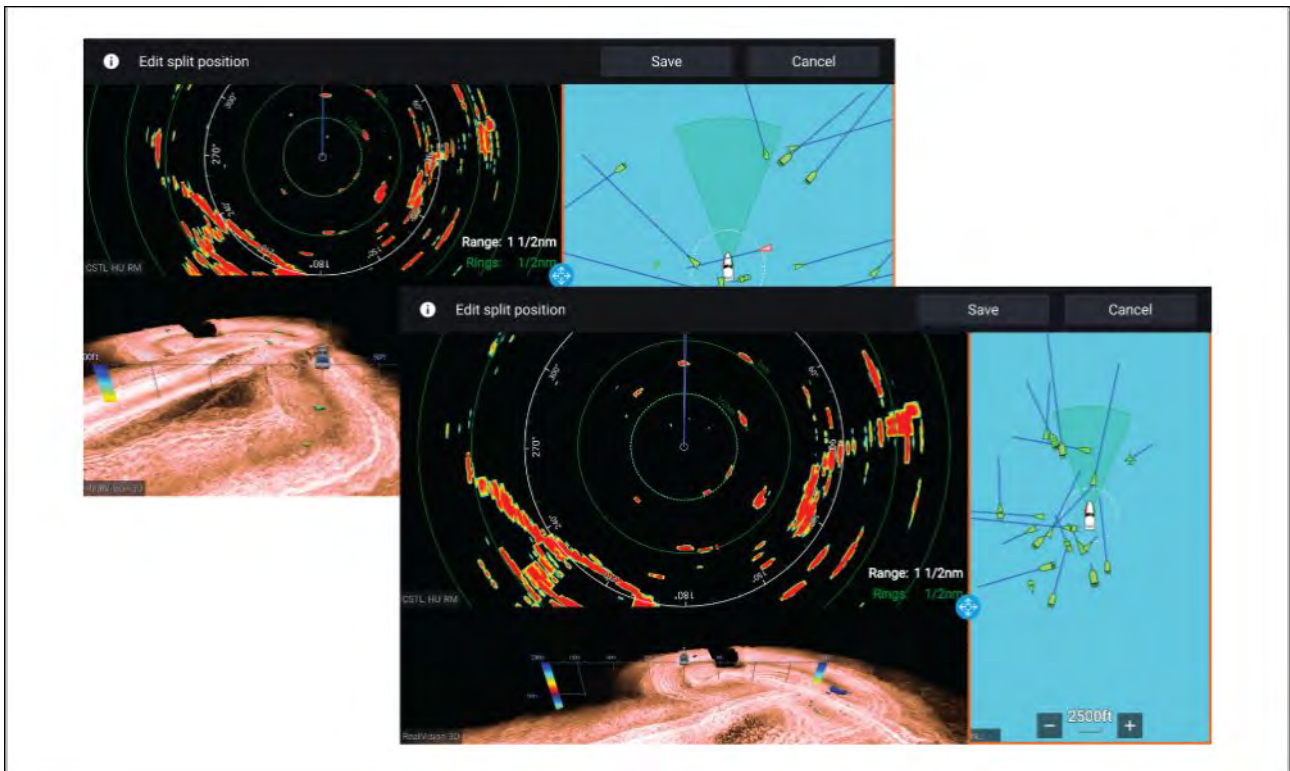

With a Splitscreen app page displayed:

1. Select **Edit split ratio** from the **Page settings** tab: **Menu > Settings > Page settings > Edit split ratio**.
2. Drag the Resize icon to create the desired split ratio.
3. Select **Save**.

Chapter 4: Set up

Chapter contents

- 4.1 MFD physical buttons on page 38
- 4.2 Axiom and Axiom XL on page 40
- 4.3 Axiom Pro, eS Series and gS Series on page 41
- 4.4 Switching on and off at the breaker on page 42
- 4.5 Getting started on page 42
- 4.6 Shortcuts on page 50
- 4.7 Memory card compatibility on page 53
- 4.8 Software updates on page 56
- 4.9 Device pairing on page 57









4.1 MFD physical buttons

The table below shows the physical buttons that are available on LightHouse™ 3 compatible MFDs and remote keypads, along with their function.

Note:

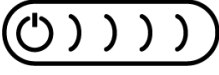
- Where 2 button symbols are shown, the symbols on the left represent Axiom™ Pro variant MFDs or RMK-10 keypad, and the symbols on the right represent an eS Series MFD or RMK-9 keypad.
- Axiom MFDs and gS Series MFDs only have a single power button.

Physical MFD buttons

Control	Button	Function
	Home	Press to display the Homescreen.
	Menu	Press to open or close menus.
	⁽¹⁾ User Programmable Button (UPB)	You can select which function this button controls. Refer to Assigning a function to the User Programmable Button (UPB) for more information.
	Waypoint / MOB	Press momentarily to place a waypoint at your vessel's location. A long press activates the Man overboard (MOB) alarm.
	Power	Press to power on the MFD. When the MFD is powered on, pressing this button displays the Shortcuts page.
	⁽²⁾ Power swipe	Swipe to power on the MFD. When the MFD is powered on, swipe again to display the Shortcuts page.
STBY Standby (Auto) (Auto)	Pilot	Press momentarily to display or hide the Pilot sidebar. A long press engages the autopilot in locked heading mode, or disengages an active autopilot.
	Switch	Press momentarily to switch the active pane in a splitscreen page. A long press expands the selected pane.
	Back	Press to return to the previous menu or dialog.
	Range In	Press to Range or Zoom In.

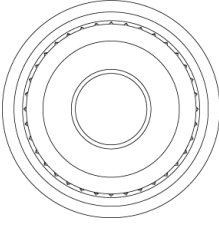
Control	Button	Function
	Range Out	Press to Range or Zoom Out.
	Uni-controller	The Uni-controller consists of a center OK button, Directional controls and a Rotary knob.

MFD Uni-controller

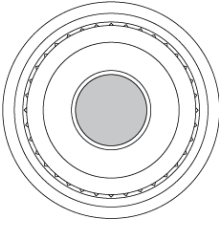
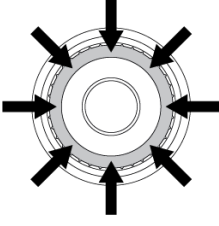
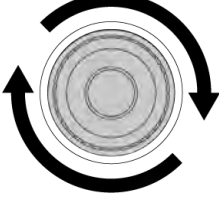
Control	Control	Function
	Ok	Push the button to confirm a selection.
	Directional	Use the 8-way directional controls to reposition the cursor onscreen.
	Rotary	Turn clockwise to Range or Zoom In and counterclockwise to Range or Zoom out.

Note:

- ⁽¹⁾ The UPB is only available on Axiom™ Pro MFDs.
- ⁽²⁾ The Power swipe is only available on Axiom™ MFDs.

RMK controls

LightHouse™ 3 MFDs can be controlled remotely using an RMK-9 or RMK-10.

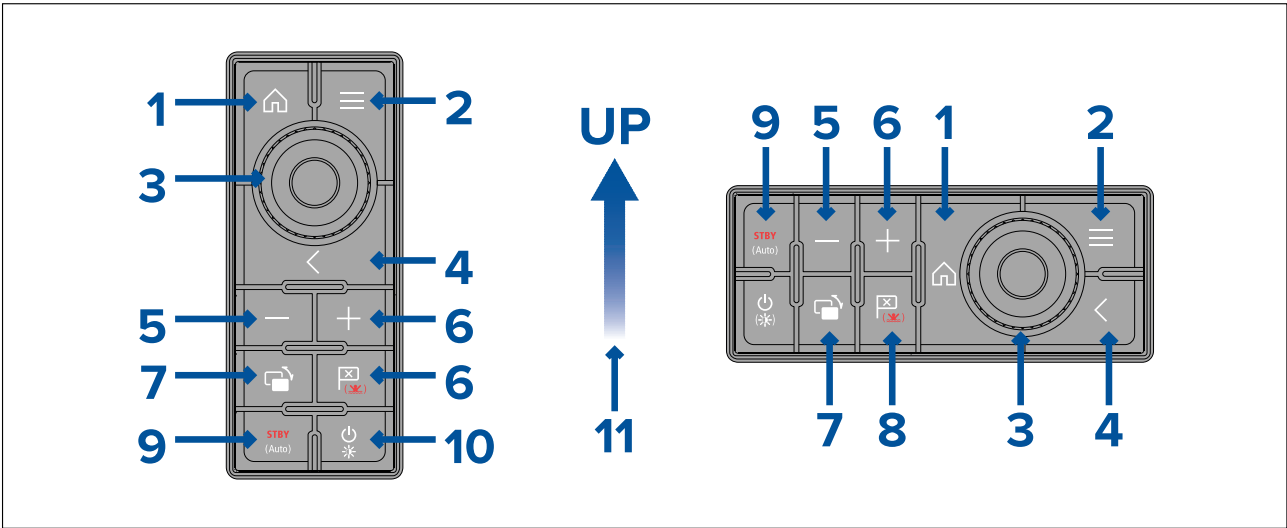

1. **Home** — press to return to the Homescreen.
2. **Menu** — accesses menus. Press again to close menus.
3. **UniController** — provides a rotary control and a joystick that includes an **OK** push button for using menus and applications.
4. **Back** — press to return to a previous menu or dialog level.
5. **-** (Minus/Negative symbol) — press to range out.
6. **+** (Plus/Positive symbol) — press to range in.
7. **Active** — press to switch the active pane, or to switch the active multifunction display (in multiple display systems).
8. **Waypoint / MOB** — press and release to access the waypoint options. Press again to place a waypoint. Press and hold to place a Man Overboard (MOB) marker at your current position.
9. **Standby (Auto)** — press to disengage integrated autopilot, press and hold to activate Auto mode on integrated autopilot.

10. **Power** — see table below:

Configuration	Display State	Momentary press	Press and hold
Single MFD	Off	Not applicable	Not applicable
	On	Open Shortcuts page	Power off / put into Standby
Multiple MFDs	All displays Off	Not applicable	Not applicable
	All displays On	Open Shortcuts page on active display	Power down all displays
	1 Display On and 1 display Off	Open Shortcuts page on active display	Power down active display

Note: MFDs that are powered off must be switched back on using the MFD's **Power** button.

11. Direction of Joystick Up.

4.2 Axiom and Axiom XL

Powering on the display

When power is available to the MFD but the MFD is switched off, the Power symbol will be illuminated. To power on the display:

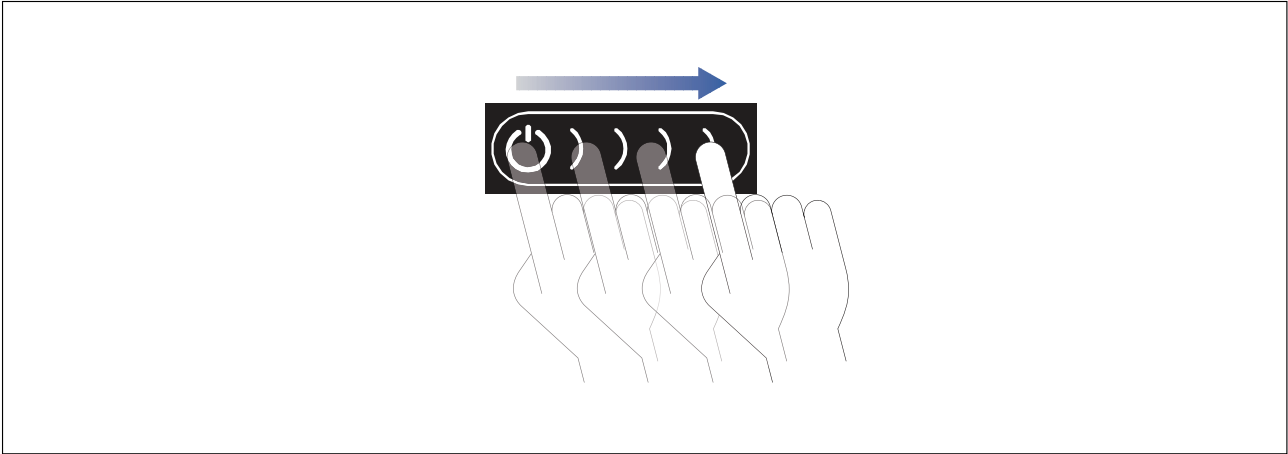

1. Swipe your finger from left to right across the **Power** button swipe area.
The MFD will power up.

Powering off the display

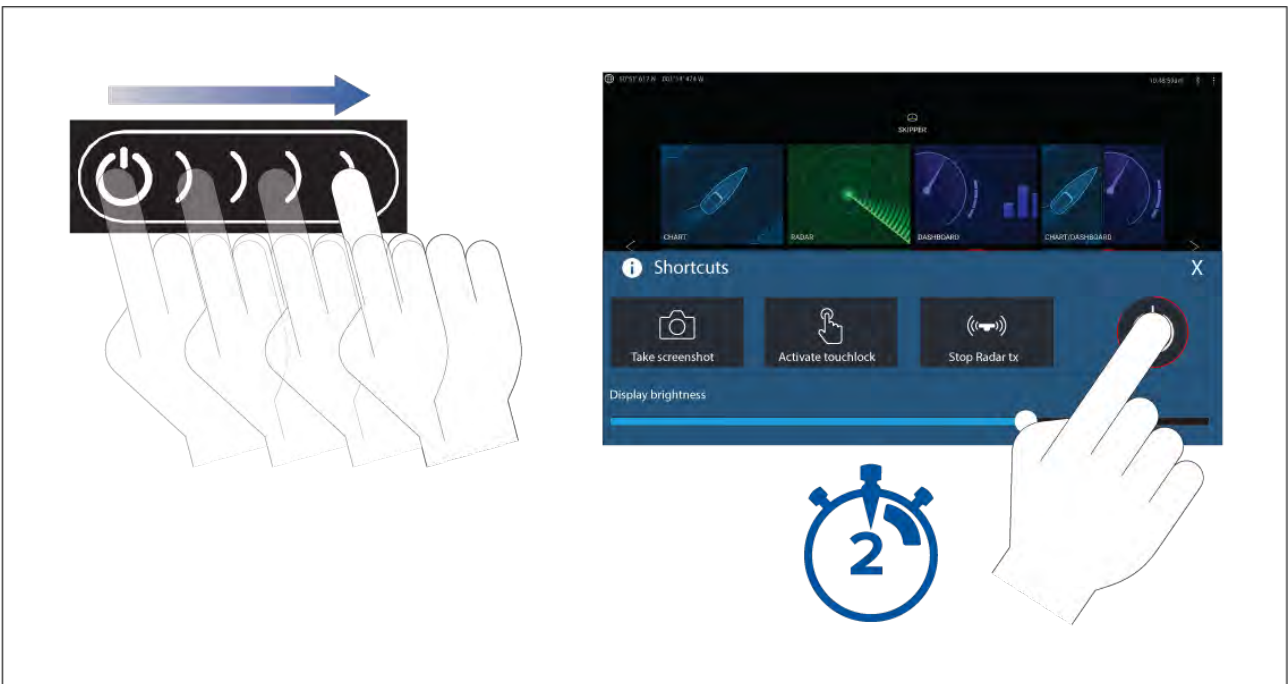

1. Swipe your finger from left to right across the **Power** button swipe area.
The Shortcuts menu is displayed.
2. Press and hold the **Power symbol** until the screen switches off.

Note:
When powered off, the unit may still draw a small amount of power from the battery. If this is a concern, unplug the power supply or switch off at the breaker.

Switching on and off at the breaker

If you wish to ensure that the MFD is not consuming any power then it must be switched off at the breaker or have the power cable unplugged.

When the breaker is switched back on, or the cable is reconnected, the MFD will resume in the same power state that it was in when it was switched off.

4.3 Axiom Pro, eS Series and gS Series

Powering on the display

1. Press the power button to power on the display.

Powering off the display

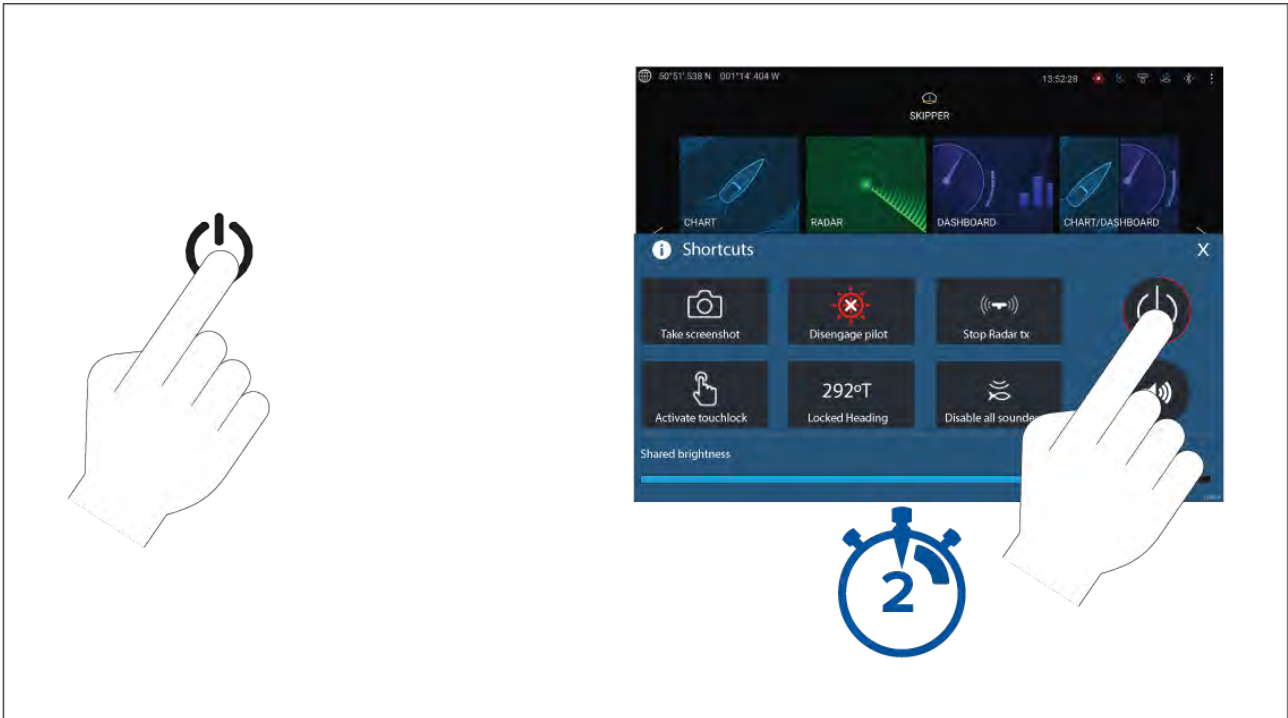

1. Press the **Power** button.
2. From the Shortcuts page press and hold the power icon for approximately 2 seconds.

Alternatively you can press and hold the **Power** button for approximately 6 seconds to power off your display.

Note:

When powered off, the unit may still draw a small amount of power from the battery. If this is a concern, unplug the power supply or switch off at the breaker.

4.4 Switching on and off at the breaker

If you wish to ensure that the MFD is not consuming any power then it must be switched off at the breaker or have the power cable unplugged.

When the breaker is switched back on, or the cable is reconnected, the MFD will resume in the same power state that it was in when it was switched off.

4.5 Getting started

First power up

When you power up your new Multifunction Display (MFD) for the first time a number of actions are required.

The list below shows the actions that should be performed on your new MFD:

1. **Power** on the display.
2. Select your **Data master** (only required on networks with more than 1 MFD).
3. Complete the **Startup wizard** (the wizard will not be shown if you are connecting to an existing system that has already been set up).
4. Read and agree to the **Limitations on Use** disclaimer.
5. Select/check your preferred **Data sources**, if required.
6. Perform **Engine identification**, if required.
7. Select/check **Transducer settings**, if required

First power up Data master selection

Networks containing more than 1 MFD must have a designated Data master. The Data master is the primary MFD in the network and should be the MFD that is connected to the SeaTalkng® / NMEA 2000 CAN bus network and any other devices and sources of data in your system. The Data master bridges the data over the SeaTalkhs™ network to any compatible networked 'repeater' MFDs.

By default your MFD will be set as a Data master. If you are connecting to a network that already includes MFDs then on first power up you will be requested to confirm your Data master.

The "Multiple Data masters found" warning will be displayed whenever a new MFD is added to your network.

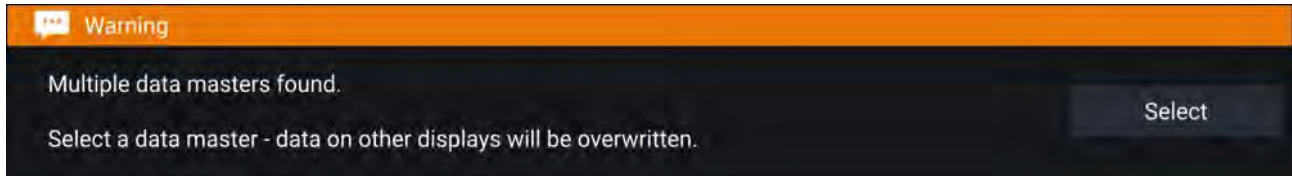

You can change your Data master at anytime by selecting **Assign as Data master** against a MFD listed in the Network tab of the Settings menu: **Homescreen > Settings > Network**.

Startup wizard

If the MFD is being installed as a stand alone installation or as part of a new system, then the first time the MFD is powered up the Startup wizard will be displayed. The Startup wizard will help you configure important settings on your MFD.

Follow the onscreen instructions and configure the relevant settings.

The Startup wizard will also be displayed after a **Factory reset** is performed.

First power up Limitation on Use acknowledgement

After you have completed the Startup wizard the Limitation on Use (LoU) disclaimer is displayed.

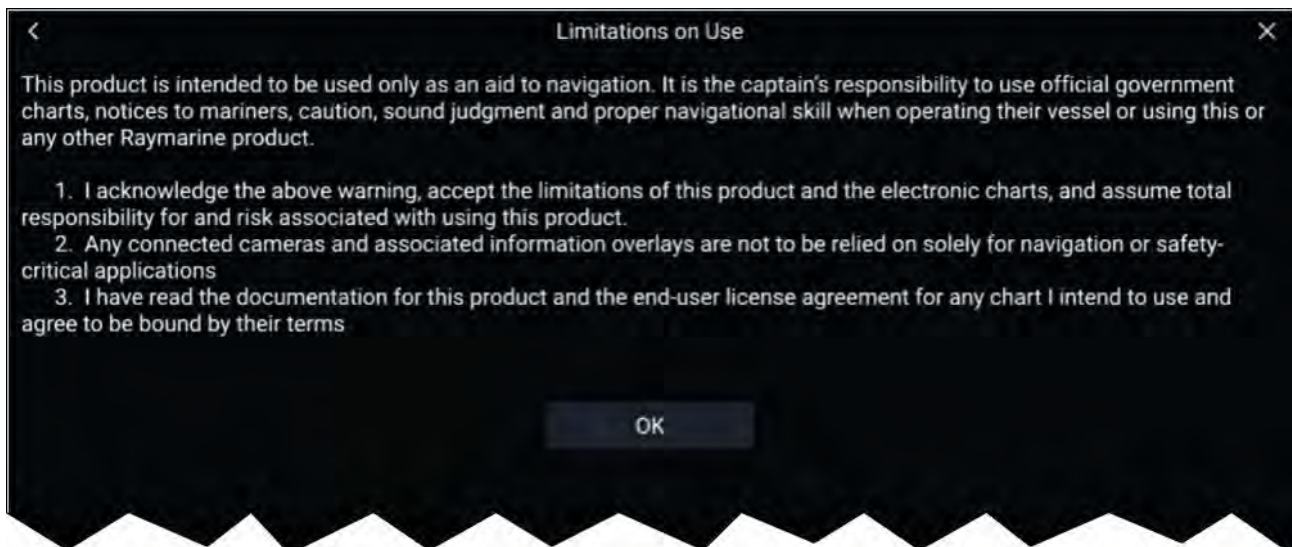

You must read and agree to the terms in order to use your MFD.

Selecting **OK** means you have accepted the terms of use.

Multiple data sources (MDS)

MDS is a Raymarine scheme for managing multiple sources of identical data types on the same network (e.g.: in an MFD network you may have more than one source of GPS / GNSS position data).

The MFD will automatically select a preferred data source (device) to use for that data type.

MDS can be used for the following data types:

- Depth
- Speed through water
- Heading
- GPS

- GPS Datum
- Wind
- Time & Date

If you do not want to use the automatically selected data source you can manually select your preferred data source.

Note:

For MDS to be available on your system, all products in the system that report data must be MDS-compliant. The system will report any products that are NOT MDS-compliant. It may be possible to upgrade the software for these non-compliant products, to make them compliant. Visit the Raymarine website (www.raymarine.com) to obtain the latest software for your products.

If MDS-compliant software is not available for the product and you do NOT want to use the system's preferred data source, you must remove any non-compliant products from the system. You should then be able to select your preferred data source.

Once you have completed setting up your preferred data sources, you may be able to add non-compliant products back into the system.

Data sources menu

When a system includes multiple sources of an MDS compatible data type the system will choose the most appropriate source for the data. If you prefer, you can manually select your own data source.

The **Data sources** menu can be accessed on your Data master MFD, from the **Settings** menu: **Homescreen > Settings > Network > Data sources**.

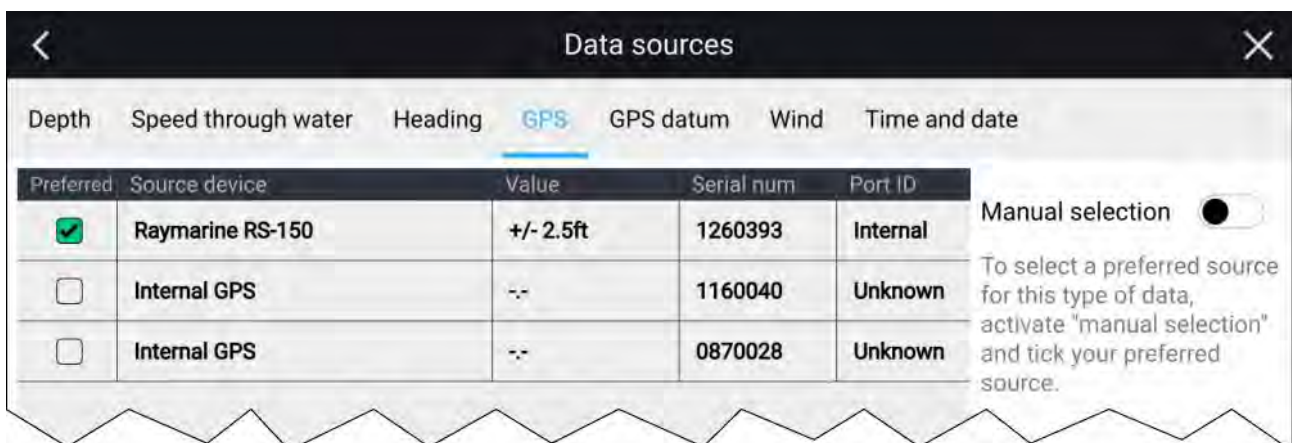

Each menu tab enables you to view the available data sources and, if required, manually select your preferred data source. The currently active data source will be ticked and display its current value in use.

To manually select a data source, enable the **Manual selection** toggle switch and then select your preferred data source from the list.

Networked MFDs will automatically be updated to use the Data sources selected on your Data master MFD.

Select the **Refresh** button at the bottom of the screen to refresh the list.

Identifying engines

Engine data can be shown on your display, if your engines are transmitting the relevant supported data on the same network as your display. If your system has mislabelled your engines then you can correct this using the Engine identification wizard.

The Engine identification wizard can be accessed from the Boat details menu: **Homescreen > Settings > Boat details > Identify engines**.

1. Ensure the correct number of engines is selected in the **Num of Engines:** box.
2. Select **Identify engines**.
3. Follow the onscreen prompts to complete the engine identification wizard.

Configuring Transducer settings

For systems set up with Sonar, you should configure your transducer settings.

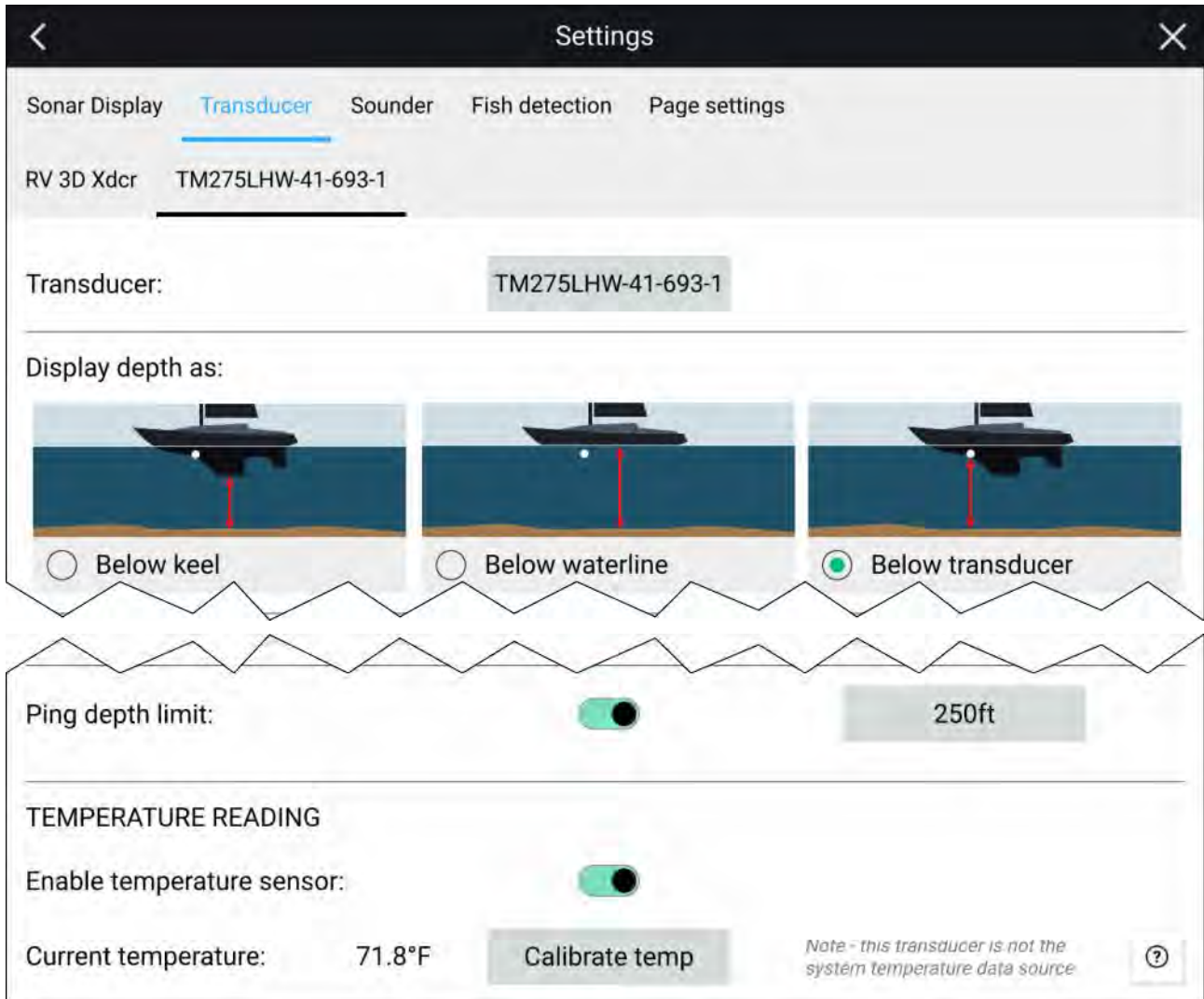

1. Select **Transducer** from the Fishfinder app's **Settings** menu: **Menu > Settings > Transducer**
2. Select how you want your depth to appear:
 - i. Below transducer (default) — No offset required
 - ii. Below keel — Enter the distance between the transducer face and the bottom of the Keel.
 - iii. Below waterline — Enter the distance between the bottom of your Keel and the waterline.
3. If your transducer includes a temperature sensor then you can also configure temperature settings as follows:
 - i. Enable or disable temperature readings as required.
 - ii. If enabled, check the temperature reading against the actual water temperature.
 - iii. If the current reading requires adjustment, select **Calibrate temp** and enter the difference between your 2 readings.

Ping depth limit

When high powered transducers are searching for a bottom lock they can search down to a maximum of 3,048 m (10,000 ft) during its hunt cycle this means it can take some time to acquire or re-acquire a bottom lock. To help improve sonar bottom lock re-acquisition time on high powered transducers a ping depth limit can be set.

When using a CHIRP or non-CHIRP high power (greater than 600 W) transducer connected to the 1 kW transducer connector on an Axiom™ Pro MFD or RVX1000 sonar module the **Ping depth limit** control will be available in the Fishfinder app's Transducer settings menu: **Menu > Settings > Transducer > Ping depth limit.**

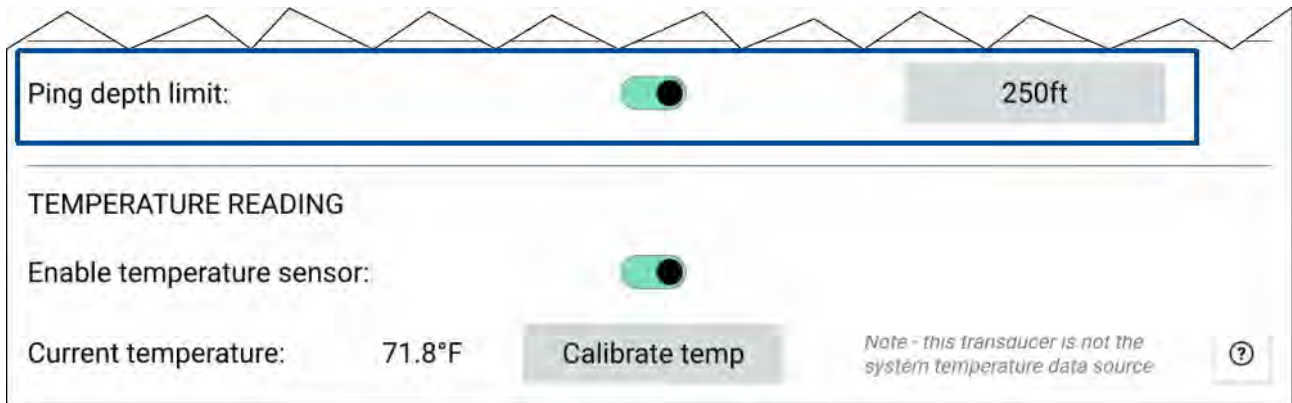

Important:

- The **Ping depth limit** should only be enabled when problems are experienced re-acquiring depth readings after the sonar has lost depth readings.
- Once **Ping depth limit** is enabled, when sailing in waters deeper than the specified depth limit the Fishfinder app / transducer will not be able to establish a depth reading / bottom lock.

The Ping depth limit control enables you to specify a depth limit that your sonar will search down to. It is recommended that limit is set to a depth of approximately 25% to 50% deeper than the maximum water depth you want to use your Fishfinder in. E.g.: In 200 ft max depth water the ping depth limit should be set between 250 ft and 300 ft.

RealVision™ 3D AHRS calibration

RealVision™ 3D transducers include a built-in AHRS (Attitude and Heading Reference Sensor), which measures the motion of your vessel to assist in the rendering of sonar images. After installation all RealVision™ 3D transducers require calibration.

An uncalibrated transducer can produce an offset to the front edge of the render of the bottom in the sonar image, as illustrated below.

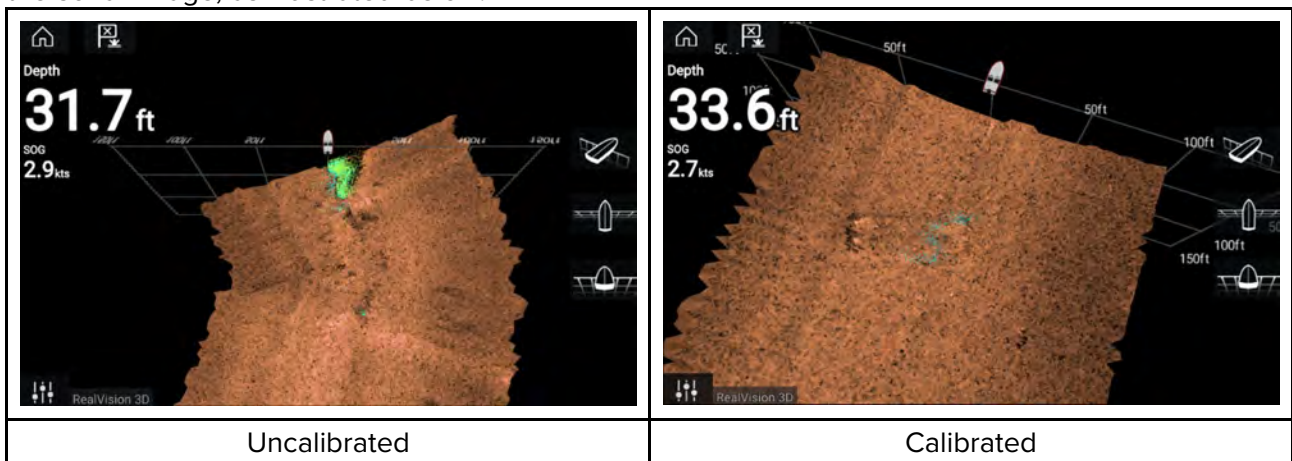

Calibration is an automatic process and starts after your vessel has turned approximately 100° at a speed of between 3 –15 knots. Calibration requires no user input, however at least a 270° turn is required before the calibration process can determine the local deviation and apply a relevant offset.

The time it takes to complete the calibration process will vary according to the characteristics of the vessel, the installation environment of the transducer, and the levels of magnetic interference at the time of conducting the process. Sources of significant magnetic interference may increase the time required to complete the calibration process. Certain areas with substantial magnetic deviation may require extra circles or “figure of 8” manoeuvres to be performed. Examples of such sources of magnetic interference include:

- Vessel engines
- Vessel alternators
- Marine pontoons
- Metal-hulled vessels
- Underwater cables

Note:

In some circumstances, it is beneficial to disable Realvision AHRS if local sources of magnetic interference are distorting the sonar image. Realvision AHRS can be disabled from **Settings**.

Menu > Settings > Sounder > AHRS stabilization

Note:

The Calibration process will require repeating after a **Sonar reset** or MFD **Factory reset**.

Transducer calibration (iTC-5)

You can calibrate transducers connected to your Lighthouse MFD via an iTC-5 Instrument Transducer Converter.

Note:

Transducer calibration requirements:

- An iTC-5 Instrument Transducer Converter.
- An MFD designated as the Data master.
- LightHouse software version 3.11 or later.

Note:

You can only calibrate transducers that are directly connected to the iTC-5 instrument you select for calibration. In systems with more than 1 iTC-5, it is important to remember which transducer(s) are connected to each iTC-5 instrument.

Network

To calibrate transducers, find the relevant iTC-5 unit from the list of devices connected to your MFD's network.

1. Open **Network**

Homescreen > Settings > Network

2. Find and select the iTC-5 unit.

3. Select **Calibrate**.

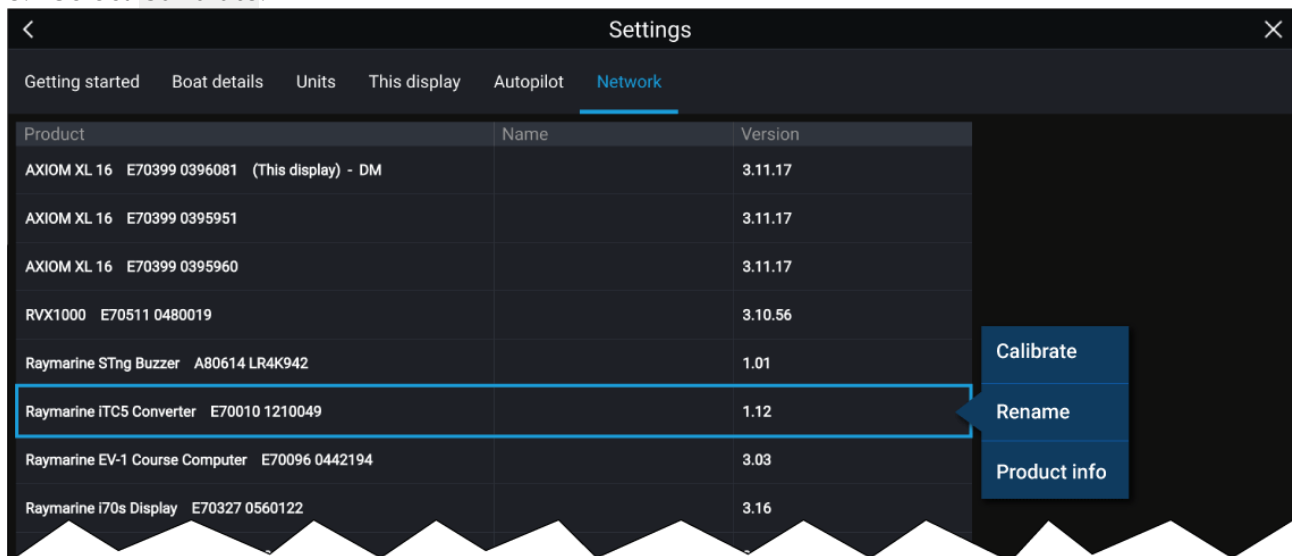

Data selection

You can choose which data type you want to calibrate:

- Depth
- Wind
- Speed

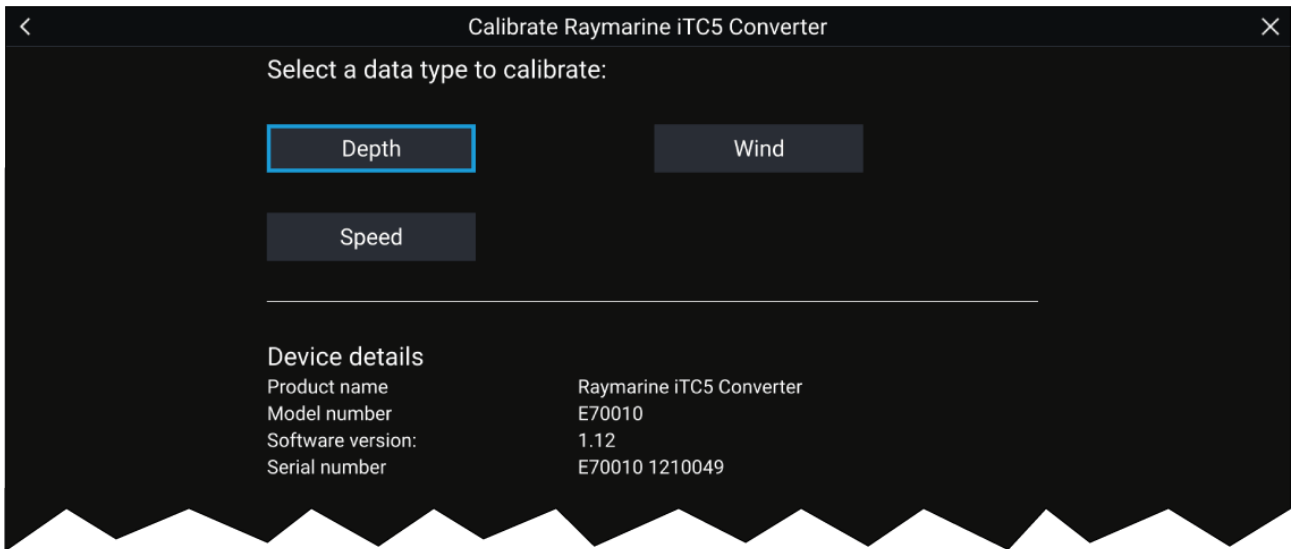



Depth

Calibrate your depth transducer.

Below keel	Enter the distance between the transducer face and the bottom of the keel.
Below waterline	Enter the distance between the bottom of your keel and the waterline.
Below transducer	No offset required.

Wind

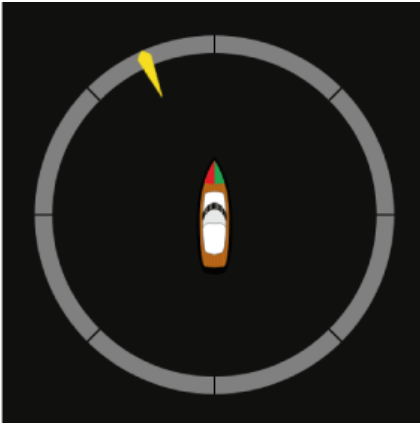
Calibrate your wind transducer.

<p>Linearise transducer</p> 	<p>Turn your boat in a circle until all sectors have been calibrated (the ring turns green).</p>
<p>Align wind transducer</p> 	<p>Head your boat directly into observed wind to align.</p>

Angle adjustment	Apply an offset to the angle.
Speed adjustment	Apply a scaling factor to apparent wind speed.

Speed

Calibrate your speed transducer.

Note:	For best results, ensure that there is minimal or no tide/current effect when calibrating speed through water.
--------------	--

Set STW to SOG	Apply a scaling factor to all STW readings, based on the present difference between STW and SOG.
Adjust STW	Apply a scaling factor to all speed through water values.

Assigning a function to the User Programmable Button (UPB)

You can assign a function to the User Programmable Button on an Axiom™ Pro MFD.

1. Press and hold the **User Programmable Button** on the MFD.
2. Select the required function from the list.

You can also assign a function to the **User Programmable Button** from the Settings menu: **Homescreen > Settings > This Display > User Configurable Key**.

Performing a settings or factory reset

Performing a **Factory reset** will erase ALL user data and reset the display's settings to their Factory default values. Performing a **Settings reset** will restore your display's settings to factory defaults, whilst retaining user data.

1. Select **Settings reset**, from the **This display** menu: **Homescreen > Settings > This display > Settings reset** to perform a settings reset.
2. Select **Factory reset**, from the **This display** menu: **Homescreen > Settings > This display > Factory reset** to perform a factory reset.

Importing user data

You can import user data (i.e.: Waypoints, Routes and Tracks) to your MFD.

1. Insert the MicroSD card that contains your user data files into a card reader slot on your MFD or connected card reader.
2. Select **Import from card** from the Import/export page: (**Homescreen > My data > Import/export > Import from card**).
3. Select the relevant SD card slot from the file browser and then navigate to your User data file (.gpx).
4. Select the relevant GPX file.
Your user data has now been imported.
5. Select **OK**.

4.6 Shortcuts

The Shortcuts menu can be accessed by swiping left to right across the **Power** button swipe area on an Axiom™ or Axiom™ XL MFD, or by pressing the **Power** button on an Axiom™ Pro , eS Series or gS Series MFD.

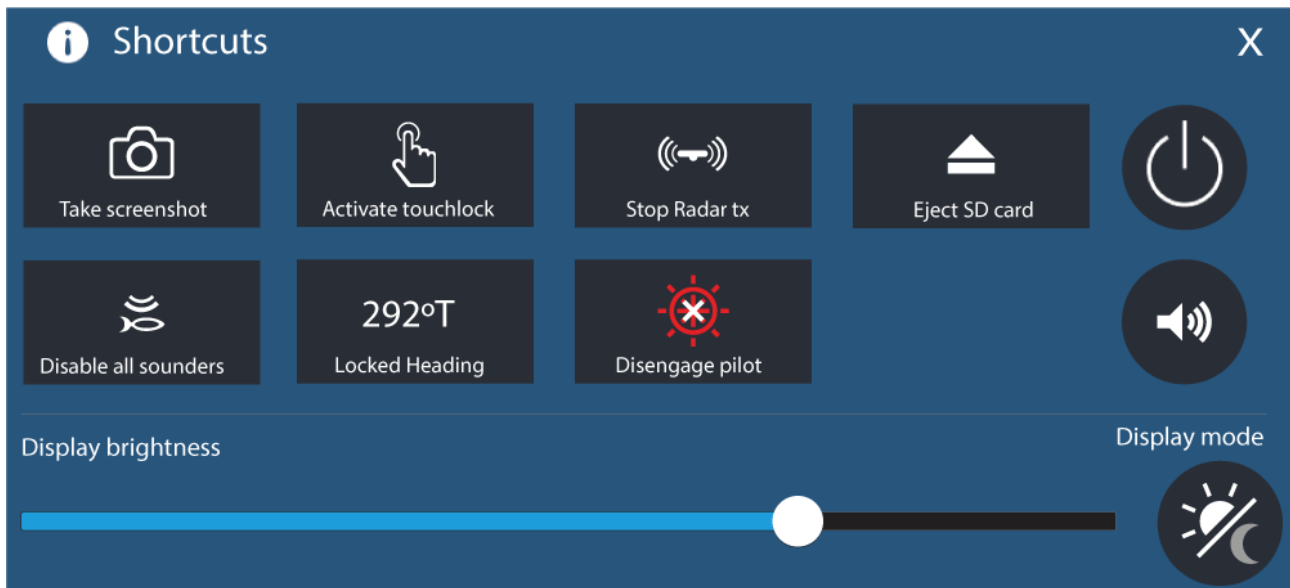

The following shortcuts are available:

- Take Screenshot
- Activate Touchlock
- Stop Radar transmitting
- Eject SD card
- Disable all Sounders
- Adjust Locked heading
- Engage / Disengage autopilot
- Power off
- Adjust Bluetooth speaker volume
- Adjust Brightness
- Display mode

Taking a screenshot

You can take a screenshot and save the image to external memory.

1. Swipe your finger from left to right across the **Power** button swipe area (applies only to Axiom™ or Axiom™ XL MFDs). Alternatively, press the **Power** button momentarily. The Shortcuts menu is displayed.

2. Select **Take screenshot**.

The screenshot will be saved in .png format to the **Screenshot file** location. The Screenshot file location can be selected from the **This Display** tab located in the **Settings** menu: **Homescreen > Settings > This Display > Screenshot file:**.

Note:

Due to protected content restrictions you cannot take a screenshot when the video input on an Axiom™ Pro or the Video 2 or HDMI input on an Axiom™ XL MFD is displayed onscreen.

Activating touchlock

In rough weather conditions precipitation may lead to erroneous touches being detected by the touchscreen. In these conditions you can use touchlock to prevent this.

1. Select **Activate touchlock** from the **Shortcuts** menu.

With touchlock activated the touchscreen will be disabled. To re-enable the touchscreen, swipe from left to right across the **Power** button swipe area.

Radar standby

You can place a transmitting Radar in Standby from the Shortcuts menu.

1. Select **Stop Radar tx** from the **Shortcuts** menu.

Eject SD card

Safely eject your SD card from your MFD.

1. Select **Eject SD card** from the **Shortcut** menu.
2. Select **Ok** from the **Info** menu to complete the process.

Disabling all sounders

In systems with multiple sonar modules, you can stop all sonar modules from pinging.

1. Select **Disable all sounders** from the shortcuts menu.

Autopilot shortcuts

When Autopilot control is enabled, the Shortcuts page provides an Autopilot icon which can be used to engage and disengage your autopilot. When the autopilot is engaged in Locked heading mode you can also adjust the locked heading from the Shortcuts page.

Bluetooth volume control

When your MFD is connected to a Bluetooth speaker, controls will be available to adjust speaker volume.

Homescreen



From the Homescreen select the Status area and then select the Speaker symbol to display the Bluetooth volume control for LightHouse™ app and MFD alarms.

Shortcuts page

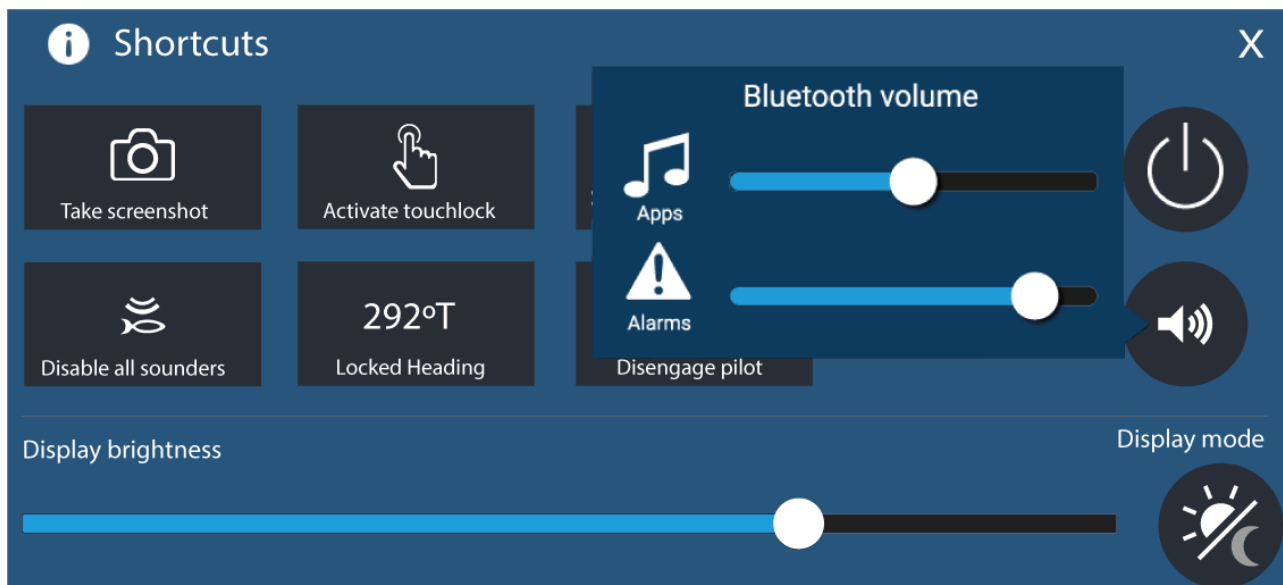

Press or swipe the **Power** button to display the Shortcuts page and then select the speaker symbol to display the Bluetooth volume control for LightHouse™ apps and MFD alarms.

Adjusting brightness

LCD brightness can be adjusted from the Shortcuts page.

With the Shortcuts page displayed (accessible via the Power button):

1. Move the **Display brightness** control along the slider bar to adjust the brightness.

*With the Shortcuts menu displayed you can also use the **Power** button or the **Power** button swipe area to increase the brightness level in increments, by repeating the left to right swipe. Please note, the swipe area is only available on Axiom™ or Axiom™ XL displays.*

Display mode

You can change your MFD's display mode.

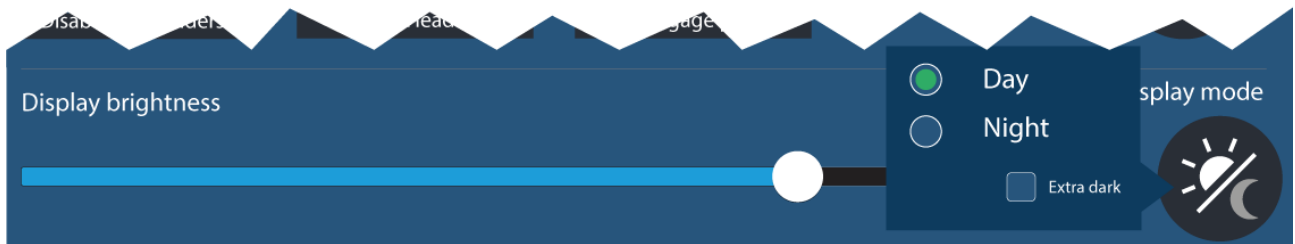

Press or swipe the **Power** button to display Shortcuts and then select the **Display mode** symbol to switch between **Day**, **Night**, and **Extra dark** display modes.

You can adjust the **Display mode** to suit the time of day:

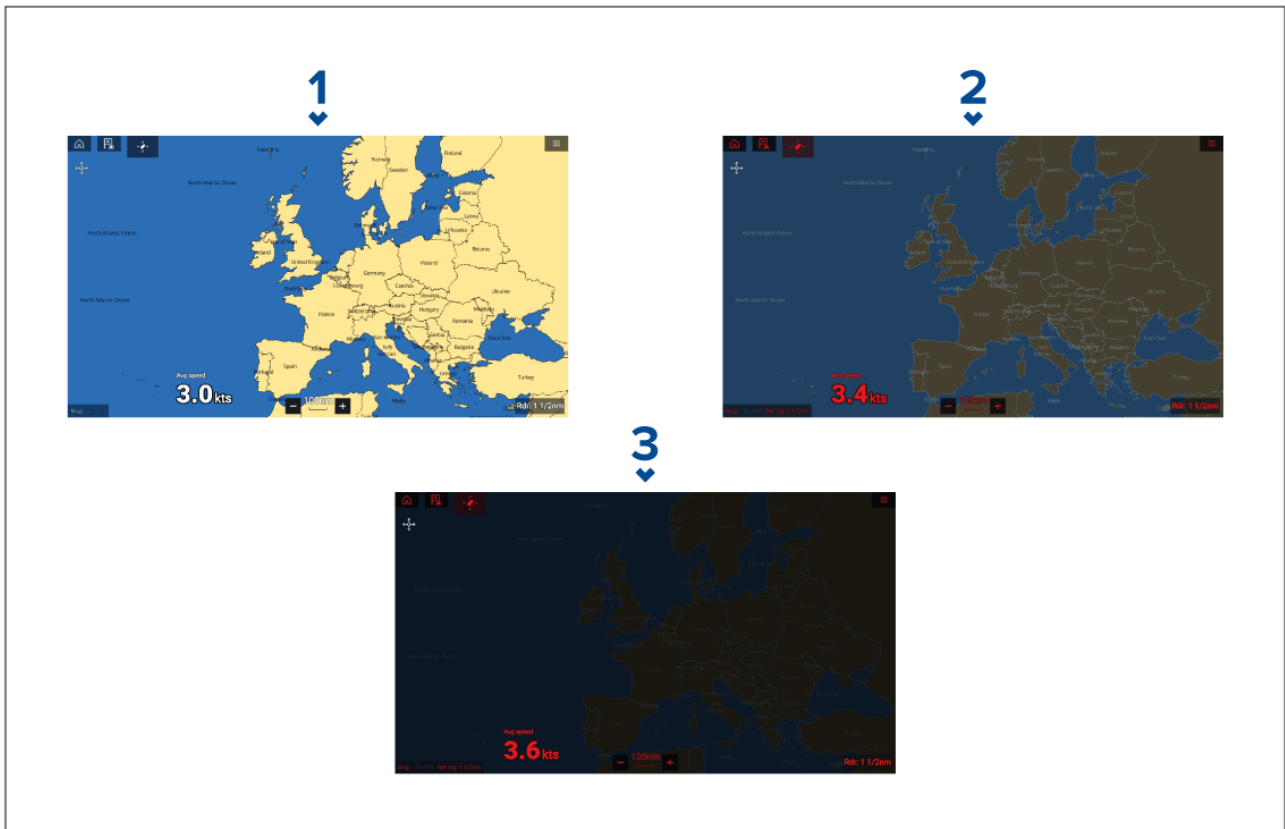

1. **Day** — White user interface and a light background.
2. **Night** — Red user interface and a dark background.
3. **Extra dark** — Red user interface and a very dark background.

Note: Night mode must be active before **Extra dark** can be selected.

4.7 Memory card compatibility

MicroSD memory cards can be used to backup / archive data (e.g. Waypoints, Routes and Tracks). Once data is backed up to a memory card, old data can be deleted from the system. The archived data can be retrieved at any time. It is recommended that your data is backed up to a memory card on a regular basis.

Compatible cards

The following types of MicroSD cards are compatible with your MFD:

Type	Size	Native card format	MFD supported Format
MicroSDSC (Micro Secure Digital Standard Capacity)	Up to 4GB	FAT12, FAT16 or FAT16B	NTFS, FAT32, exFAT
MicroSDHC (Micro Secure Digital High Capacity)	4GB to 32GB	FAT32	NTFS, FAT32, exFAT
MicroSDXC (Micro Secure Digital eXtended Capacity)	32GB to 2TB	exFAT	NTFS, FAT32, exFAT

- **Speed class rating** — For best performance it is recommended that you use Class 10 or UHS (Ultra High Speed) class memory cards, or better.
- **Use branded memory cards** — When archiving data it is recommended that you use good quality branded memory cards.

Caution: Care of chart and memory cards

To avoid irreparable damage to and / or loss of data from chart and memory cards:

- Ensure that chart and memory cards are fitted the correct way around. DO NOT try to force a card into position.
- DO NOT use a metallic instrument such as a screwdriver or pliers to insert or remove a chart or memory card.
- Ensure correct memory card ejection procedure is carried out before removing the chart or memory card from the card reader.

Removing MicroSD card from its adaptor

MicroSD memory and cartography chart cards are usually supplied inserted into an SD card adaptor. The card will need to be removed from the adaptor before inserting into your display.

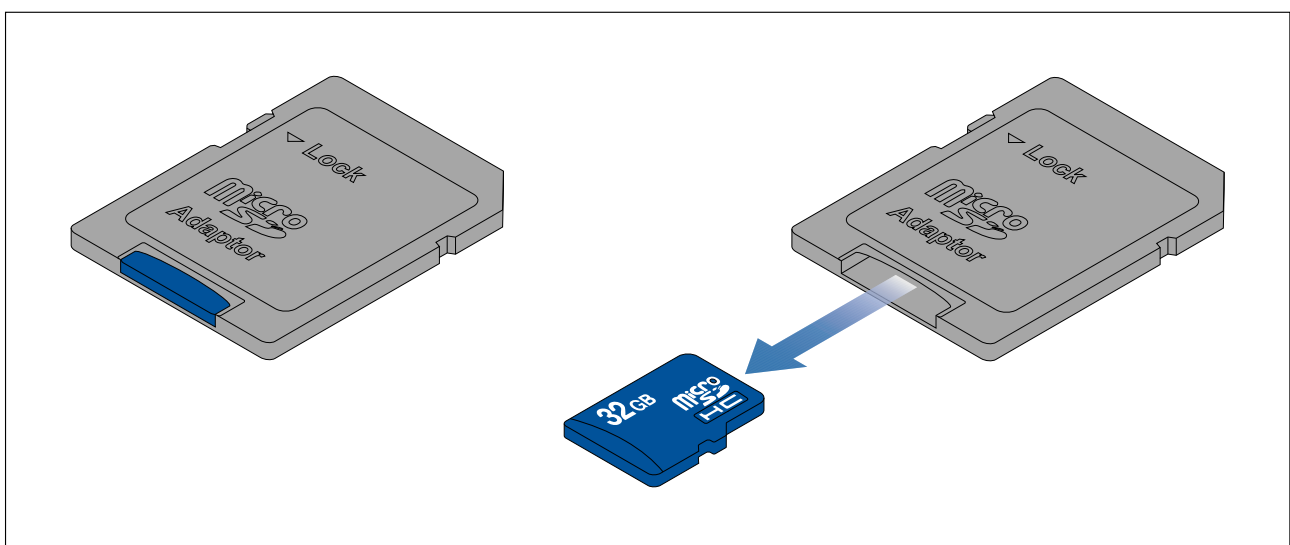

Inserting a MicroSD card — Axiom variants

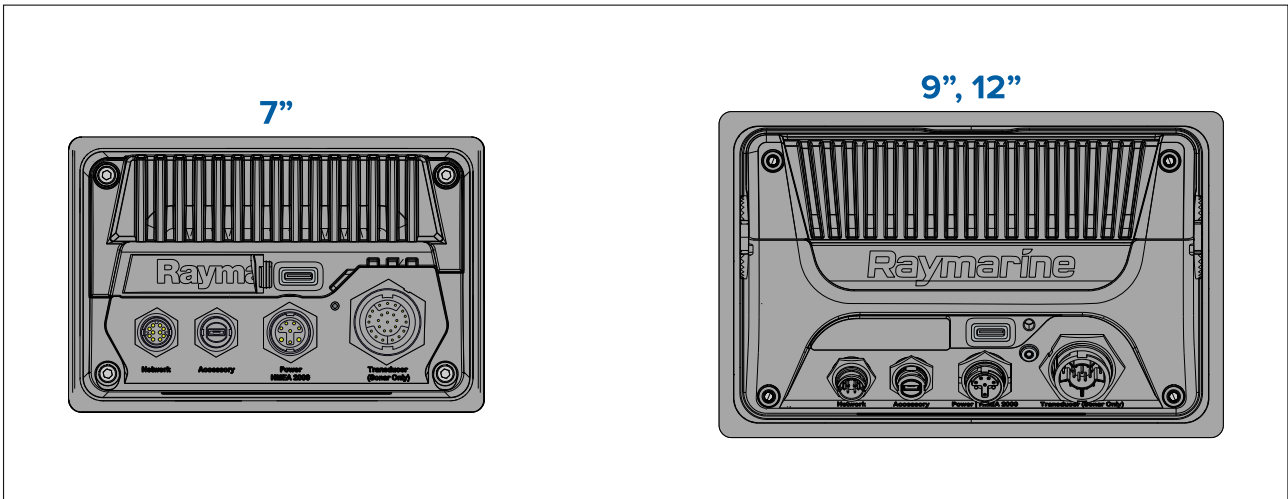

1. Pull back the microSD card reader cover as shown above.
2. Insert your microSD card with the contacts facing down.
3. Close the cover and ensure it is seated correctly.

Removing a MicroSD card

1. Select **Eject SD card** from the **Import/export** page: **Homescreen > My data > Import/export > Eject SD card**.
2. Remove the MicroSD card from the Rear of the MFD.
3. Ensure you close the card reader's cover.

Inserting a MicroSD card — Axiom Pro variants

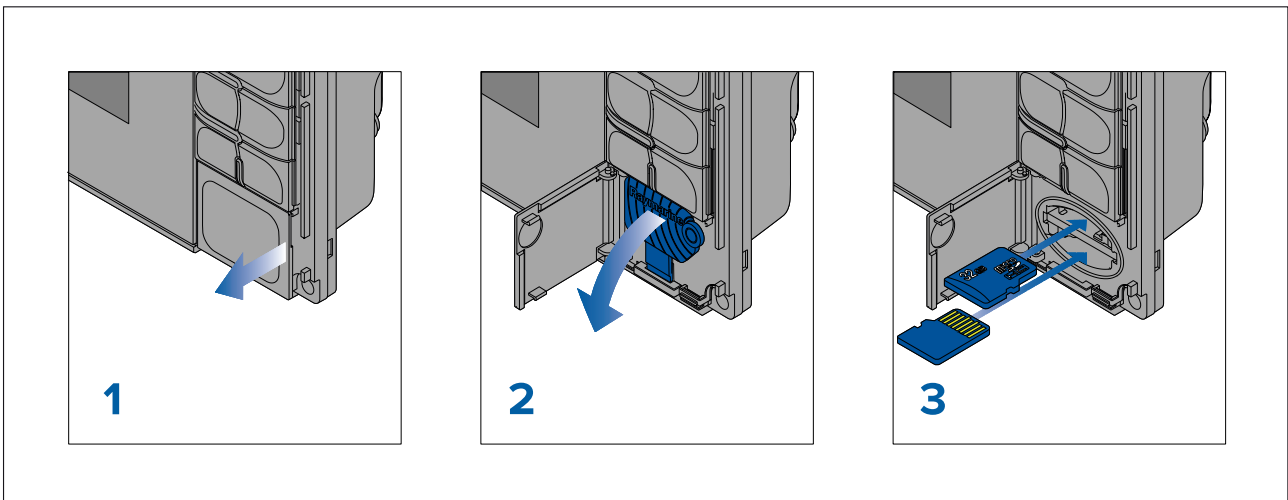

1. Open the card reader door.
2. Pull down the card reader cover.
3. Insert the card into a card slot and push until it clicks into place.

Note: When inserting a card into the lower card slot the memory card must be orientated with the contacts pointing upwards.

Removing a MicroSD card - Axiom Pro

With the card reader door open and cover pulled down:

1. Push the card in until it clicks.
2. Pull the card free from the card slot.

Inserting external storage devices - RCR

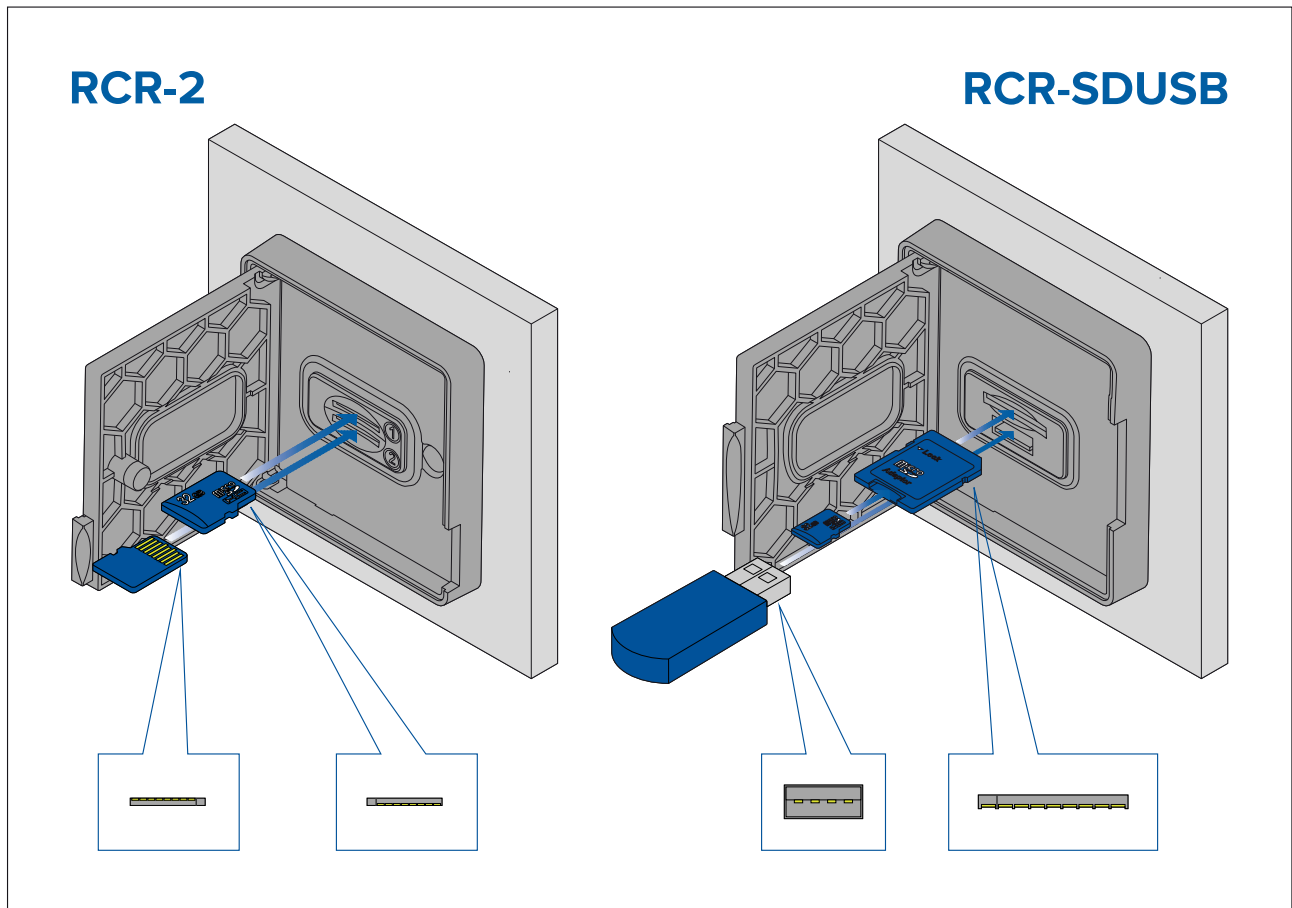

1. Open the card reader door.
2. Insert the storage device into a card slot and push until it clicks into place.
 - RCR-SDUSB slot 1 — With the contacts facing down, insert an SD card (or an SD card adaptor containing a MicroSD card) into the upper slot, labelled (1), and push until it clicks into place.
 - RCR-SDUSB slot 2 — With the contacts facing down, insert a USB drive directly into the lower slot, labelled (2).
 - RCR-2 slot 1 — With the contacts facing down, insert a MicroSD card into the upper slot and push until it clicks into place.
 - RCR-2 slot 2 — With the contacts facing up, insert a MicroSD card into the lower slot and push until it clicks into place.

Removing external storage (SD and MicroSD)

With the card reader door open:

1. Push the card in until it clicks.
2. Pull the card free from the card slot.

Removing external storage USB drive

With the card reader door open and cover pulled down:

1. Pull the drive free from the card slot.

Caution: Ensure card reader cover or door is securely closed

To prevent water ingress and consequent damage to the product, ensure that the card reader door or cover is firmly closed.

4.8 Software updates

Raymarine® regularly issues software updates for its products which provide new and enhanced features and improved performance and usability. It's important to ensure that you have the latest software for your products by regularly checking the Raymarine® website for new software releases.

www.raymarine.com/software

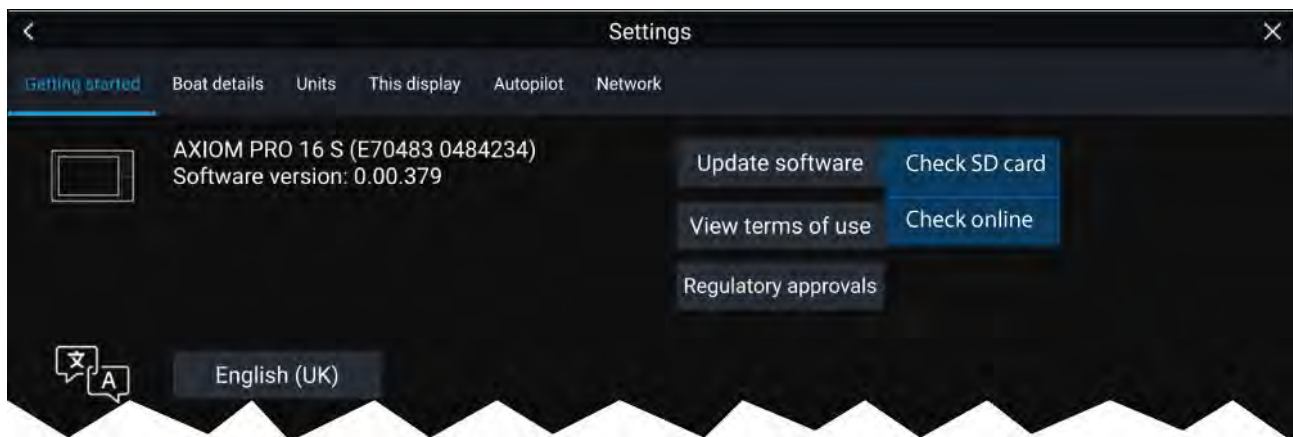

Note:

- It is recommended that you always backup your User data before performing a software update.
- To update compatible SeaTalkng® products you must use the designated Datamaster MFD that is physically connected to the SeaTalkng® backbone.
- In order to perform a software update any connected autopilot or Radar must be switched to Standby.
- The MFD's "Check online" feature is only available when the MFD has an Internet connection.
- To check which products are compatible with the MFD software update process, please refer to the website: www.raymarine.com/software.

Updating software using a memory card

Compatible SeaTalkhs® and SeaTalkng® products can be updated by following the steps below.

1. Check the software version of your product.

Refer to the documentation supplied with your product for information on checking software version.

2. Check the latest available software on the Raymarine website: (**www.raymarine.com > Support > Software Updates**).
3. Download the software package.
4. Copy the files to MicroSD card.
5. With your MFD powered on, insert the MicroSD card into the card reader slot.
Your MFD will automatically detect software files.
6. Follow the onscreen instructions to update your product software.
7. Alternatively you can select **Check SD card** from the **Update software** pop-over options on the Getting started tab: (**Homescreen > Settings > Getting started > Update Software**).

Updating software via the internet

Compatible SeaTalkhs® and SeaTalkng® products can be updated by following the steps below.

1. Select **Update software** from the Getting started tab: (**Homescreen > Settings > Getting started**).
2. Select **Check online** from the pop-over menu.
3. To set up a Wi-Fi connection select **Wi-Fi settings** and connect to the required Wi-Fi access point/hotspot.
4. Select **Start** and then follow any onscreen instructions.

4.9 Device pairing

Pairing a RMK remote keypad

You can control your MFD with an RMK keypad.

From the **This display** tab of the **Settings** menu: **Homescreen > Settings > This display** .

1. Select **Pair keypad**.
2. Follow the onscreen instructions to pair your keypad.

Ensure you select the correct orientation for the keypad during the pairing process.

3. Repeat steps 1 and 2 on each MFD you want to control from your keypad.

Note:

Please refer to the controls section of your keypad's documentation for details on controlling MFDs using a keypad.

Clear pairing (RMK)

1. Select **Clear pairings** to unpair ALL RMK keypads currently paired with the MFD.

Pairing with a Quantum Radar scanner

You can connect a Quantum Radar scanner to your MFD using Wi-Fi.

Pre-requisites:

- Ensure you have connected your Quantum Radar scanner in accordance with the instructions provided with the Radar scanner.
- Ensure you know your Radar scanner's SSID and passcode.

1. Select **Pair with Quantum** from the **This display** tab: **Homescreen > Settings > This display > Pair with Quantum**.
2. Follow the onscreen instructions to pair with your Quantum Radar.

The pairing process may take several minutes to complete.

For more information on the Quantum Radar pairing process (including troubleshooting information), refer to the Quantum Radar Installation instructions documents.

Pairing a Bluetooth speaker

Before attempting to pair with a Bluetooth speaker, ensure that the speaker is switched on and discoverable.

With your MFD's Bluetooth enabled:

1. From the Bluetooth settings page, select the relevant device from the **Available devices** list.
2. If requested, confirm the bluetooth pairing code.

If pairing is successful the speaker will appear in the **Paired devices** list and display the **Connected** message.

Chapter 5: Homescreen

Chapter contents

- 5.1 Accepting the Limitations on Use on page 60
- 5.2 Homescreen overview on page 60
- 5.3 MFD Apps on page 61
- 5.4 Creating / Customizing an App page on page 63
- 5.5 User profiles on page 64
- 5.6 Status area on page 66
- 5.7 Global positioning on page 68
- 5.8 My data on page 72
- 5.9 Alarms on page 77
- 5.10 Man Overboard (MOB) on page 81
- 5.11 DSC VHF radio integration on page 82
- 5.12 Settings on page 83
- 5.13 Connecting to a wireless display on page 92

5.1 Accepting the Limitations on Use

After your MFD has powered up the Homescreen is displayed.

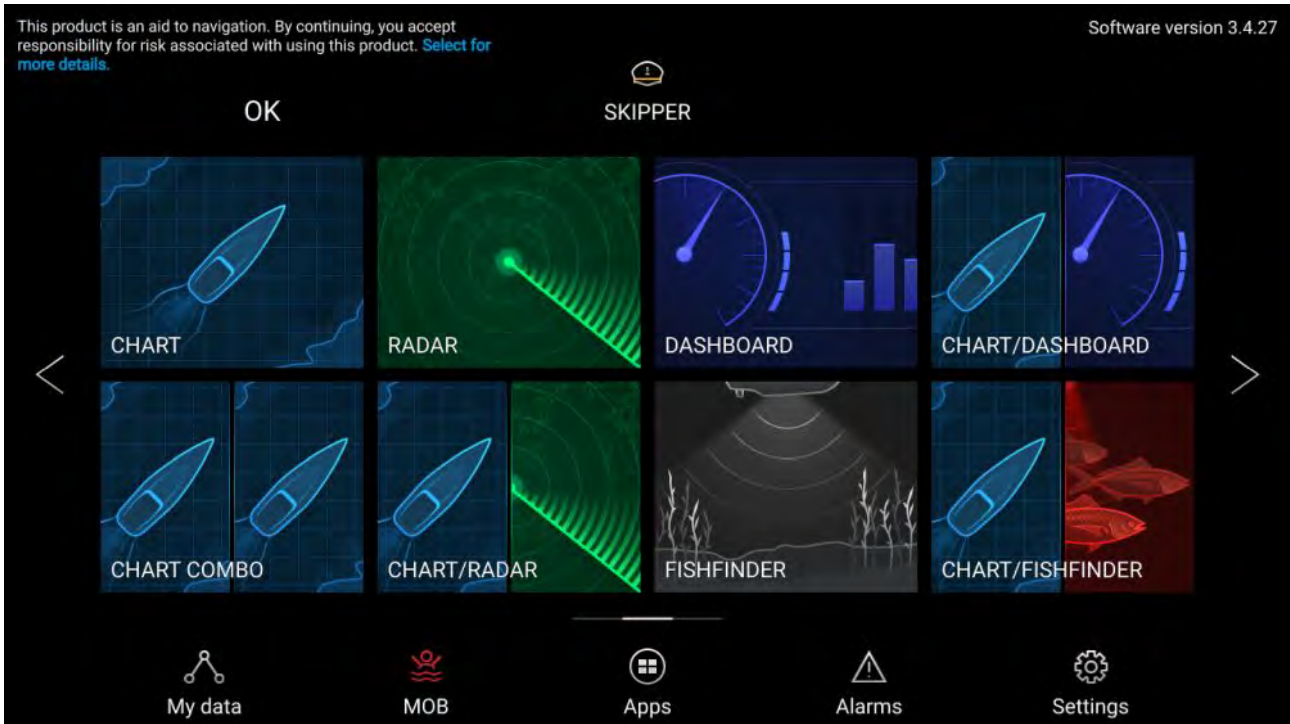

1. Before using the MFD you must accept the Limitations on Use (LoU) disclaimer. To view the full LoU Disclaimer, select 'more details'.

*The LoU acknowledgment is displayed each time the display is powered on and for each new user profile. The full LoU text can be accessed at any time from the **Getting started** tab: **Homescreen > Settings > Getting started > View terms of use.***

5.2 Homescreen overview

All settings and apps can be accessed from the Homescreen.

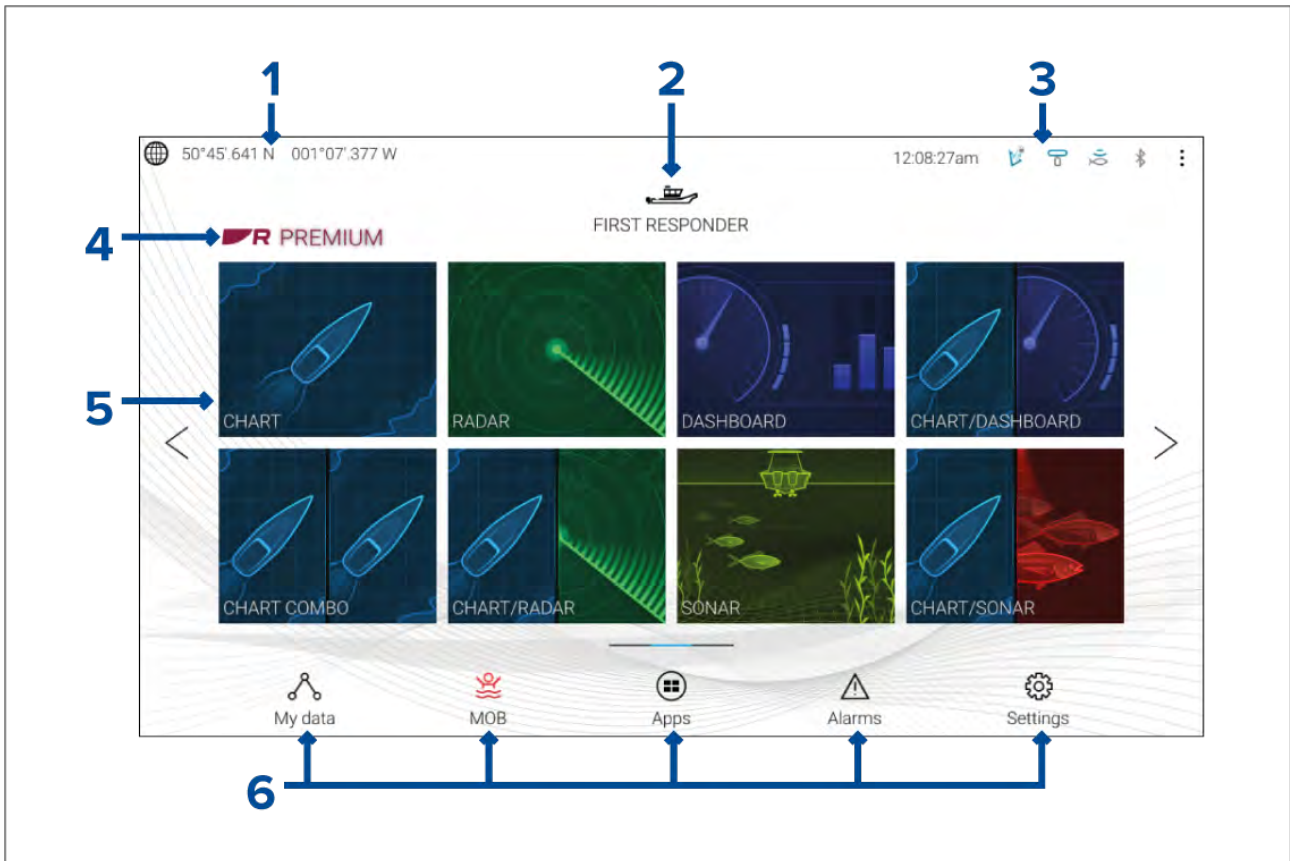







1. **GNSS position/fix details** — Select the area to view fix accuracy and access GNSS settings.
2. **Profile** — Select the area to change the profile in use or to create, edit or delete profiles.
3. **External devices and system time** — Select this area to access Bluetooth settings, Disengage your autopilot or adjust the UTC time offset.
4. **Premium logo** — The premium logo identifies that you have a LightHouse™ chart card inserted that has a valid Premium subscription to LightHouse™ charts. The logo is not displayed if the subscription has expired.
5. **App page icons** — Select an icon to open the relevant MFD app page. Use the **Left** and **Right** arrows , or swipe your finger left or right across the area to cycle through the available Homescreen pages.
6. **Settings and data** — This area provides access to the **Settings, Alarms, Apps** and **My data** menus. You can also activate the **Man Over Board (MOB)** alarm and disengage your autopilot.







Note:

When more than 1 display is connected to the same network, then the Homescreen of the MFD designated as Data Master will be mirrored on all MFDs.

5.3 MFD Apps

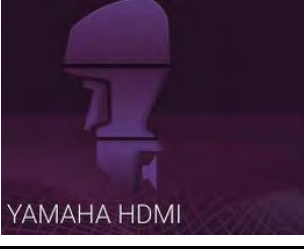
MFD apps are displayed on your MFD in App pages. Each app page is accessed from the app page icons on the Homescreen. App pages can include more than 1 app. The available MFD apps are:

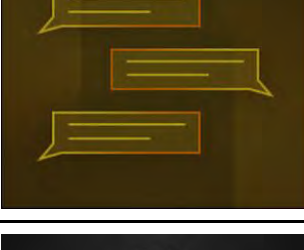
 <p>CHART</p>	<p>Chart — The Chart app displays electronic cartographic information from your Chart cards and when used in conjunction with a GNSS receiver, plots your vessel's position. The Chart app can be used to mark specific locations using Waypoints, build and navigate Routes or keep a record of where you have been by recording a Track. For more information refer to p.121 — Chart app</p>
 <p>RADAR</p>	<p>Radar — The Radar app is a situational awareness aid that displays a graphical representation of your surroundings in relation to your vessel using the echo/target returns from a connected Radar scanner. The Radar app allows you to track targets and measure distances and bearings. For more information refer to p.255 — Radar app</p>
 <p>FISHFINDER</p>	<p>Fishfinder — The Fishfinder app uses a connected sonar module and transducer to help you to find fish by building up an underwater view of bottom structure and targets in the water column covered by your transducer. For more information refer to p.241 — Fishfinder app</p>
 <p>AUDIO</p>	<p>Audio — The Audio app allows you to control audio from a connected compatible entertainment system. For more information refer to p.355 — Audio app</p>
 <p>DASHBOARD</p>	<p>Dashboard — The Dashboard app provides data readings from connected sensors and equipment. The Dashboard app is also used for controlling, configured, compatible, Digital Switching hardware. For more information refer to p.289 — Dashboard app</p>
 <p>VIDEO</p>	<p>Video — The Camera app allows you to control and view feeds coming from connected video equipment such as an IP camera or Thermal camera. For more information refer to p.321 — Video app</p>
 <p>UAV</p>	<p>UAV — The UAV (Unmanned Aerial Vehicle) app provides remote controls, settings and video display, including flight data for your compatible UAV device. For more information refer to p.373 — UAV (Unmanned Aerial Vehicle) app</p>

 <p>YAMAHA</p>	<p>Yamaha — The Yamaha app provides data readings from compatible Yamaha engines. For more information refer to p.303 — Yamaha app</p>
 <p>PDF VIEWER</p>	<p>PDF Viewer — The PDF Viewer app allows you to open PDF files located on your external storage. For more information refer to p.369 — PDF Viewer app</p>
 <p>YAMAHA HDMI</p>	<p>Yamaha HDMI — The Yamaha HDMI app provides data readings from connected Yamaha engines that use a compatible HDMI interface. For more information refer to p.303 — Yamaha app</p>
 <p>DOCKSENSE</p>	<p>DockSense — The DockSense app is used to control DockSense™ alert and DockSense™ Control systems.</p> <ul style="list-style-type: none"> • For DockSense™ Alert refer to separate operation instructions — document number 81393. • For DockSense™ Control refer to separate operation instructions — document number: 81398.
	<p>Messaging — The First responder boating activity profile includes a Messages app. For details refer to: p.222 — Messaging The Messages app also requires STEDS compatible AIS hardware.</p>
	<p>VesselView — The VesselView app provides data readings from compatible Mercury engines. For more information refer to p.317 — Mercury VesselView app</p>

Note:

- Not all apps may appear on the Homescreen by default, an app page can be created to view these apps.
- Some apps require connected hardware or specific MFD configurations for the apps to be available.

5.4 Creating / Customizing an App page

1. Press and hold on an existing App page icon to display pop-over options.

You can Customize, Rename or Delete app pages from the pop-over options.

2. Select **Customize** from the pop-over options to change page layout and apps used. To Create a new page press and hold on a blank space on the Homescreen.

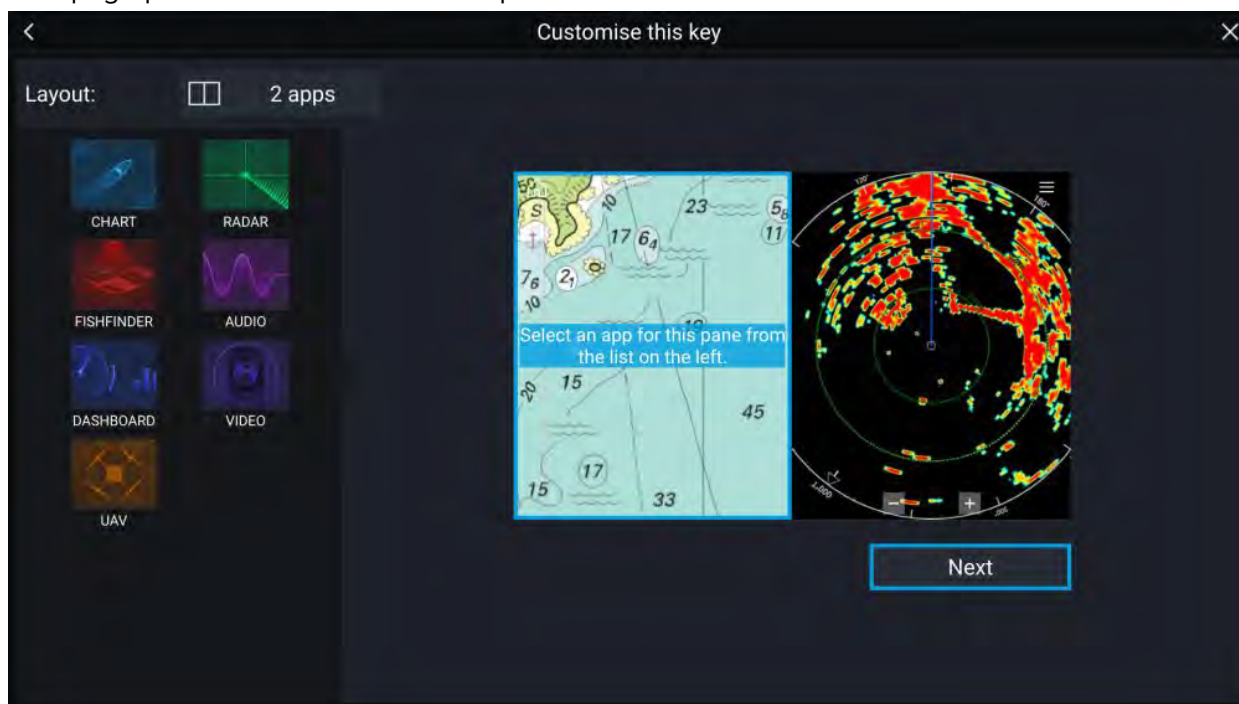

3. Select the **Layout:** option to change the page layout.
4. Select the icons for the Apps that you want to be displayed on the page.
5. Select **Next** and give the page a memorable name.
6. Select **Save**.

The page is saved and the new App page icon will be shown on the Homescreen.

5.5 User profiles

You can share your MFD with other users by creating user profiles on your MFD. Profiles enable you to retain your own personal settings whilst letting other users personalize the MFD's settings to their preference.

Note:

User data such as Waypoints, Routes, Tracks, images and video recordings etc. will be available to all users, and are shared by all users. This means that, for example, if you add or delete a waypoint while using one user profile, the change will also be reflected in all other profiles on the MFD, including demo profiles.

You can access the Profiles page by selecting the Profile Icon on the Homescreen.

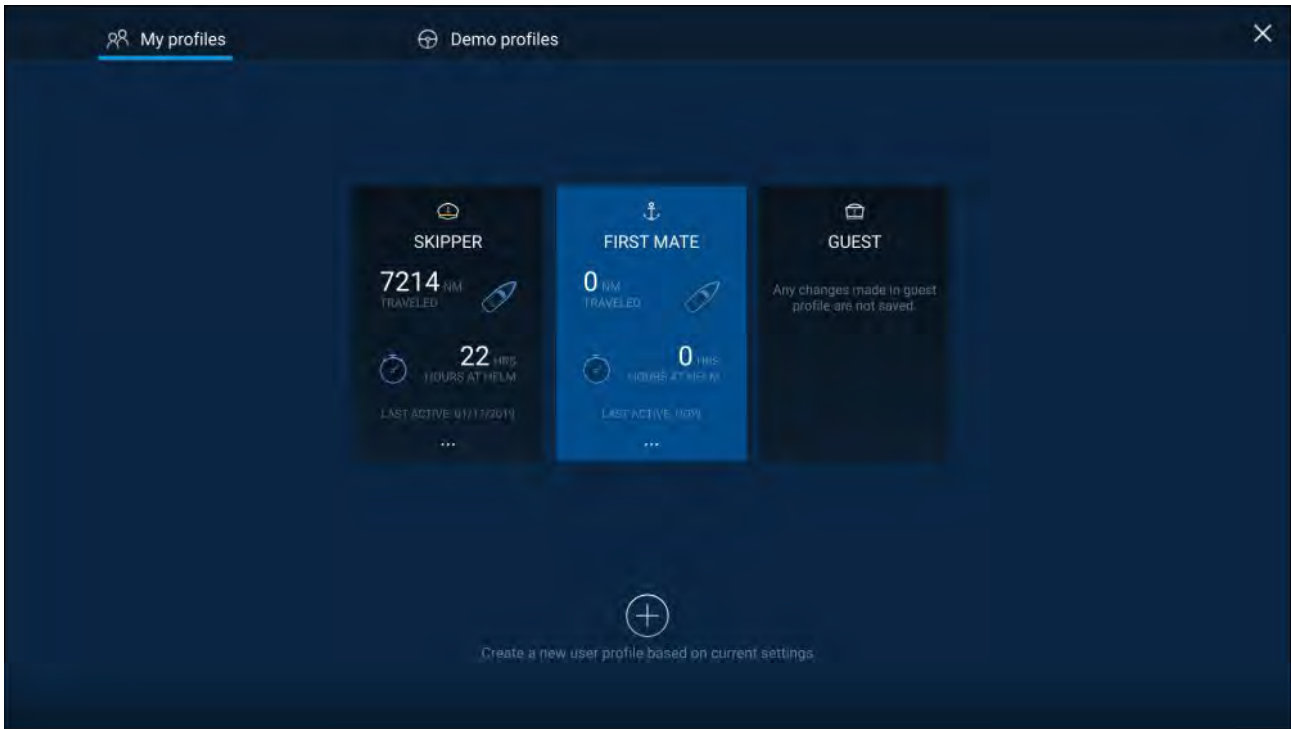

Selecting the **Plus (+)** icon will create a new profile based on the profile that is currently in use.

MFD settings changes are unique to the profile in use and are retained the next time the profile is used.

The distance and time that a profile has been active is displayed for each profile.

Profile names and icons can be customized. You can also reset the distance and time for each profile.

A Guest profile is available for temporary users. Setting changes to the Guest profile are not retained. Each time the Guest profile is activated the settings are based on the last used profile.

When the MFD is rebooted the last used profile will be active.

Demo profiles are also available to help you practice operating your MFD with simulated data.

Demo profiles

Profiles are available for simulation and demonstration purposes. A demo movie, stored on external storage, can also be set to play when a demo profile is activated and inactivity has been detected for 60 seconds.

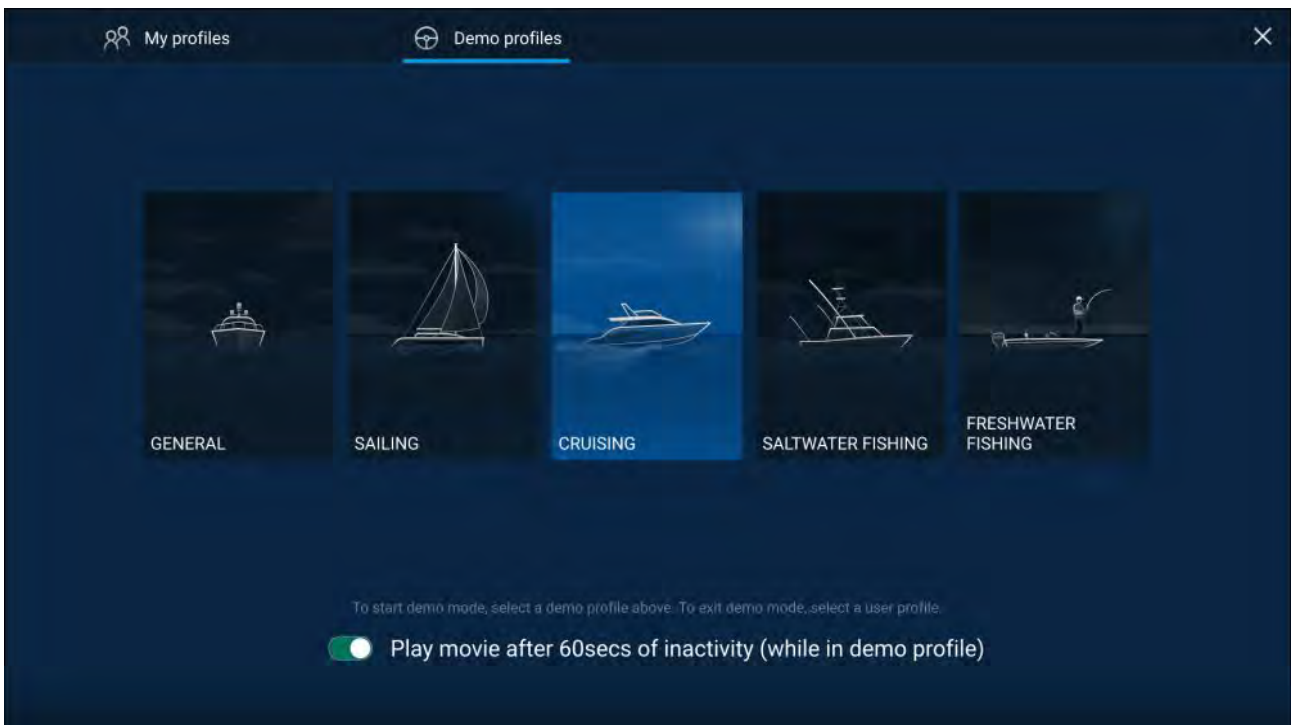

Selecting a Demo profile will provide your MFD with simulated data to help you practice operating your display.

Important:

- It is recommended that Demo profiles are NOT activated whilst navigating.
- User **data** such as Waypoints, Routes, and Tracks is shared with all the other user profiles on the MFD. This means that, for example, if you add or delete a waypoint while using a demo profile, the change will also be reflected in all other user profiles on the MFD.
- Demo profiles will NOT display any real data, including safety warnings and messages.
- Any **settings** changes made will not affect User profiles.

Demo movie requirements

A demo movie file can be set to play when a demo profile is active and the MFD has not been used for 60 seconds.

Demo movie files must be in the .mov file format and encoded using the H.264 video codec standard. The Demo movie files must be saved to an external storage device connected to the MFD. Demo movies are not shared across networked MFDs.

When the Demo movie feature is activated the system will search for a demo movie file associated with the active demo profile. If an associated file cannot be found then the generic demo.mov is played. See below for filename details.

Demo profile	Associated filename
General	demo_general.mov
Sailing	demo_sailing.mov
Cruising	demo_cruising.mov
Saltwater fishing	demo_salt.mov
Freshwater fishing	demo_fresh.mov
Plays in all demo profiles if an associated demo file is not found.	demo.mov

If an MFD is powered off with the demo movie active then the next time the MFD is powered on the demo movie will play immediately after boot up.

Any interaction with the Touchscreen or physical buttons will stop the movie playing and return you to the active demo profile.

5.6 Status area

You can view the status of connected peripheral devices using the MFD's Status area, located at the top right of the Homescreen. This area also displays the **Time** and identifies when the MFD is in **Touchlock** mode.

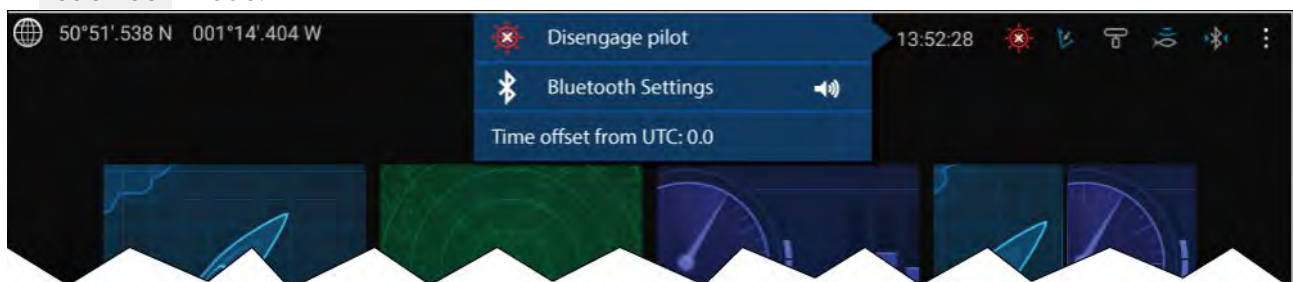

Status area icons

The status area provides icons which identify the status of connected Autopilot, AIS, Radar, Sonar/Transducer, and Bluetooth devices.

Pop-over menu options

From the **Options** pop-over you can:



- Disengage your autopilot.
- Access Bluetooth settings and volume controls.
- Adjust the Time offset from UTC.

Note:
 The First responder boating activity profile includes additional AIS mode, and SITREP options and provides Data logging status. For details refer to: [p.207 – First responder](#)

Status area icons

The icons displayed in the Status area signify the current status of certain connected devices.

AIS



Icon	Status	Icon	Status
	AIS transmitting and receiving		AIS receive only (e.g. Silent Mode)
	AIS Error		

Note:
 The First responder AIS boating activity profile includes an additional AIS icon. For details refer to: [p.207 – First responder](#)



Autopilot

Icon	Status	Icon	Status
	Autopilot engaged		



Bluetooth

Icon	Status	Icon	Status
	Bluetooth on / not connected		Bluetooth connected / paired

Radar

Icon	Status	Icon	Status
	Radar transmitting		Radar standby
	Radar error		

Sonar / Transducer

Icon	Status	Icon	Status
	Sonar pinging		Sonar not pinging
	Sonar error		

Touchlock

Icon	Status	Icon	Status
	Touchlock active		

Note:

The First responder boating activity profile also includes Data logging status icons. For details refer to: [p.207 – First responder](#)

5.7 Global positioning

Global Navigation Satellite System (GNSS) constellations

A GNSS constellation is a system of satellites that provides autonomous geospatial positioning that allows electronic devices with compatible receivers to determine their location (longitude, latitude and altitude).

Available GNSS constellations



1. **GPS** — (NAVSTAR) Global Positioning System is the US owned constellation of satellites that became fully operational in 1995. GPS is the most widely used GNSS constellation and the term GPS has become synonymous with GNSS.
2. **Galileo** — EU owned satellite constellation that became fully operational in 2019.
3. **BeiDou** — Chinese Regional Navigation Satellite System, currently in its third generation, became fully operational in 2020.
4. **GLONASS** — (*GLO*balnaya *NA*avigatsionnaya *Sputnikovaya Sistema*" or "Global Navigation Satellite System") is the Russian owned constellation of satellites that has offered global coverage since 2010.

Satellite based augmentation systems (SBAS)

Satellite based augmentation systems (SBAS) are systems that are used to compliment existing GNSS by providing differential corrections that improve a GNSS’s attributes such as accuracy, availability and reliability.

The image below shows approximate coverage of the SBASs available on the MFD:

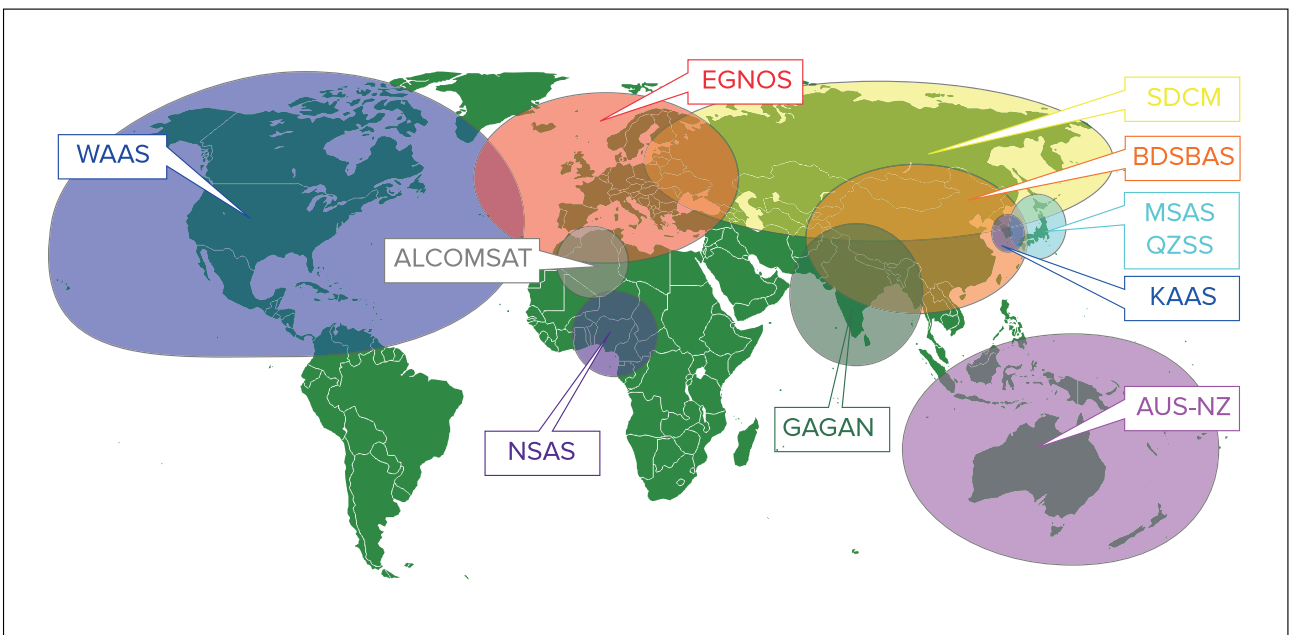

1. **ALCOMSAT** (Algeria)
2. **AUS-NZ** (Australia / New Zealand)
3. **BDSBAS** (China)

4. **EGNOS** (Europe)
5. **GAGAN** (India)
6. **KAAS** (Korea)
7. **MSAS** (Japan)
8. **NSAS** (Nigeria)
9. **SDCM** (Russia)
10. **WAAS** (USA)
11. **QZSS** (JAPAN)

GNSS (GPS) Status

Your vessel's GNSS (GPS) position is provided in the top left corner of the Homescreen. The status of the position fix and the satellites in use is displayed in the Fix menu.



1. If latitude and longitude is displayed on the Homescreen, you have a valid position fix. If the text turns red, your fix accuracy is low. To access the **Fix** menu select the Position details area on the Homescreen and then select **Satellites** from the Pop-over menu.
2. Select to access settings related to the GNSS (GPS) receiver.
3. The name of the GNSS (GPS) receiver currently being used to provide position data to the system is displayed centered at the top of the screen.
4. Position fix and fix accuracy data is displayed..
5. The shape of the satellite symbols identify which GNSS constellation they belong to.
6. The sky view on the left side of the page shows the position of navigation satellites. The color of the satellite identifies its status:
 - Green = satellite in use
 - Orange = tracking satellite (not currently used for position fix)
 - Gray = searching for satellites
7. The signal strength indicator for the satellites can be enabled and disabled using the **Show Signal (dB)** toggle switch.

GNSS (GPS) Settings

The settings for your GNSS (GPS) receiver (internal or external) can be accessed from the **Satellites** menu: **Homescreen > GNSS pop-over > Satellites > Settings**.

Settings displayed are for the GNSS (GPS) receiver currently in use. The name of the GNSS (GPS) receiver currently being used by the system is displayed in the **Fix** menu.

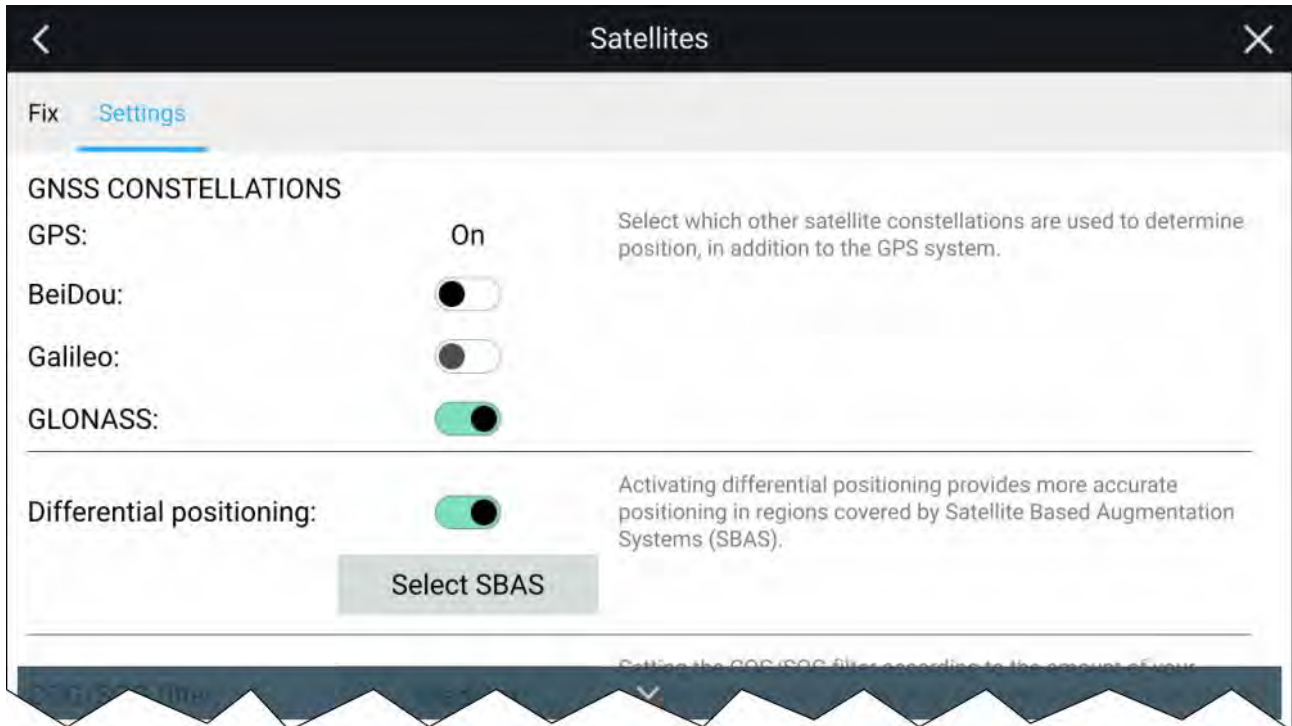

GNSS Constellations:

The GPS constellation (USA) is always enabled and cannot be disabled. One other GNSS can be enabled at the same time as GPS:

The GNSSs available are:

- BeiDou (China)
- Galileo (EU) — Not currently supported.
- GLONASS (Russia)

Differential positioning:

- Enable and disable the use of **Differential positioning** (SBAS) using the toggle switch. Enabling differential positioning provides more accurate positioning in regions covered by Satellite Based Augmentations Systems (SBAS).
- Select **Select SBAS** to view a list of supported SBASs used for differential positioning. The SBASs being used can be enabled and disabled using the relevant check boxes

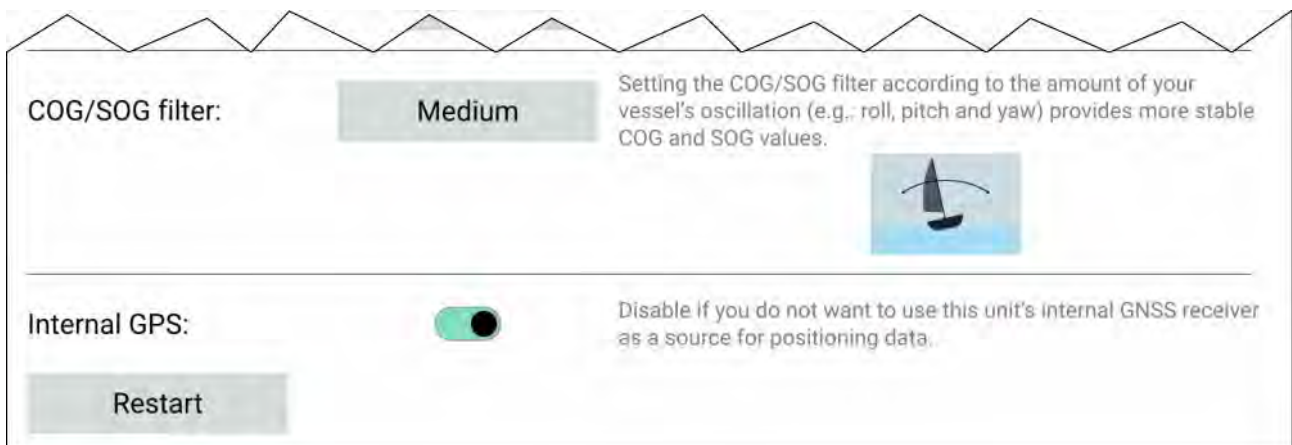

COG / SOG filter

Setting the COG / SOG filter according to the amount of your vessel's oscillation (e.g.: roll, pitch and yaw) provides more stable COG and SOG values.

The data reported by your GNSS receiver provides an instantaneous measure of the receiver's speed and direction. Under certain conditions the data can become erratic. (e.g.: a slow moving sailing vessel in rough seas will have a high oscillations and will benefit from a High setting, whereas a power boat that can quickly change speed and direction will have a low oscillation and will benefit from a low settings.)

The available options are:

- High
- Medium (default)
- Low

Note:

The filter does not affect your GNSS receiver's reported position.

Internal GPS

If applicable, you can enable and disable the MFD's internal receiver using the toggle switch.

Disable if you do not want to use the MFD's internal GNSS receiver as a source for positioning data.

For troubleshooting purposes you can also **Restart** the active GNSS receiver.

5.8 My data

Selecting **My data** from the Homescreen provides access to user data such as **Waypoints**, **Routes**, **Tracks**, **Fuel** and **Trip** data and also media **Files**. You can also **Import/export** User data and MFD settings.

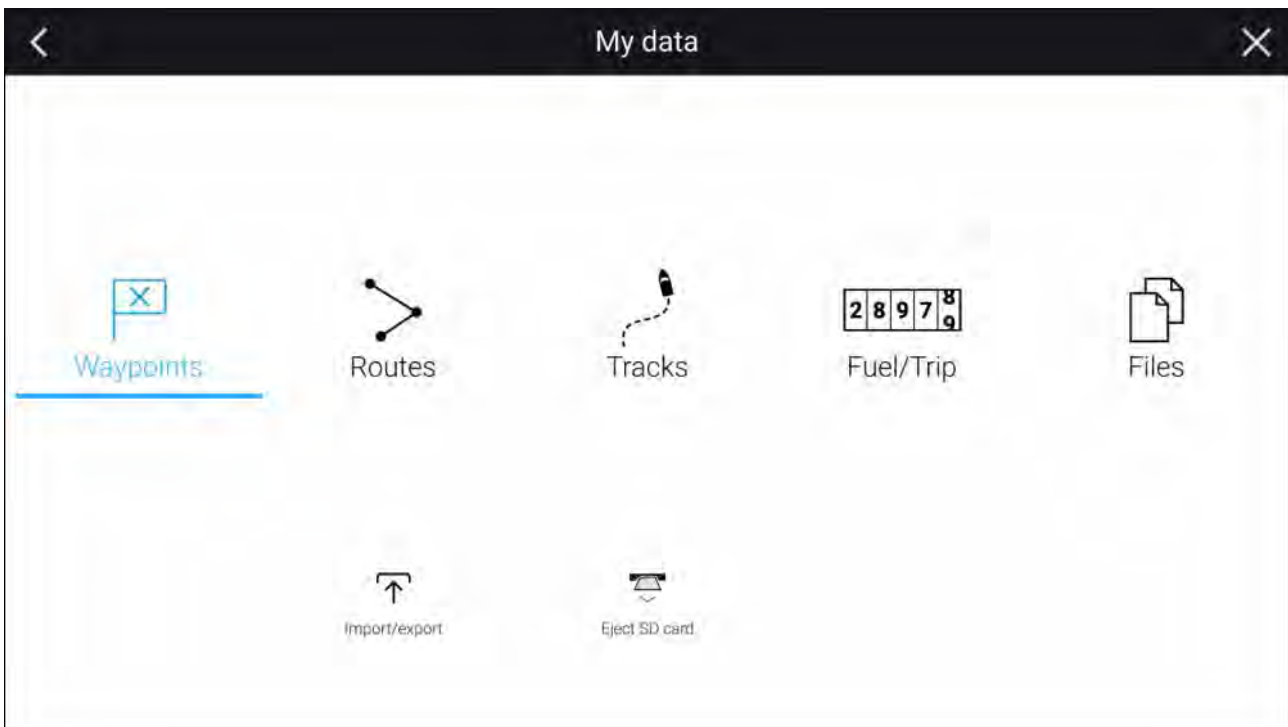

Selecting **Waypoints**, **Routes** or **Tracks** displays the relevant list, where you can manage and customize your data.

Selecting **Fuel/Trip** displays the Fuel manager and Trip counters.

Selecting **Files** opens a file browser.

Selecting **Import/export** allows you to backup or restore user data and MFD settings using an external storage device.

Note:

MFDs configured with the First responder boating activity profile include a Messages icon on the My data page which allows access to the Messages app. For details refer to: [p.222 – Messaging](#)

The Messages app also requires STEDS compatible AIS hardware.

Fuel/trip manager

The fuel/trip manager collects trip data automatically based on distance travelled and provides an estimate of how much fuel you have remaining based on user inputted fuel refill data.

The Fuel/trip manager can be accessed by selecting **Fuel/Trip** from the **My Data** page: **Homescreen > My Data > Fuel/Trip**.



1. Estimated fuel remaining
2. **Set all tanks full** — Select when you have filled up all tanks.
3. **Add partial fuel fill** — Select to enter a specific volume of fuel during a partial tank fill.

Note: If you enter the wrong amount of fuel this can be corrected by entering a minus value as a partial fuel fill, this will reduce the total amount of fuel remaining by the amount entered.

4. Trip (Manual) — accumulates data until reset.
5. Trip (Day) — resets automatically when local time passes midnight.
6. Trip (Month) — resets automatically on the 1st day of the month.
7. Trip (Season) — accumulates data until reset.
8. **Reset trip** — The **Trip (Manual)** and **Trip (Season)** logs can be reset by selecting the relevant **Reset Trip** button.

Note:

- The Fuel manager estimates the amount of fuel remaining onboard based on logging each time you fill up, your vessel's total fuel capacity, and how much fuel is burned by your engine(s). Incorrect entries will affect the fuel calculations which could result in a shortage of fuel.
- The Fuel remaining calculation is an estimate and will be inaccurate if fuel fills are not entered, entered incorrectly, or if fuel is used by other sources (e.g.: generators).
- Distance to Empty and Time to Empty values are based on estimated fuel remaining calculations which do not take into account the effects of weather and tide on fuel usage.
- This system is not a substitute for other fuel calculations. You should not rely on the Fuel manager calculations for accurate voyage planning or in emergency and safety critical situations.

Fuel set up

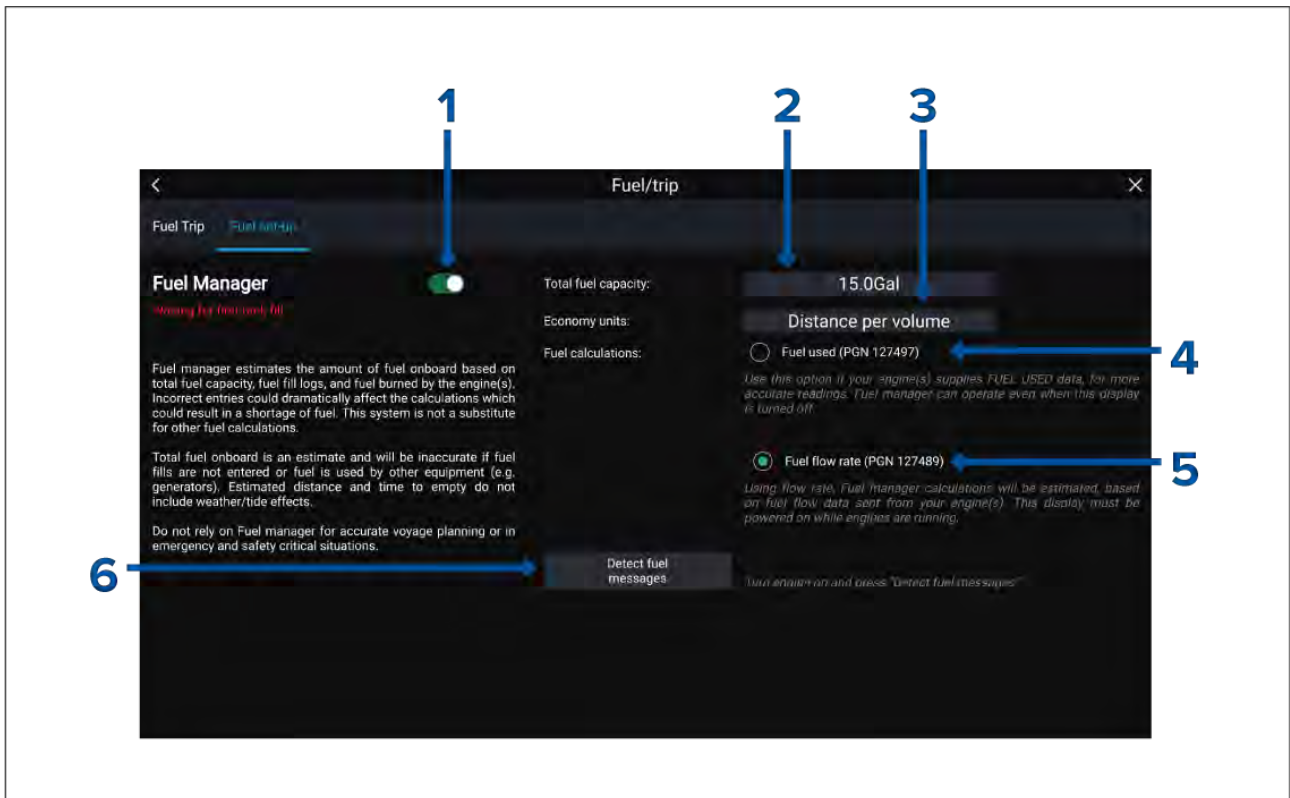

1. Enable/Disable Fuel manager.
2. **Total fuel capacity** — Sum of total capacity of all your fuel tanks.
3. **Economy units** — Economy units used in data overlays, Side bars or the Dashboard app.
4. **Fuel used (PGN 127497)** — Use this option if your engine(s) supply Fuel used data. When Fuel used is selected the Fuel manager will continue to operate when the MFD is switched off. This option usually provides more accurate readings.
5. **Fuel flow rate (PGN 127489)** — this option estimates fuel calculations based on fuel flow rate data sent by your engine(s). Your MFD must remain switched on, whilst engines are running.
6. **Detect fuel messages** — If you are unsure which engine messages your engine provides, select this option to determine the correct message.

Setting up the Fuel manager

To start using the Fuel manager you must first specify the total capacity of your fuel tanks, and then fill the tanks to set a reference level for the Fuel manager.

From the Fuel set-up page: **Homescreen > My Data > Fuel/Trip > Fuel set-up:**

1. Select the box next to **Total fuel capacity:** and enter the total capacity of all of your fuel tanks.
2. Select the **Fuel manager** toggle switch to enable the Fuel manager.
3. Select the box next to **Economy units:** and select either: Distance per volume, Volume per distance, or Litres per 100km.
4. Select either **Fuel used (PGN 127497)** or **Fuel flow rate (PGN 127489)**. If you are unsure, select **Detect fuel messages** to detect which messages are available to your MFD.
5. Fill up your fuel tanks.
6. Once the tanks are full, select **Set all tanks full** from the Fuel Trip page.
7. Log each subsequent fuel fill whether partial or full.

Files

The file browser can be used to **Open** and **Delete** photos / images and PDF documents, saved to external storage, and can also be used to **Import** or **Delete** user data and MFD settings files) saved to external storage.

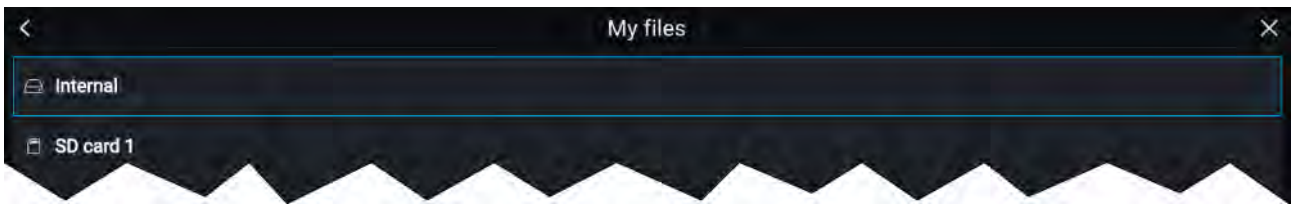

- Selecting a storage device expands its contents, allowing you to browse the contents.
- Selecting an image or PDF file provides pop-over options to open or delete the file.
- Selecting a user data (.gpx) or MFD settings (.lh3) file provides pop-over options to **Import** or **Delete** the file.

Note:

Only file types that are supported by your MFD will be visible in the browser.

View PDFs

PDF files can be viewed by opening them directly from the file browser or opening them using the PDF Viewer app. For more information on the PDF Viewer app refer to [Chapter 19 PDF Viewer app](#)

Import/export

User data and MFD settings can be imported and exported from your MFD. User data (Waypoint, Routes and Tracks) is saved in the common .gpx file format. MFD settings will be saved in .lh3 format.

The Import/export page can be accessed from the My data page: **Homescreen > My data > Import/export**.

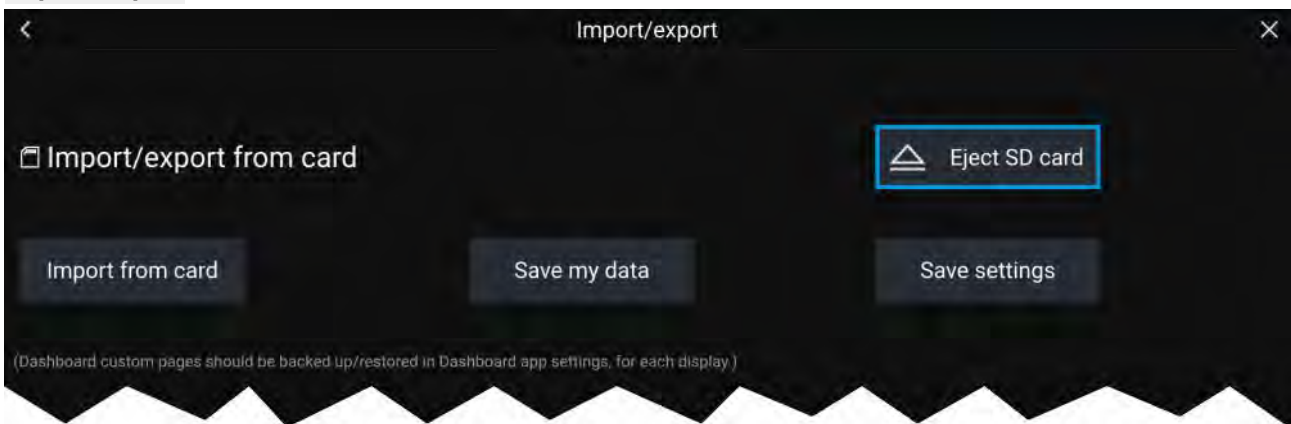

Saving user data (My data)

You can backup your user data (waypoints, routes and tracks) to a MicroSD card.

Note:

The LightHouse™ 3 operating system allows multiple waypoints to be created with the same waypoint name. If you intend to import the saved waypoints to a different system ensure that all waypoint names are unique or that the system you are importing them onto supports non-unique waypoint names.

Example: If more than 1 waypoint with the same waypoint name is imported into a LightHouse™ 2 MFD only 1 waypoint with that waypoint name will be imported as the LightHouse™ 2 operating system requires waypoint names to be unique.

1. Insert a memory card into your display's card reader.
2. Select **Save data to card** from the Import/export page: **Homescreen > My data > Import/export**. A pop-over menu is displayed.
3. Select the desired option:

- **Save all data** to save (export) all waypoints, routes and tracks.
 - **Save waypoints** to save (export) all waypoints.
 - **Save routes** to save (export) all routes.
 - **Save tracks** to save (export) all tracks.
4. Select **Save** to save the user data using the default filename. Alternatively:
 - i. Use the onscreen keyboard to enter your own filename and then select **Save**.
 5. Select **OK** to return to the Import/export page, or select **Eject card** to safely remove the memory card.

The user data file is saved to the ‘\Raymarine\My Data\’ directory of your memory card in gpx format.

Saving MFD settings

You can backup your MFD’s settings to an external storage device, allowing you to restore your personalized MFD settings at a later date.

Important:

- Saving your MFD settings will also save any new or customized dashboard pages.
- Digital switching dashboard pages will not be saved when saving your MFD’s settings.

1. Insert a memory card into a card reader slot on your MFD.
2. Select **Save settings** from the Import/export page: **Homescreen > My data > Import/export**.
3. Select the relevant card slot from the Info dialog.
4. Select **Save** to save the user data using the default filename. Alternatively:
 - i. Use the onscreen keyboard to enter your own filename and select **Save**.
5. Select **OK** to return to the Import/export page, or select **Eject card** to safely remove the memory card.

Importing user data or MFD settings from a memory card

You can restore user data (waypoints, routes and tracks) from an external storage device.

Important:

- Restoring your MFD settings will also restore any new or customized dashboard pages.
- Digital switching dashboard pages will not be restored when importing your MFD’s settings.

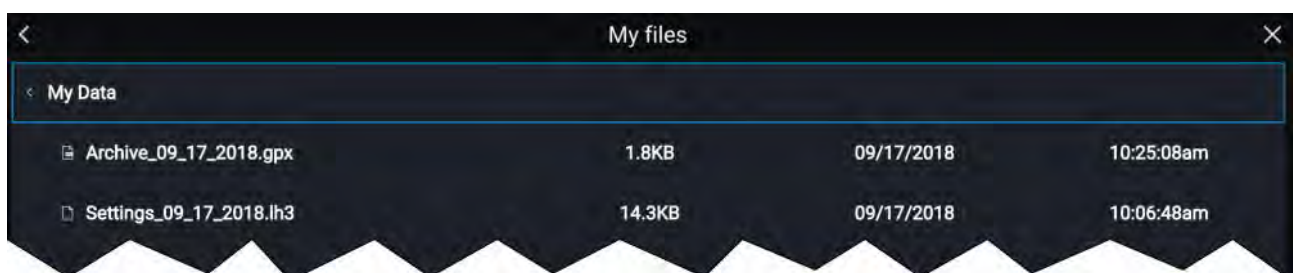

1. Insert the memory card containing your saved data into a card reader slot.
2. Select **Import from card** from the Import/export page: **Homescreen > My data > Import/export**.
The file browser is displayed
3. Navigate to the gpx or lh3 file that you want to import.

User data and MFD settings files will be located in the \Raymarine\My Data\ folder on your memory card.

4. Select the file.
The import will commence.
5. If importing a gpx file, select **OK** when complete, alternatively
6. If importing MFD settings, select **Yes** to confirm restoring your MFD’s settings.

Your MFD will reboot to complete the process.

5.9 Alarms

Alarms are used to alert you to a situation or hazard requiring your attention. Alarms are triggered by system functions and external devices connected to the MFD (Multifunction Displays). Alarms are displayed on all networked MFDs.

Alarms are color coded to signify their severity:

Dangerous alarms



Red — A Red notification is used to signify a dangerous alarm condition, immediate action is required due to a potential or immediate danger to life or vessel. Dangerous alarms are accompanied by an audible tone. The Dangerous alarm notification and audible tone will continue to be displayed until acknowledged or the conditions that triggered the alarm are no longer present. Acknowledged alarms may remain active whilst the alarm condition persists but will not trigger further onscreen or audible notifications.

Warning alarms

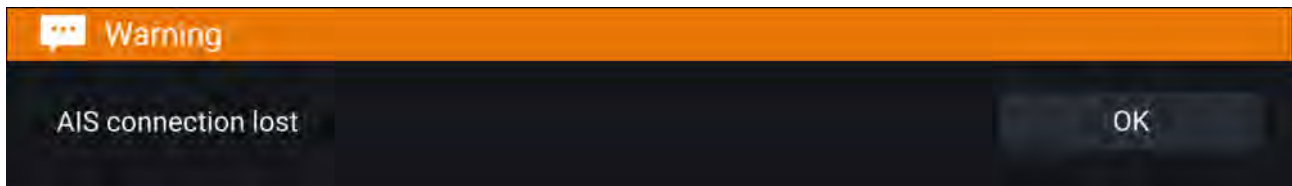

Orange — An Orange notification is used to signify a warning alarm condition. Warnings alarms are used to signify that there has been a change in situation that you need to be aware of. Warnings alarms are accompanied by an audible tone. The warning alarm notification and audible tone will continue to be displayed until acknowledged or the conditions that triggered the alarm are no longer present. Acknowledged alarms may remain active whilst the alarm condition persists but will not trigger further onscreen or audible notifications.

Notifications

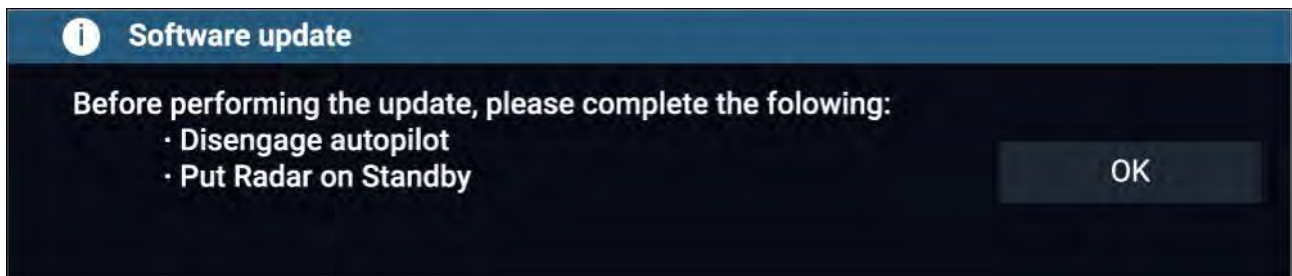

Blue — A Blue notification is used to signify information requiring user acknowledgement. Unless they require user interaction, information notifications may self dismiss after 3 seconds. Information notifications are not accompanied by an audible tone and are not displayed in the Active alarms or Alarm history lists.

Alarm manager

The Alarm manager is used to list current active alarms, enable and disable alarms, adjust alarm thresholds and view Alarm history.

Active alarms

The Alarm manager can be accessed by selecting **Alarms** from the Homescreen.

Example: Active alarms tab



The Active alarms tab lists all alarms that are currently active. Alarms will remain active until the conditions that triggered the alarm are no longer present, e.g.: a Shallow depth alarm will automatically dismiss when the depth becomes deeper.

Alarm history

Example: Alarm history tab



All Dangerous (Red) and Warning (Orange) alarms will appear in the Alarm history list. The history list will include an entry for the alarm being triggered (raised) and also for when the alarm is acknowledged (cleared). The Alarm field contains the name of the alarm and the events field contains details of the alarm condition and its time and date.

The Alarm history list can be cleared by selecting **Clear history**.

Active alarm indication

Your MFD can be configured to provide active alarm indication from the Homescreen and from MFD apps. When enabled the Homescreen **Alarms** icon and MFD app's Home icon will indicate that an alarm is currently active.

Active alarm indication can be enabled and disabled from the alarms settings tab: **Homescreen > Alarms > Settings > Home button active alarm indicator**.

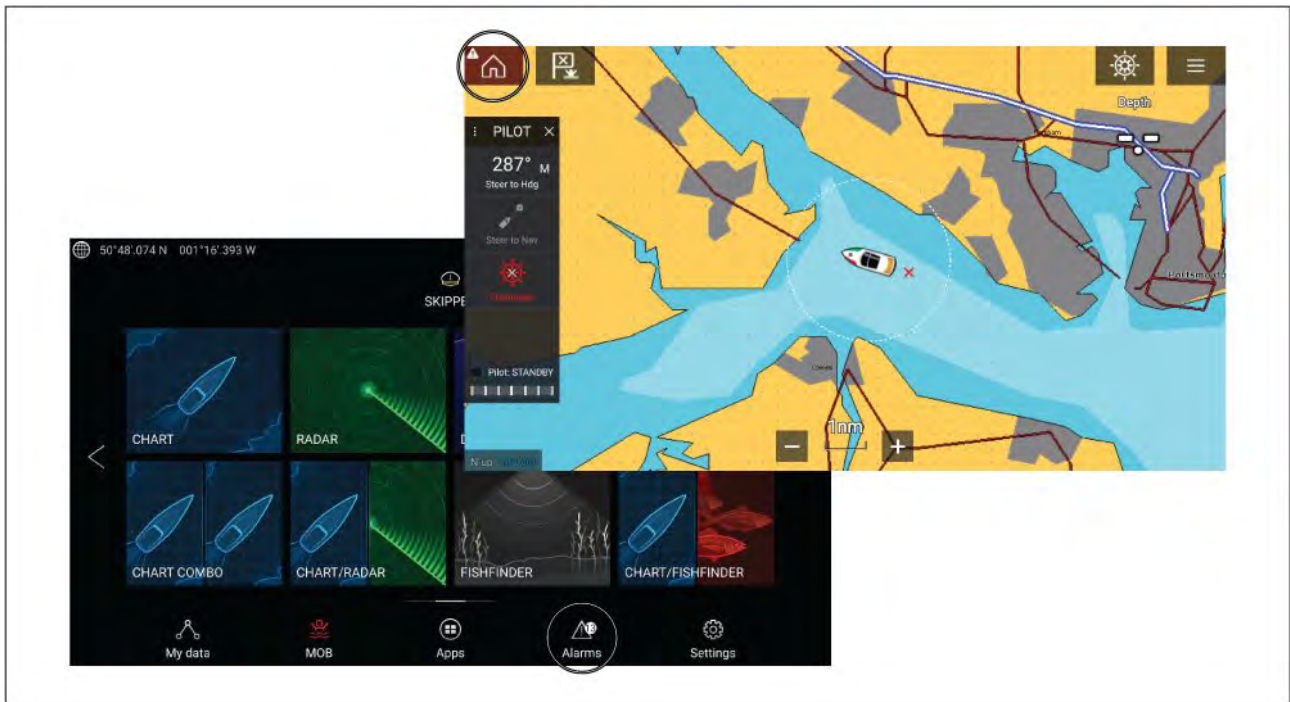

The Home icon will turn Red and have an exclamation mark placed inside it.

The Homescreen Alarms icon will display the number of active alarms.

Alarm settings

Depending on connected peripheral hardware and MFD configuration the alarms listed below can be enabled and disabled and where applicable alarm thresholds can be set or changed.

Note:

Alarms are only triggered when relevant hardware (e.g.: sensors) is connected and reporting the data required for the alarm.

- **Dangerous Radar targets**— If enabled, an alarm is triggered when Radar targets become dangerous. Radar targets are deemed dangerous when they have the potential to cross your path within a specified distance and time. For alarm parameters refer to: [p.280 – Dangerous targets alarm](#)
- **Lost Radar targets** — If enabled, an alarm is triggered when dangerous Radar targets become lost (i.e.: no Radar return from the target has been received for 20 seconds).
- **Dangerous AIS targets** — If enabled, an alarm is triggered when AIS targets become dangerous. AIS targets are deemed dangerous when they have the potential to cross your path within a specified distance and time. For alarm parameters refer to: [p.152 – Dangerous targets alarm](#)
- **Guard zone 1** — If enabled, an alarm is triggered when Radar returns are detected within guard zone 1.
- **Guard zone 2** — If enabled, an alarm is triggered when Radar returns are detected within guard zone 2.
- **Waypoint arrival** — If enabled, when you arrive at a waypoint, an alarm is triggered. This setting allows you to specify a radius size for three types of arrival alarm. When your vessel crosses the specified radius, the Waypoint Arrival alarm is triggered. The following Waypoint arrival alarms are available:
 - **Arrival radius** — Used when the MFD is NOT in pilot integration mode and the Autopilot is in Track mode.
 - **Pilot track mode radius** — Used when the MFD is integrated with an Autopilot and the Autopilot is in Track mode.
 - **Search route arrival radius** — Used when the MFD is following a SAR pattern. Also helpful when race sailing and using Laylines, or when fishing, as this alarm setting provides a smaller radius to ensure you don't get alerted too far away from the target waypoint.

- **Interception arrival** — If enabled, during target interception an alarm is triggered when your vessel reaches the distance specified in **Arrival radius**.
- **Off track** — If enabled, during active navigation an alarm is triggered when your vessel steers off track by more than the specified **Cross track error** value.
- **Anchor drift** — If enabled, an Alarm is triggered when your vessel drifts from your anchor position by more than the specified **Drift range**.
- **Low fuel remaining** — If enabled, an alarm is triggered when the fuel remaining in your fuel tanks reaches the specified **Fuel level**.

Note: The Fuel manager must be enabled for alarms to be triggered.

- **LightHouse chart obstructions**, If enabled, an alarm is triggered when an obstruction is detected. For details refer to: [p.161 — Obstruction alarm \(LightHouse charts\)](#)
- **DSC alarms** — If enabled, an alarm is triggered when DSC distress calls are received.
- **AIS safety messages** — If enabled, an alarm is triggered when AIS safety messages are received.
- **MOB data type** — Determines whether the MOB waypoint is fixed at the **Position** the alarm was triggered, or advances its position based on tide and wind effects (**Dead reckoning**).
- **Fishing range** — If enabled, an alarm is triggered when your Depth reading reaches the depth specified in **Shallow water arrival** or **Deep water arrival**.
- **Water temperature alarm** — If enabled, an alarm is triggered when the water temperature reading reaches the temperature specified in **Lower temp limit** or **Upper temp limit**.
- **Digital switching alarms** — When your system includes Digital switching a list of all configured Digital switching alarms will be displayed.
- **AX8 camera messages** — If enabled, messages from a connected AX8 camera will be presented as alarms on your MFD.
- **Engine alarms** — If enabled, alarms will be triggered when engine warning alarms are received from connected, compatible engine management systems or interfaces.
- **Home button active alarm indicator** — If enabled, when an alarm is active the onscreen Home icon is colored Red and contains a warning triangle.

External alarm speaker / buzzer

If your MFD has a built-in buzzer or is connected to a wired external buzzer then MFD alarms will trigger an audible tone. If you connect your MFD to a Bluetooth speaker then the alarm tone can also be heard from the speaker as well.

When connected to a Bluetooth speaker a separate volume control is available to control the volume of MFD Alarms sounded through the speaker. Please refer to the [Bluetooth speaker pairing](#) details.

Acknowledging alarms

Follow the steps below to acknowledge an active alarm.

With an alarms notification displayed onscreen:

1. Select **OK**.

The notification is dismissed and the audible tone is stopped.

An acknowledged alarm remains active until the conditions that triggered the alarm are no longer present.

Note:

If an alarm notification includes an **Edit** button, selecting it will display the relevant setting in the Alarms menu so that, if required, you can change the alarm threshold.

Digital switching alarms

When your MFD is connected to a Digital switching system, alarms specific to your installation can be enabled and disabled using the Alarm manager.

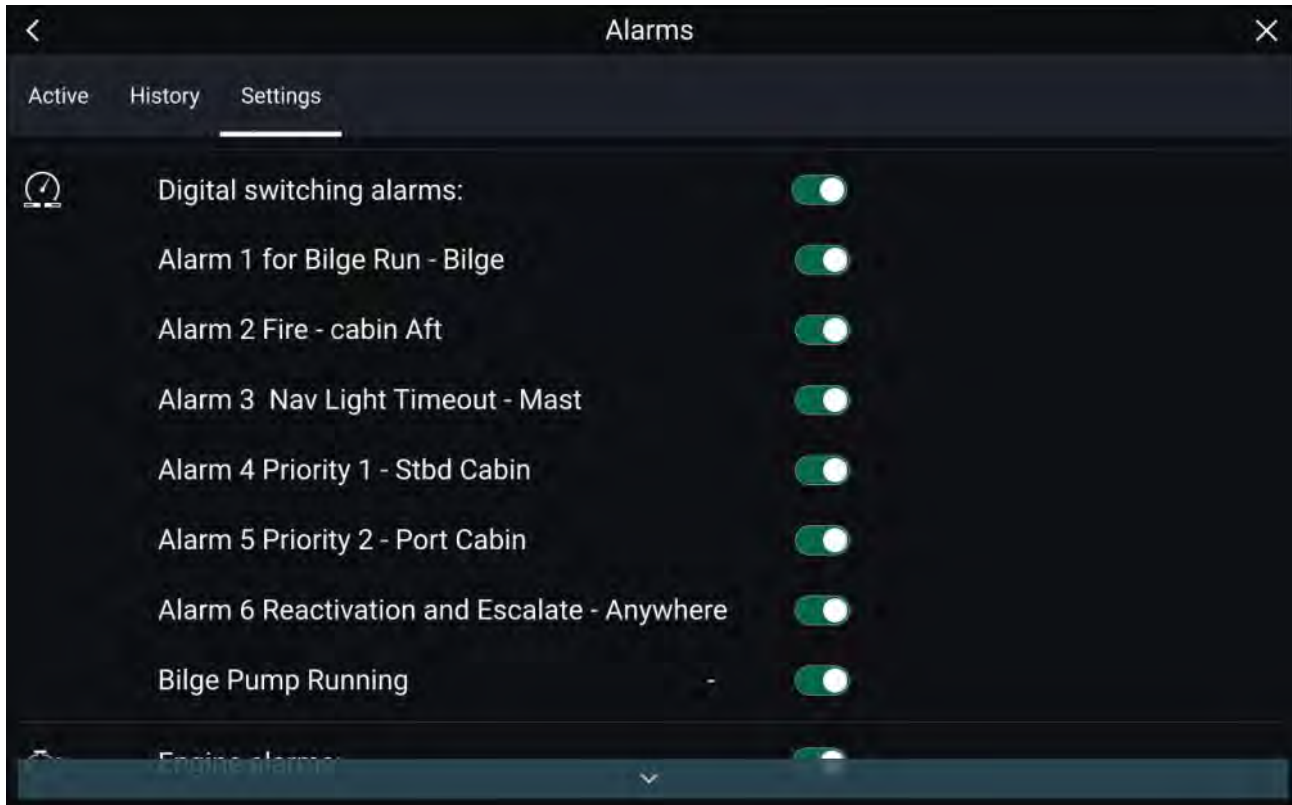

Example: Digital switching alarms



Each Digital switching system may be unique, with the alarms being defined when your system was configured.

5.10 Man Overboard (MOB)

If a person or object falls overboard, you can use the Man Overboard (MOB) feature to mark the position that your vessel was at when the MOB alarm was activated.

	The MOB feature can be activated by pressing and holding on the MOB icon on the Homescreen.
	The MOB waypoint icon displayed at the top of all apps.

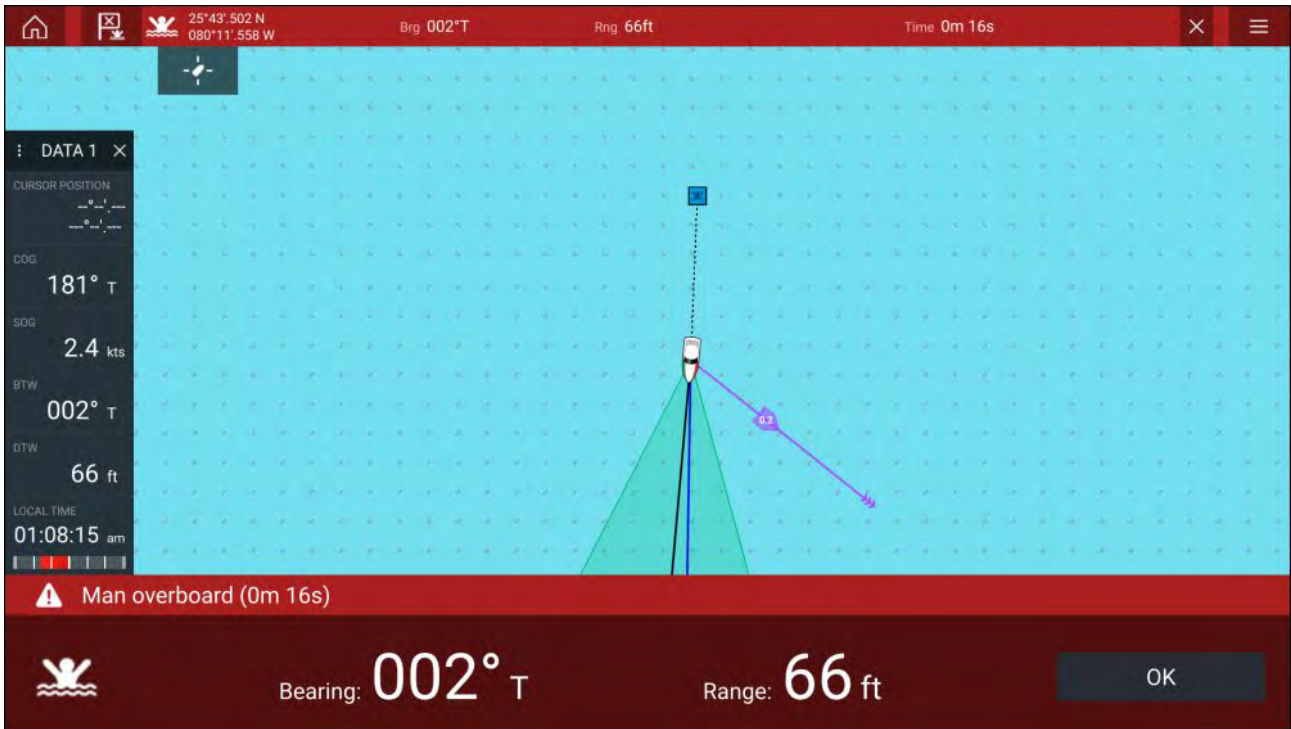

The MOB feature requires your vessel to have a valid position fix from a GNSS (GPS) receiver. Dead reckoning mode also requires Heading and Speed data.

When you activate the MOB alarm:

- an audible alarm is sounded which is repeated every 30 seconds until the alarm is cancelled.
- a MOB Databar providing Bearing and range from MOB, and elapsed time since MOB was initiated, is displayed along the top of the screen. The Databar persists across apps and the Homescreen, and remains until the MOB alarm is cancelled.
- a MOB warning is displayed in the bottom of the screen, which requires acknowledgement.
- the Chart app is placed in a special MOB mode to help you navigate back to the point your vessel was at when the MOB was initiated.

MOB mode

MOB can be set to Dead Reckoning or Position mode. Dead Reckoning mode will take into consideration the effects of wind and tides. This usually provides a more accurate course. Position mode does not take these factors into account. You can change the MOB mode at anytime from the Alarms menu: **Homescreen > Alarms > Settings > MOB data type:**

5.11 DSC VHF radio integration

The MFD can display DSC distress alert information received by a connected DSC VHF radio.

When DSC alarms are enabled (**Homescreen > Alarms > Settings > DSC alarms**), if a DSC distress call is received by your DSC VHF radio a notification is also displayed on the MFD.

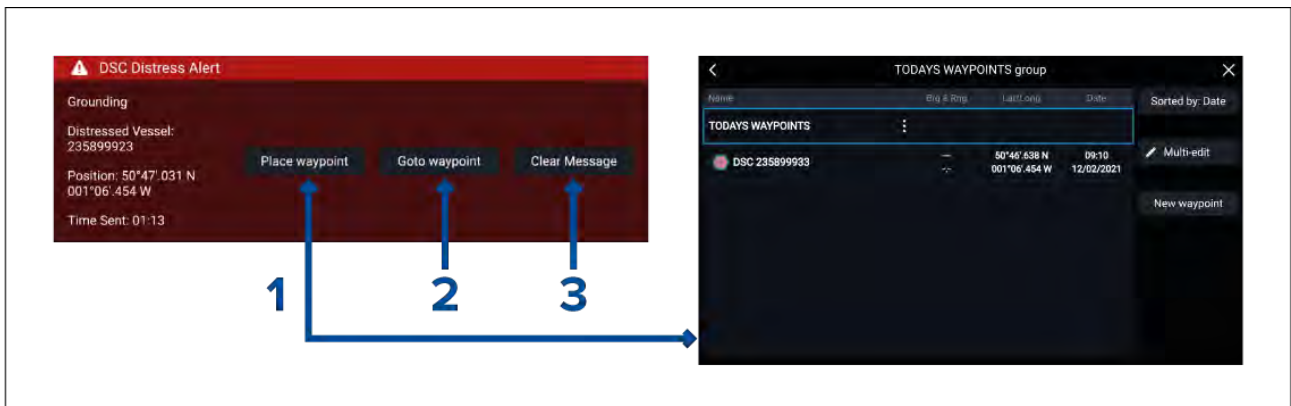

1. **Place waypoint** — Selecting **Place waypoint** places a waypoint at the latitude and longitude specified in the notification. The special DSC waypoint symbol is used for waypoints created from DSC notifications. DSC waypoints use the MMSI of the originating vessel as the waypoint name. If subsequent DSC distress calls are received from the same vessel MMSI then after selecting **Place waypoint** there will be 2 options to choose from:
 - **Replace waypoint** — Selecting **Replace waypoint** will replace the existing waypoint with a new waypoint using the updated notification details.
 - **Place new waypoint** — Selecting **Place new waypoint** will create a new waypoint and add a suffix (A.B.C etc.) to each new waypoint's name.
2. **Goto waypoint** — Selecting **Goto waypoint** sets a goto to the latitude and longitude specified in the notification.
3. **Clear message** — Selecting **Clear message** clears the alert from the screen.

Note:

If position data is not included in the DSC notification then **Place waypoint** and **Goto waypoint** options will not be available.

5.12 Settings

The Settings menu is accessible from the bottom of the Homescreen and contains important information and settings for your MFD.

The **Settings** menu is divided into different tabs, the settings available are:

Tab	Settings
Getting started	<ul style="list-style-type: none"> • View hardware and software information about your MFD. • View cartography details for inserted chart cards. • Update MFD software • View the LoU disclaimer (Getting started tab). • Change the user interface language. • View the Regulatory approvals.
Boat details	<ul style="list-style-type: none"> • Set boat icon and name. • Configure Sailing [Sailing vessel's only]. • Configure Minimum safe depth, height and width. • Configure engines. • Configure batteries. • Configure fuel tanks.
Units	<ul style="list-style-type: none"> • Configure preferred units of measurement. • Configure Bearing mode. • Configure variation. • Configure GNSS (GPS) system datum. • Set time differentials.

Tab	Settings
This display	<ul style="list-style-type: none"> • Color theme (day mode). • Assign a Homescreen page or app to start on power up. • Select save location for screenshots. • ⁽¹⁾Configure User Programmable Button (UPB; Axiom Pro displays only). • Configure Shared brightness. • ⁽²⁾Change or reset Splashscreen graphic. • Pair / unpair connected RMK external keypads. • ⁽³⁾Enable / disable external alarm output. • ⁽²⁾Connect to a wireless display. • Wi-Fi Sharing, pair with a wireless Quantum Radar scanner, configure Wi-Fi settings and set up mobile app access. • ⁽²⁾Connect to a Bluetooth device. • Perform a Settings or Factory reset.
Autopilot	<ul style="list-style-type: none"> • Enable / Disable Autopilot control. • Set autopilot response. • Access advanced autopilot settings.
Network	<ul style="list-style-type: none"> • View list of networked MFDs. • Assign the MFD Data master. • View software and network details for the MFD you are using. • Rename connected network devices. • Save or Erase diagnostics logs to external storage. • View and Save Diagnostic information about products connected to your MFD. • ⁽⁴⁾Set up NMEA 0183 options on an Axiom Pro. • Assign your preferred data sources (Data master only).
Responder	<p>The Responder menu tab is only available when First responder is selected as the 'Boating activity' during step 2 of the MFD's initial startup wizard. The Responder menu includes settings for STEDS specific features, which require an AIS5000 to be connected to the system. .For details refer to: p.208 – Responder setup</p>

Note:

- (1) Available on Axiom™ Pro MFDs.
- (2) Available on Axiom™, Axiom™ Pro and Axiom™ XL MFDs.
- (3) Available on Axiom™ XL and gS Series MFDs.
- (4) Available on Axiom™ Pro, Axiom™ XL, eS Series and gS Series MFDs.

Selecting display language

You can choose which language you want the display's user interface to use.

1. Select the **Language** button from the **Getting started** menu: **Homescreen > Settings > Getting started > Language**.
2. Select your desired language.

User Interface languages

The following languages are available:

Arabic (ar-AE)	Bulgarian (bg-BG)	Chinese (Simplified) (zh-CN)	Chinese (Traditional) (zh-TW)
Croatian (hr-HR)	Czech (cs-CZ)	Danish (da-DK)	Dutch (nl-NL)
English (en-GB)	English (en-US)	Estonian (et-EE)	Finnish (fi-FI)
French (fr-FR)	German (de-DE)	Greek (el-GR)	Hebrew (he-IL)
Hungarian (hu-HU)	Icelandic (is-IS)	Indonesian (Bahasa) (id-ID)	Italian (it-IT)
Japanese (ja-JP)	Korean (ko-KR)	Latvian (lv-LV)	Lithuanian (lt-LT)
Malay (Bahasa) (ms-MY ZSM)	Norwegian (nb-NO)	Polish (pl-PL)	Portuguese (Brazilian) (pt-BR)
Russian (ru-RU)	Slovenian (sl-SI)	Spanish (es-ES)	Swedish (sv-SE)
Thai (th-TH)	Turkish (tr-TR)	Vietnamese (vi-VN)	

Boat details

To ensure correct operation and display of data you should set the Boat Details settings according to your requirements.

Boat details can be accessed from the **Settings** menu: **Homescreen > Settings > Boat Details**

Option	Description
Boat /Icon:	Selection determines the icon used to signify your vessel in the Chart app.
Boat Name:	Configures your system with your vessel's name.
[Sailing only] Sail performance:	Select Fixed Angles or Polar laylines.
[Sailing only] Boat type:	Select your vessel's Boat type to provide more accurate leeway calculations.
[Sailing only] [Fixed Angles only] Upwind angle:	Set the angle of upwind layline calculations.
[Sailing only] [Fixed Angles only] Downwind angle:	Set the angle of downwind layline calculations.
[Sailing only] [Polar only] Polar:	Select the Polar table that will define your layline calculation.
Min safe height:	Enter your vessel's maximum unladen height from the waterline. To ensure adequate clearance, it is recommended that you add a safety margin to this figure to allow for variation caused by vessel movements.
Min safe width:	Enter your vessel's maximum width at its widest point. To ensure adequate clearance on both sides, it is recommended that you add a safety margin for port and starboard to this figure to allow for variation caused by vessel movements.
Min safe depth:	Enter your vessel's maximum depth when fully laden. This is the depth from the waterline to the lowest point on the vessel's keel. To ensure adequate clearance, it is recommended that you add a safety margin to this figure to allow for variation caused by vessel movements.
Num of engines:	Select the number of engines on your vessel. When connected to a compatible system, your MFD can monitor engine data.
Identify engines:	Once you have selected the number of engines, select Identify engines and follow the onscreen instructions to configure your engines. May require an extra hardware interface to enable engine data to be displayed.

Option	Description
Engine manufacturer:	To interface with Yamaha , Yamaha HDMI and Mercury gateways select the relevant manufacturer from the list. Otherwise select Other .
[Num of engines 2 only] Configure Yamaha Quad display:	Select whether your MFD is displaying for a twin engine system, or for the port or starboard side of a quad engine system.
Num of Batteries:	Configures your system with the number of batteries on your vessel.
Tanks:	Calibrate your vessel's tanks.
Num of interior environment sensors:	Allows the display of multiple instances of interior temperature and humidity sensor's data. Up to 10 sensors can be used.

Calibrating tanks

When displaying tank levels on your MFD it's important to ensure the levels are correctly calibrated. Failure to do so may result in inaccurate level readings.

Tanks can be calibrated and edited on the Boat details page: **Homescreen > Settings > Boat details**.

Tanks can be calibrated with the following Oceanic Systems tank senders:

- 3271 Volumetric Fuel Sender
- 3281 Water Level Senders
- 3125 Tank Sender Adapter
- 4291 Tank Level Adapter



Note:

- Ensure tanks are empty before calibration.
- Completing calibration will overwrite any existing calibration already recorded.

1. Press configure
2. Select the tank you want to calibrate; a dialog will be displayed
3. Set the tank's capacity
4. Select calibrate and choose the desired method for tank calibration:
 - i. Run wizard
 - ii. Import calibration

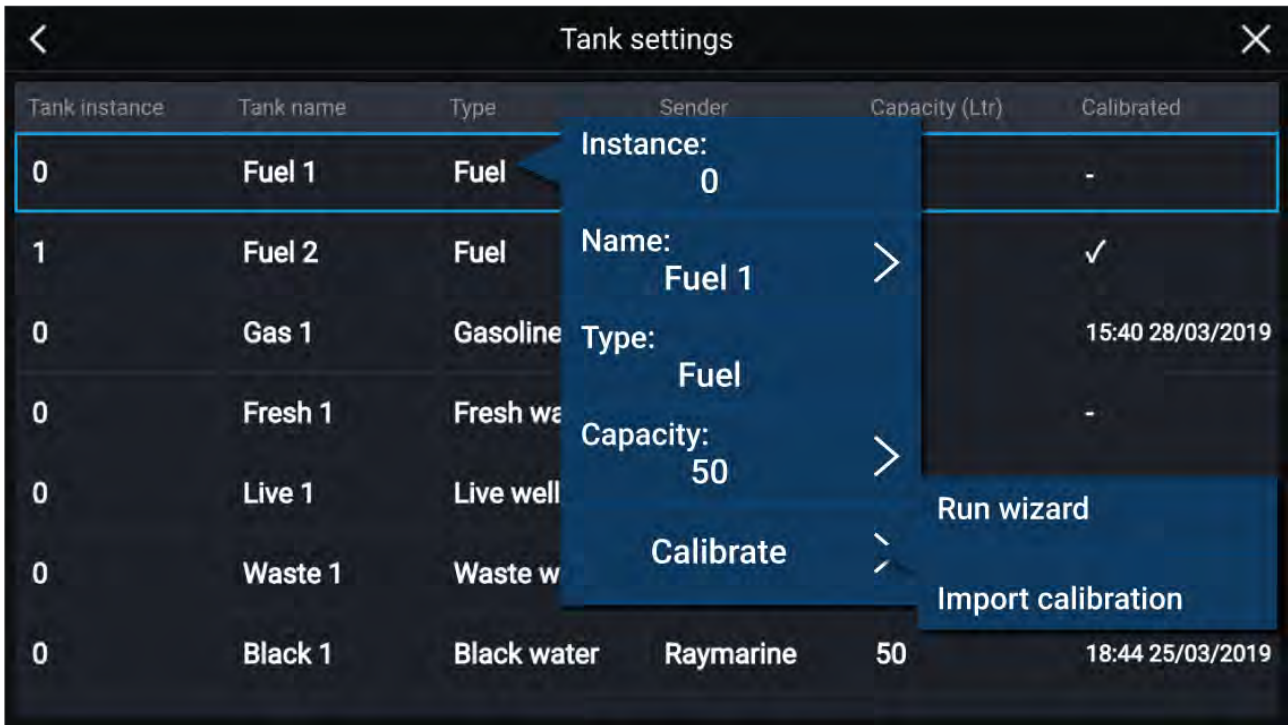

Run wizard calibration

You can calibrate your tank by setting a series of **calibration points** and filling your tank in intervals. The shape of your tank determines how many calibration points you should enter for calibration. 2 calibration points are required as a minimum, but up to 101 points can be entered. Generally, the more calibration points entered the more precise tank readings will be.

Additional calibration points are used to account for changes in tank volume at different parts of an irregularly shaped tank. Depending on the size and shape of your tank it is recommended that you enter calibration points to mark each change in the shape of the fuel tank; for example, straight corners require an additional point, and slopes require 2 points.

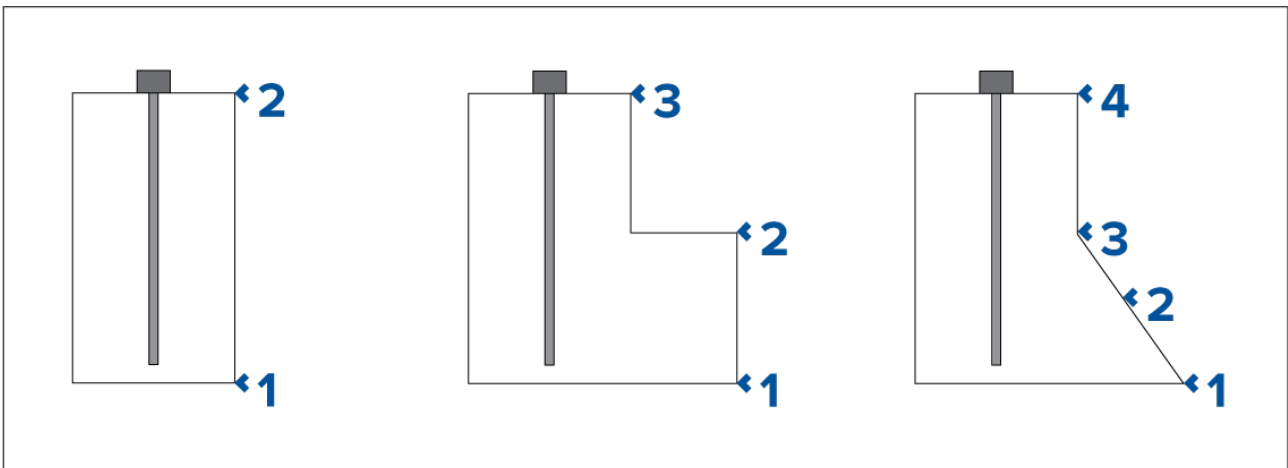

The illustration above shows the minimum number of calibration points recommended for some typical tank shapes:

1. The tank shown on the left is rectangular and symmetrical; it only requires 2 calibration points to define the bottom and top of the tank.
2. The tank shown in the center has a greater volume at the bottom; 3 points are required to define the bottom, top and corner of the fuel tank.
3. The tank shown on the right has a greater volume at the bottom and is sloped. 4 points are required to define the bottom of the tank, the top, and a further 2 points to define the slope.

Wizard Calibration

1. Select the number of calibration points (minimum of 2) and press **next**.
2. Fill the tank to the units displayed on screen and press **Ok**.
3. To complete the calibration process, repeat step 2 until the tank has been filled.

Import calibration

You can calibrate your tanks by importing CSV files that contain specific tank calibration data. These files are typically supplied by tank manufacturers or dealers.

Note: CSV files used for import calibration must start with: '0,0' and end in: '100,100'

To **Import calibration** via CSV file:

1. Select the appropriate CSV file from the file explorer.
2. Press **Yes**.

Units of measure

You can select your preferred units for data readings from the **Units** tab of the **Settings** menu:

Homescreen > Settings > Units.

Measurement	Units
Distance units	<ul style="list-style-type: none">• Nautical Miles• NM & m• Statute Miles• Kilometers
Speed units	<ul style="list-style-type: none">• Kts• MPH• KPH
Depth units	<ul style="list-style-type: none">• Meters• Feet• Fathoms
Temperature units	<ul style="list-style-type: none">• Celsius• Fahrenheit
Date format	<ul style="list-style-type: none">• MM : DD : YYYY• DD : MM : YYYY• MM : DD : YY• DD : MM : YY
Volume units	<ul style="list-style-type: none">• US Gallons• Imperial Gallons• Liters
Economy units	<ul style="list-style-type: none">• Distance per Volume• Volume per Distance• Liters per 100 km
Wind speed units	<ul style="list-style-type: none">• Knots• Meters per Second
Pressure units	<ul style="list-style-type: none">• Bar• PSI• Kilopascals
Time format	<ul style="list-style-type: none">• 12hr• 24hr

Data master

Systems containing more than one MFD must have a designated Data master MFD. The Data master is the primary MFD in the network, and should be the MFD that is physically connected to the SeaTalkng® / NMEA 2000 CAN bus network, and any other devices and sources of data in your system. The Data master bridges the data over the SeaTalkngs™ network to any compatible networked 'repeater' MFDs.

Information shared by the Data master includes:

- Cartography
- Waypoints, Routes and Tracks
- Radar
- Sonar
- Data received from the autopilot, GNSS (GPS) receiver, instruments, transducers, the engine and any other compatible external sources.

Note: Your system may be wired for redundancy with data connections made to repeat displays. However these connections will only become active in the event of a fault and / or reassignment of the data master.

Switching Data Master

You can switch the MFD you want to be the Data master at any time.



From the Network tab: **Homescreen > Settings > Network:**

1. From the list, select the MFD you want to designate as the new Data master.
2. Select **Assign as Data Master** from the pop-over options.

Shared Brightness

Shared brightness enables simultaneous brightness adjustment of all products that are part of the same group.

The following products are compatible with shared brightness:

- LightHouse™ 3 MFDs using software version 3.4 or greater.
- LightHouse™ or LightHouse™ 2 powered MFDs.
- SeaTalkng® Instrument displays and Pilot controllers.
- SeaTalkng® VHF DSC Radios.
- RMK-9 and RMK-10 remote buttonpads.

Any adjustments to the shared brightness level will be applied to all products assigned to the same group.



Multiple brightness groups can be configured. For example, these groups could be used to reflect the physical location of products on your vessel e.g.: helm and flybridge.

Shared brightness requires:

- all products to be compatible with the shared brightness function (see list of compatible products above).
- the **Shared brightness** setting set to On for all products in the brightness group.
- products to be assigned to network groups.
- all the products in each group to be synchronized.

Setting up shared brightness

Before setting up Shared brightness on your MFD, ensure that all displays that you want to use Shared brightness are switched on and set to the same Display group as your MFD.

1. Select **This display** from the **Settings** menu: **Homescreen > Settings > This display**.
2. Select **Display group**.
A list of available display groups is displayed.
3. Select the Display group that you want the MFD to be part of (All displays that you want to share brightness with must be set to the same group).
4. Enable **Shared brightness** using the Toggle switch.
5. Select **Sync**.

'Shared brightness active' is displayed when complete.

Customizing the splashscreen

The standard AXIOM splashscreen, displayed on start up, can be customized on Axiom™, Axiom™ Pro, and Axiom™ XL displays.

Custom Image requirements:

- The customized image must be in .png, .bmp or .jpg format.
- Custom images cannot exceed the maximum resolution supported by your MFD.
- For optimum image quality, the resolution of the splashscreen image should match the resolution of your MFD. Refer to the following table: [Axiom screen resolutions](#).

Note:

- Splashscreen settings are unique to each MFD and are not shared across the network with other MFDs.
- Custom splashscreens are not available on eS Series and gS Series MFDs that have been upgraded to run LightHouse 3 software.

1. Save your custom image to a MicroSD card and insert the card into a card reader slot on your MFD or connected card reader.
2. Select **This display** from the **Settings** menu: **Homescreen > Settings > This display**.
3. Select the image name next to **Splashscreen**:
The file browser is displayed.
4. Browse to your custom image and select it.
5. Select **Yes**.
The image is imported to your MFD's internal storage.

The next time your MFD powers up, your custom image will be displayed.

Axiom screen resolutions

The screen resolutions for Axiom™, Axiom™ Pro, and Axiom™ XL displays are shown below.

MFD variant	Screen resolution (W x H)
Axiom™ 7+	1024 x 600
Axiom™ 9+	1080 x 720
Axiom™ 12+	1280 x 800
Axiom™ 7	800 x 480
Axiom™ 9	800 x 480
Axiom™ 12	1280 x 800
Axiom™ Pro 9	1280 x 720
Axiom™ Pro 12	1280 x 800
Axiom™ Pro 16	1920 x 1080
Axiom™ XL 16	1920 x 1080
Axiom™ XL 19	1920 x 1080
Axiom™ XL 22	1920 x 1080
Axiom™ XL 24	1920 x 1200

Resetting the splashscreen graphic

1. Select **This display** from the **Settings** menu: **Homescreen > Settings > This display**.
2. Select the **Reset** from the Splashscreen section.
3. Select **Yes**.

The next time your MFD starts up the standard AXIOM splashscreen will be displayed.

NMEA 0183 settings

NMEA 0183 devices can be connected to Axiom™ Pro, Axiom™ XL, eS Series, and gS Series MFDs using the NMEA 0183 wires on the supplied Power/Video/NMEA 0183 cable.

2 NMEA 0183 ports are available:

- **Port 1:** Input and output, 4,800 or 38,400 baud rate.
- **Port 2:** Input only, 4,800 or 38,400 baud rate.

The baud rate for each input port must be specified in the **NMEA set-up** menu (**Homescreen > Settings > Network > NMEA set-up**).

Note:

- For Port 1, both the input and output communicate at the same baud rate. For example, if you have one NMEA 0183 device connected to Port 1 INPUT, and another NMEA 0183 device connected to Port 1 OUTPUT, both NMEA devices must use the same baud rate.

NMEA 0183 settings

The following options are available from the **NMEA Set-up** menu.

Menu item	Description	Options
NMEA Port 1	Baud rate selection.	<ul style="list-style-type: none"> • 4,800 • 38,400
NMEA input port 2	Baud rate selection.	<ul style="list-style-type: none"> • 4,800 • 38,400
Bridge heading	Bridge heading data from NMEA 0183 to NMEA 2000 / SeaTalkng®	<ul style="list-style-type: none"> • Yes • No
Transmission mode	<p>Switches between Single-ended and Differential transmission modes. The Differential transmission mode supports higher speeds, longer cable runs, and better data integrity. Differential mode works when connected to opto-isolated inputs, as specified by the NMEA 0183 standard. The Single-ended mode is required when sending a signal to a single-ended receiver device, such as a PC for example. Refer to the <i>NMEA 0400 Installation Standard</i> for wiring guidelines for the different transmission modes.</p> <p>Note: Only available on Axiom™ Pro and Axiom™ XL displays.</p>	<ul style="list-style-type: none"> • Single-ended • Differential
Individual outputs	List of NMEA 0183 sentences for which the output can be disabled.	<ul style="list-style-type: none"> • Enabled • Disabled

5.13 Connecting to a wireless display

Axiom™, Axiom™ Pro, and Axiom™ XL MFDs can be connected to a wireless display using an external dongle or a display that has built-in support. When connected the MFD's screen is mirrored on the wireless display.

1. Follow the instructions provided with your wireless display / dongle to set up that specific device.
2. On the MFD, select the display icon found under **Wireless display:** on the **This Display** tab of the **Settings** menu: (**Homescreen > This Display > Wireless Display:**).

Your MFD will search for available wireless displays.



3. Select the display you want to use.
4. If your MFD has Wi-Fi Sharing enabled then a PIN number is displayed on the wireless display, input this pin number when requested by your MFD.
5. You may also be requested to allow the MFD to connect automatically in future, select **Yes** or **No** as appropriate on your wireless display.
Your MFD screen will now be displayed on the select device.
6. To allow the wireless display to connect each time your MFD is powered on, enable **Connect on power up** from the pop-over options.



Note:

1. Don't forget to check your wireless display for any required confirmations / acknowledgements during the connection process.
2. Some non Miracast-certified devices may not be able to connect with Wi-Fi Sharing enabled, in this case disable Wi-Fi Sharing and try again.
3. If you experience connection issues, try disabling and enabling the wireless display feature on your display and MFD, or power cycle both devices.
4. Once connected / paired to a wireless display do not change your MFD's Wi-Fi Passphrase, as on certain devices a factory reset maybe required to re-establish a connection.

Disconnecting a wireless display

With a wireless display connection active:

1. Select Disconnect from the **This Display** tab: (**Homescreen > Settings > This Display > Wireless Display: > Disconnect**).

Unpairing a wireless display

With the wireless display connection active:

1. Select the connected display from the Wireless display menu: (**Homescreen > Settings > This Display > Wireless Display:**).
2. Select the connected display from the list of available displays.
3. Select **Unpair** from the pop-over menu.

Chapter 6: Autopilot control

Chapter contents

- [6.1 Commissioning - Evolution autopilot system on page 96](#)
- [6.2 Autopilot control on page 102](#)
- [6.3 Pilot sidebar on page 104](#)
- [6.4 Pilot pop-up on page 106](#)
- [6.5 Autopilot Control — Pilot set-up menu on page 106](#)
- [6.6 Rudder damping levels and deadband angles on page 109](#)

6.1 Commissioning - Evolution autopilot system

Commissioning pre-requisites

Before commissioning your autopilot system for the first time, check that the necessary processes have been carried out correctly.

Important:

You should read through and understand the entire commissioning instructions for your autopilot system before beginning the commissioning process.

Before commissioning, check the following:

- all autopilot system components have been installed in accordance with the installation instructions supplied with the system components.
- all autopilot system components have been updated to the latest available software revisions. Check the Raymarine website for available software updates: <http://www.raymarine.co.uk/software>
- a system schematic is available or has been created which includes all system components and required connections.
- the commissioning engineer is familiar with the vessel's hull type, drive type and steering system.

Commissioning steps

The required commissioning steps should be carried out in the correct order using the pilot controller display.

Note:

Commissioning must be performed using the Data master MFD.

1. Power-up all of the components that make up your autopilot system.
2. Select the relevant vessel hull type for your vessel.
3. Complete the dockside calibration process., using the **Dockside wizard**:
4. If the system does NOT include a rudder reference transducer then, specify the hard-over time.
5. Complete compass linearization.
6. If required, lock the compass.

Vessel hull type selection

The vessel hull type options are designed to provide optimum steering performance for typical vessel s.

It is important to complete the vessel hull type selection, prior to performing dockside calibration, as it forms a key part of the commissioning process. The vessel hull type options can be accessed at any time, when the autopilot is in Standby from the **Pilot set-up** menu: **Homescreen > Settings > Autopilot > Pilot set-up > Vessel Hull Type**.

The option that most closely matches your vessel's hull type and steering characteristics should be selected from the available hull types:

- **Power**
- **Power (slow turn)**
- **Power (fast turn)**
- **Sail**
- **Sail (Slow turn)**
- **Sail Catamaran**

Note:

It is important to be aware that steering forces (and therefore rate-of-turn) vary significantly depending on the combination of vessel hull type, steering system, and drive type. The available vessel hull type options are provided for guidance only. You may wish to experiment with the different vessel hull type options, as it might be possible to improve the steering performance of your vessel by selecting a different vessel hull type. When choosing a suitable vessel hull type, the emphasis should be on a safe and dependable steering response.

Using the Dockside wizard

The dockside calibration process must be completed before the autopilot system can be used for the first time. The Dockside wizard guides you through the steps required for dockside calibration.

The Dockside wizard contains different steps depending on whether the system includes rudder reference transducer:

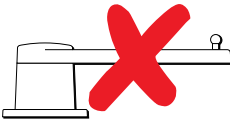
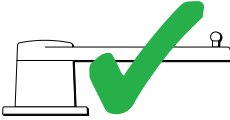
	<p>The following Dockside wizard procedures apply to vessels that do not have a rudder reference transducer:</p> <ol style="list-style-type: none"> 1. Drive Type selection. 2. Rudder Limit setting. 3. Hard-over time setting (Raymarine recommends that this information is specified once the dockside wizard and Rudder Drive check is complete, using the Hard Over Time menu option). 4. Rudder Drive check.
	<p>The following Dockside wizard procedures only apply to vessels that include a rudder reference transducer:</p> <ol style="list-style-type: none"> 1. Drive Type selection 2. Rudder alignment (Align Rudder) 3. Rudder Limit 4. Rudder Drive check.

To access the wizard, ensure the autopilot is in standby and then:

1. Select **Dockside Wizard** from the **Advanced settings** menu **Homescreen > Settings > Autopilot > Pilot set-up > Dockside wizard**.
2. Select **Continue** to initiate the dockside wizard and follow the onscreen instructions.

Selecting a drive type

Drive type selection is included in the dockside wizard.

With the **Drive Type** menu displayed:

1. Select your drive type.

The drive types available are:

- Type 1 Linear
- Type 2 Linear
- Type 2 Hydraulic Linear
- Type 3 Hydraulic Linear
- I/O Stern
- Wheel Drive
- Tiller
- Sport Drive
- Verado
- Rotary Drive Type 1
- Rotary Drive Type 2
- Hydraulic Pump Type 1
- Hydraulic Pump Type 2

- Hydraulic Pump Type 3

Important:

If your drive type is not listed, contact your Raymarine dealer for advice.

2. Select **Continue**.

Drive type selection is also available when the autopilot is in standby, from the **Advanced settings** menu: **Homescreen > Settings > Autopilot > Pilot set-up > Drive type**.

Aligning the rudder

For systems that have a rudder reference transducer fitted, Rudder alignment is included in the dockside wizard and comes after drive type selection. For systems without a rudder reference transducer fitted rudder alignment is not required.

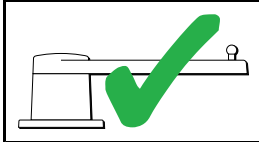

- The following procedure only applies to vessels with a rudder reference transducer.

1. Select **Continue**.
2. Center the rudder and select **OK**.
3. Put the rudder all the way to port and press **OK**.
4. Put the rudder all the way to starboard and press **OK**.
5. Center the rudder and select **OK**.
6. Select **Continue** when the task complete message is displayed to progress to the rudder limit page.

Setting the rudder limit

Rudder limit setting is included in the dockside wizard and comes after rudder alignment or drive selection depending on whether a rudder reference transducer is fitted.

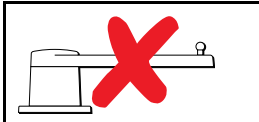

- For vessels without a rudder reference transducer
- Rudder limit are set to 30 degrees and can be adjusted as required.



- For vessels with a rudder reference transducer
- The rudder alignment process establishes the rudder limit. The rudder limit will be displayed with a message confirming that the rudder limit has been updated.
- If required, the limit can be adjusted.

1. Ensure that the rudder limit is sufficient to prevent the steering mechanism impacting the end stops and placing the steering system under unnecessary load. If required adjust the limit by selecting the rudder limit value box.

Important:

It is recommended that the limit is set to approximately 5 degrees less than the maximum rudder angle.

2. Select **Continue** to move to the next step.

Note:

The rudder limit can be adjusted when the autopilot is in standby, from the **Pilot set-up** menu: **Homescreen > Settings > Autopilot > Pilot set-up > Rudder Limit**.

Hard over time

The hard over time setting can be specified as part of the Dockside wizard and comes after setting the rudder limit.

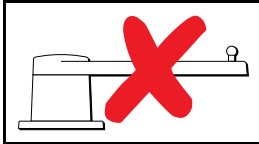

- The following information only applies to vessels without a rudder reference transducer.

- If you already know the hard-over time for your vessel's steering system: enter this time in the Hard over time value box and select Continue.
- If you do NOT know the hard-over time for your vessel's steering system, select **Continue**, proceed with the Checking the rudder drive procedure and complete the Dockside wizard. Once the wizard is complete, proceed to the Setting the hard-over time instructions for information on how to calculate and set the hard-over time.

Setting the hard-over time

On vessels without a rudder reference transducer, it is important to set a Hard Over Time.

Before attempting to follow this procedure ensure you have read and understood the Rudder Check warning provided in this document.

To estimate your hard over time follow the steps below:

1. With the autopilot in **Standby**, manually turn the rudder / engine full to port. (For vessels with power steering the engine should be running when turning the rudder.)
2. Open the sidebar by swiping right from the left side of the screen.
3. Switch to the Pilot sidebar.
4. Engage **Auto** mode.
5. Press the **+10** button on the Pilot bar 9 times to ensure that the rudder moves hard over to starboard.
6. Count how many seconds it takes for the rudder to move from hard over port to hard over starboard. This is your hard over time.
7. Enter your hard over time in the. The hard over time setting can be accessed from the **Pilot set-up** menu: **Homescreen > Settings > Autopilot > Pilot set-up > Hard over time**.
8. After setting the hard over time, observe the autopilot's behavior and if required, make small adjustments to the Hard over time value until a satisfactory result is achieved.



Warning: Rudder check

If no rudder reference has been fitted you **MUST** ensure that adequate provision is made to prevent the steering mechanism from impacting the end stops.

Checking the rudder drive (rudder reference fitted)

As part of the dockside wizard, the system will check the drive connection. Once it has completed the check successfully, a message will appear asking if it is safe for the system to take the helm.

During this procedure the autopilot will move the rudder. Ensure it is safe to proceed before proceeding.

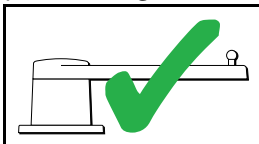

- The following procedure only applies to vessels with a rudder reference transducer.

1. Center and let go of the rudder.
2. Disengage any rudder drive clutch.
3. Select **Continue**.
4. Check it is safe to proceed and then select **OK**.
The autopilot will now automatically move the rudder.
5. Select **OK** when the rudder has moved to port.
6. Select **OK** when the rudder has moved to starboard.
7. Select **Continue** when the rudder has centered.
8. Dockside calibration is now complete, select **Continue**.

Checking the rudder drive (no rudder reference fitted)

As part of the dockside wizard, the system will check the drive connection. Once it has completed the check successfully, a message will appear asking if it is safe for the system to take the helm.

During this procedure the autopilot will move the rudder. Ensure it is safe to proceed before proceeding.

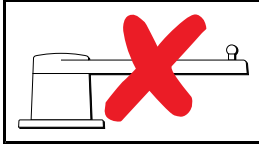

- The following information only applies to vessels without a rudder reference transducer.

1. Center and let go of the rudder.
2. Disengage any rudder drive clutch.
3. Select **Continue**.
4. Check it is safe to proceed and then select **OK**.
The autopilot will now automatically move the rudder.
5. You will be asked to confirm that the rudder has turned to port by selecting **YES** or **NO**.
6. Select **OK** if it is safe to engage the rudder in the opposite direction.
7. You will be asked to confirm the rudder turned to starboard by selecting **YES** or **NO**.
8. Dockside calibration is now complete, select **Continue**.

Note:

If you confirmed a “NO” response for the rudder movement to both port and starboard, the wizard will exit. It is possible that the steering system did not move the rudder in any direction, and it will be necessary to check the steering system before completing the Dockside wizard procedure again.

Important:

If you have not already done so, now set your Hard-over time using the following instructions:
[Setting the hard-over time](#)

Compass linearization — Evolution autopilots

The EV sensor’s internal compass needs to compensate for local and the Earth’s magnetic fields. This is achieved using an automatic process known as linearization.

Initial linearization

When the EV sensor is first installed and powered-up (or after a factory reset or compass restart) linearization is required. When linearization is in progress bar is displayed in the Autopilot settings page: **Homescreen > Settings > Autopilot**.

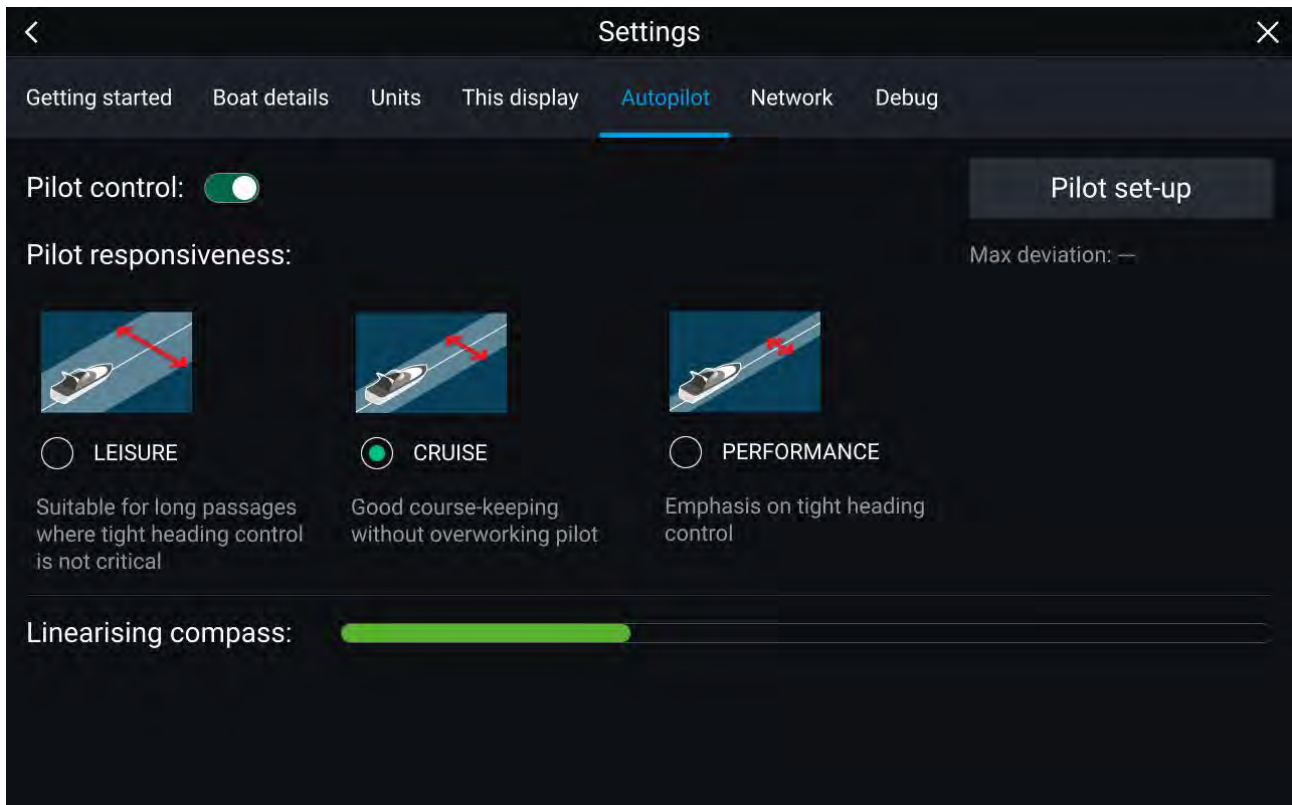

The linearization process will start automatically after your vessel has turned approximately 100° at a speed of between 3 –15 knots. Linearization requires no user input, however at least a 270° turn is required before linearization can complete. The progress bar will fill to indicate progress, the progress bar will turn Red if the process is paused or otherwise interrupted. Time it takes to complete the linearization will vary according to the characteristics of the vessel, the installation environment of the EV unit, and the levels of magnetic interference at the time of conducting the process. Sources of significant magnetic interference may increase the time required to complete the linearization process. Examples of such sources include:

- Marine pontoons
- Metal-hulled vessels
- Underwater cables

You can speed-up the linearization process by completing a full 360° turn (at a speed of 3 – 15 knots). You can also restart the linearization process at any time by selecting the **Restart Compass** from the Pilot set-up menu: **Homescreen > Settings > Autopilot > Pilot set-up**.

Once the initial linearization is completed the Maximum compass deviation value is displayed under the **Pilot set-up** button on the Autopilot settings page.

Compass deviation

If the reported deviation is 45° or higher, it is highly recommended that the EV sensor is moved and re-installed in a location which is subject to less magnetic interference.

Note:
If “-” is displayed as the Deviation value, it means that linearization has not been successfully completed yet.

Check the compass heading data

As part of the autopilot system commissioning process, it is recommended that you check the compass heading value displayed, against a good known heading source on various headings.

Note:
Once the linearization process has completed, it is possible that the heading value may have a slight offset of 2 to 3 degrees. This is common where installation space is limited, and the EV sensor cannot be properly aligned to the vessel's longitudinal axis. In this case, it is possible to manually adjust the **Compass offset** value.

The compass offset can be adjusted from the Pilot set-up menu: **Homescreen > Settings > Autopilot > Pilot set-up > Compass offset.**

Important:

Do NOT rely on the reported heading until compass linearization and alignment is complete.

System monitoring and adaptation

To ensure optimum performance, after the initial linearization process is complete the EV continues to monitor and adapt the compass linearization to suit current conditions.

If the conditions for linearization are less than ideal, the automatic linearization process temporarily pauses until conditions improve again. The following conditions can cause the linearization process to temporarily pause:

- Boat speed < 3 knots.
- Boat speed > 15 knots.
- Rate-of-turn is too slow.
- Significant magnetic interference is present.

Compass lock

Once you are satisfied with the compass accuracy, you can lock the setting to prevent the system from completing a further automatic linearization in the future.

This feature is particularly useful for vessels in environments that are exposed to strong magnetic disturbances on a regular basis (such as offshore wind farms or very busy rivers, for example). In these situations it may be desirable to use the Compass lock feature to disable the continuous linearization process, as the magnetic interference may build a heading error over time.

Note: The compass lock may be released at any time, to allow the compass continual monitoring and adaptation to re-commence. This is particularly useful if planning a long voyage. The earth's magnetic field will change significantly from one geographical location to another, and the compass can continually compensate for the changes, ensuring you maintain accurate heading data throughout the voyage.

Locking the compass

Follow the steps below to lock the compass linearization.

From the Pilot set-up menu: **Homescreen > Settings > Autopilot > Pilot set-up.**

1. Select the **Compass Lock** toggle option so that it is enabled (Green)..

The compass linearization is now locked and automatic linearization will no longer be performed.

6.2 Autopilot control

Your MFD can be integrated with an Evolution autopilot system and act as the autopilot's controller. Please refer to the documentation supplied with your autopilot for details on installing and connecting your autopilot to your MFD.

Autopilot control from your MFD can be enabled and disabled from the **Autopilot** tab in the **Settings** menu: **Homescreen > Settings > Autopilot > Pilot control.**

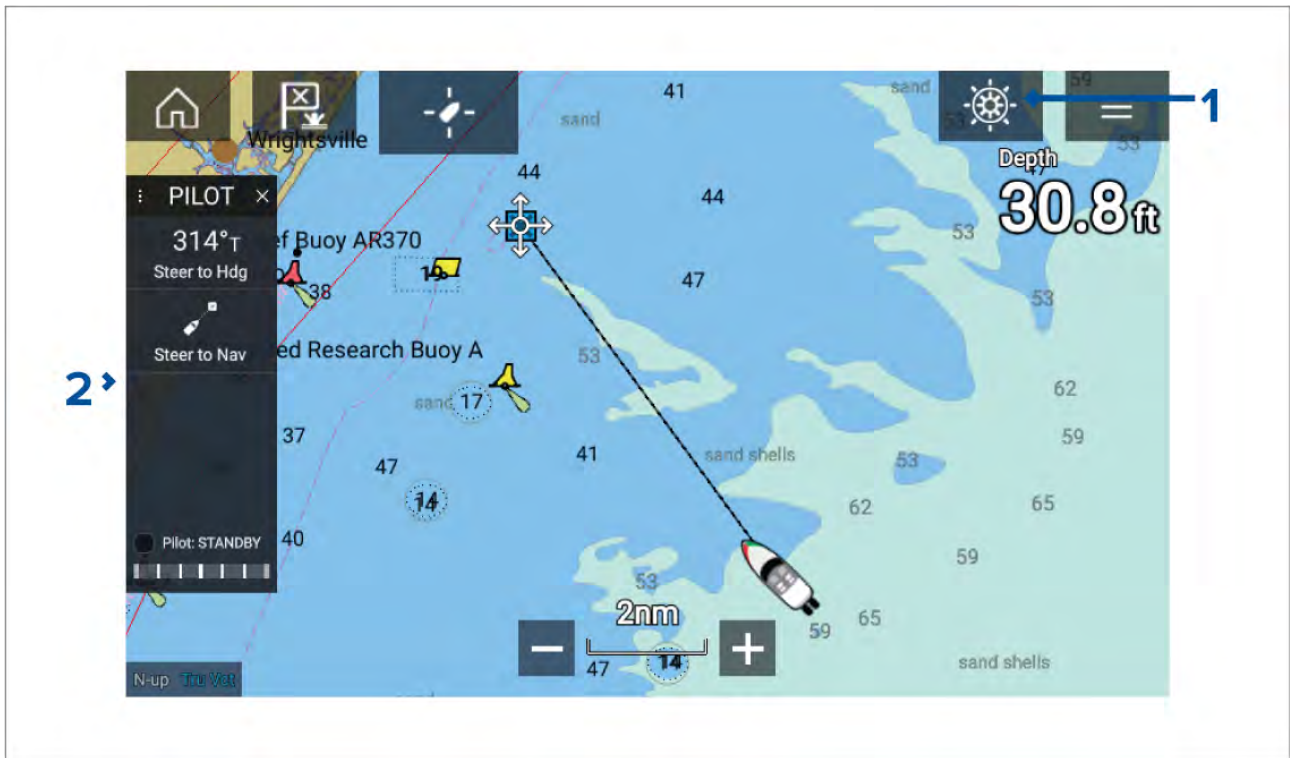

1. **Pilot icon** — With **Autopilot control** enabled, the Pilot icon is displayed onscreen; selecting the icon displays the Pilot sidebar. When the Autopilot is engaged the Pilot icon is replaced with the Disengage pilot icon.
2. **Pilot sidebar** — The Pilot sidebar provides controls and information relating to your autopilot system. With the Autopilot engaged the Pilot sidebar's content is expanded to provide further controls and information. The Pilot sidebar can be hidden by swiping the sidebar to the left. The sidebar can be displayed again by swiping from the left of the screen towards the center of the screen.

Engaging the autopilot — Locked heading

With Autopilot control enabled:

1. For Wheel and Tiller pilots, engage the mechanical drive by either engaging the wheel drive's clutch or attaching the pushrod onto the tiller pin.
2. Select the **Autopilot icon**.
The Pilot sidebar is displayed.
3. Select **Steer to Hdg**.
4. Select **Engage pilot**.

Engaging the autopilot — Navigation

With Autopilot control enabled:

1. For Wheel and Tiller pilots, engage the mechanical drive by either engaging the wheel drive's clutch or attaching the pushrod onto the tiller pin.
2. Initiate a Goto or Follow from the chart app.
3. Select the **Autopilot icon**.
The Pilot sidebar is displayed.
4. Select **Steer to Nav**.
5. Select either **Engage pilot** or if a cross track error exists then select **ALONG route leg** or **DIRECT from here**.

Selecting **ALONG route leg** will steer along the original track.

Selecting **DIRECT from here** will plot a new track from your current position to the destination.

Engaging and disengaging the autopilot - physical buttons

The process for engaging your autopilot using the physical buttons available on a RMK remote keypad or an Axiom Pro is shown below.

1. Press and hold the **Pilot** button to engage the autopilot in Locked heading mode.
2. Press the **Pilot** button again to disengage the autopilot.

Disengaging the autopilot

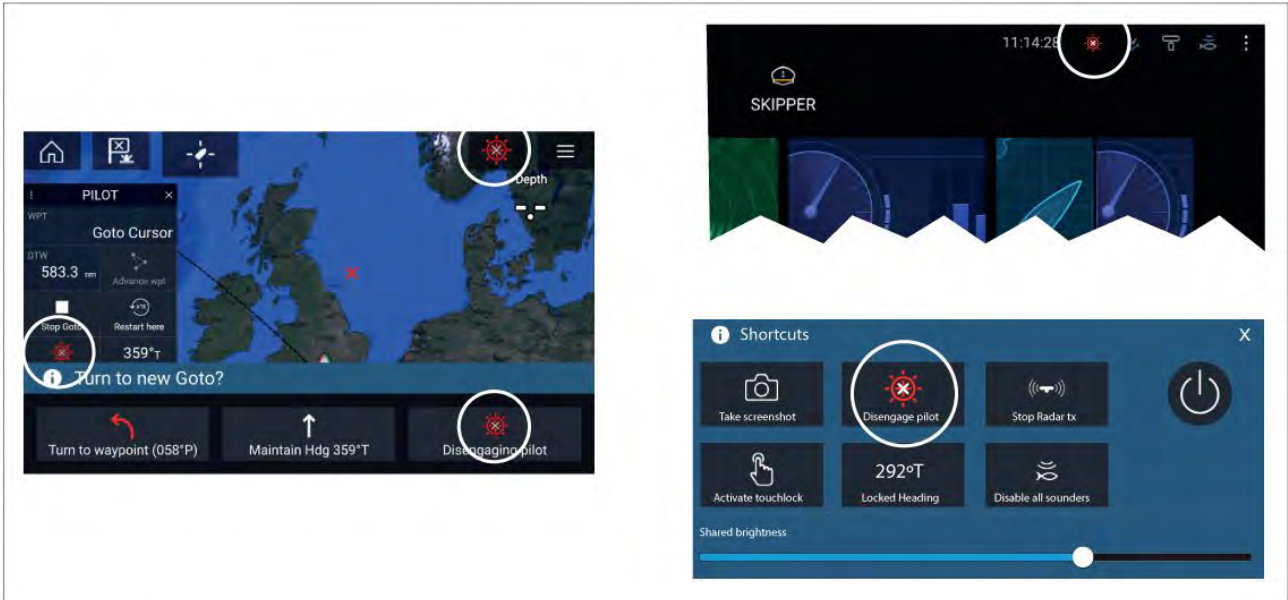

You can disengage your autopilot at any time by selecting the **Disengage pilot icon**.

The **Disengage pilot icon** is available in all apps. It is also available on the Pilot sidebar, in Pilot pop up messages, on the Homescreen and on the Shortcuts page.

6.3 Pilot sidebar

Depending on the state of your autopilot the following information and controls are available on the Pilot sidebar.

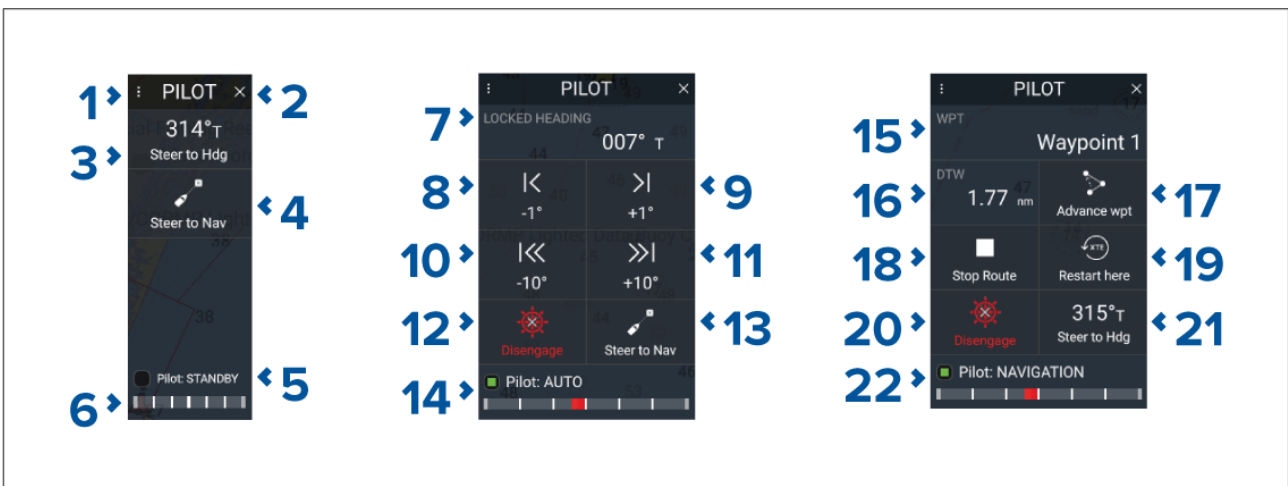

Note: The Pilot sidebar is controlled using the Touchscreen.

Pilot sidebar — Standby

1	Sidebar selection Enables you to switch between Pilot and Data sidebars.
2	Close Closes the Pilot sidebar.

3	Steer to Hdg Enables you to engage the autopilot in locked heading (Auto) mode.
4	Steer to Nav Enables you to engage the autopilot in Navigation (Track) mode.
5	Pilot status Provides the status of the autopilot.
6	Rudder bar Provides visual indication of rudder position.
7	Heading Displays your autopilot's current locked heading. Selecting displays the Locked Heading adjustment pop-over.
8	-1° Selecting will adjust your locked heading by minus 1 degree.
9	+1° Selecting will adjust your locked heading by plus 1 degree.
10	-10° Selecting will adjust your locked heading by minus 10 degrees.
11	+10° Selecting will adjust your locked heading by plus 10 degrees.
12	Disengage Selecting will disengage your autopilot.
13	Steer to Nav Selecting will engage your autopilot in Navigation mode.
14	Pilot state Displays the current state / mode of your autopilot.
15	Destination Displays your current destination.
16	User customizable data Displays user customizable data. Select to customize data.
17	Advance wpt Selecting will advance your destination to the next waypoint in the current route.
18	Stop Route / Stop Goto Selecting will stop current navigation.
19	Restart here Selecting will restart the cross track error (XTE) at your current location.
20	Disengage Selecting will disengage your autopilot.
21	Steer to Hdg Selecting will switch your autopilot to Locked heading mode.
22	Pilot state Displays the current state / mode of your autopilot.

6.4 Pilot pop-up

During active navigation, when you reach your current destination the Pilot pop-up is displayed.

Goto

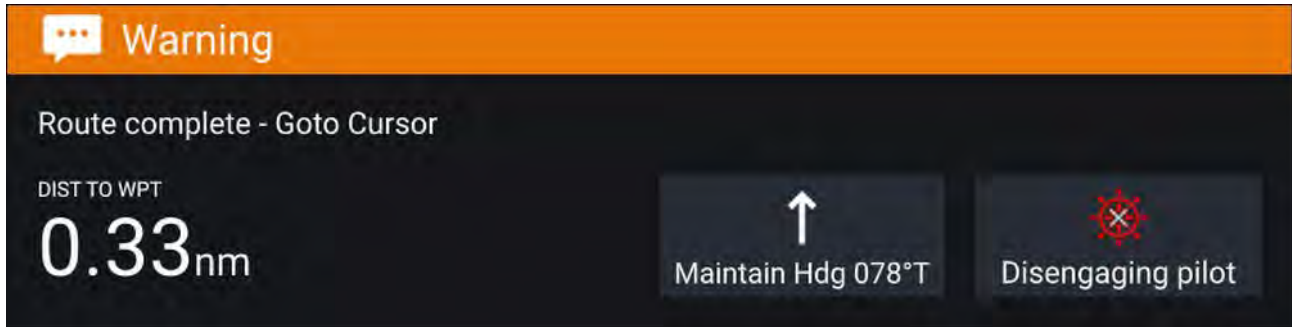

When performing a Goto the Pilot pop-up provides options to disengage the autopilot or to maintain the current course in Locked heading mode.

Follow

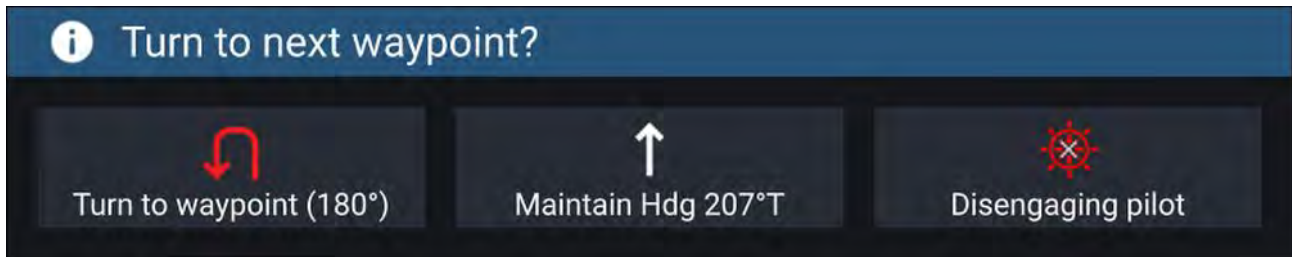

When following a Route the Pilot pop-up provides options to make the required turn to the next waypoint, disengage the autopilot or to maintain the current course in Locked heading mode.

6.5 Autopilot Control – Pilot set-up menu

Menu item and description	Options
Vessel hull type Selecting the hull type that is the closest match for your vessel provides optimum steering performance.	<ul style="list-style-type: none"> • Sail • Sail (slow turn) • Sail Catamaran • Power • Power (slow turn) • Power (fast turn)
Drive type Selecting the drive type that matches your vessel's drive will provide optimum drive performance.	List of drives compatible with your ACU.
Compass offset Adjust the Compass offset so that your autopilot's heading matches the ship's compass. The display of autopilot heading data requires a second networked MFD or pilot controller. Compass offset will be adjusted automatically during the Align compass to GPS procedure .	<ul style="list-style-type: none"> • -10° to +10° • 0° (default)
Speed input ⁽¹⁾ Selects the source for speed data.	<ul style="list-style-type: none"> • Auto (default) • Water speed (STW) • SOG • Default cruise speed
Cruise speed ⁽¹⁾ Set the Cruise speed value to your vessel's typical cruising speed.	<ul style="list-style-type: none"> • 4.0kts to 60.0kts

Menu item and description	Options
<p>Calibration lock The calibration lock is used to lock out specific calibration settings which if changed may require recommissioning of the autopilot system. If your system has been dealer installed then the lock may be turned on.</p>	<ul style="list-style-type: none"> • On (default) • Off
<p>Dockside wizard Dockside calibration must be carried out before using your autopilot for the first time. The Dockside wizard guides you through the dockside calibration process. The steps included in the dockside wizard are dependent on whether you have a rudder reference transducer fitted to your vessel.</p>	<ul style="list-style-type: none"> • Drive type • Rudder limit • Align rudder • Hard over time • Rudder drive check
<p>Restart compass Select to restart the compass linearization procedure.</p>	<ul style="list-style-type: none"> • Start • Cancel • Disengage pilot
<p>Compass lock Locks the compass linearization so that further automatic linearization is not performed.</p>	<ul style="list-style-type: none"> • On • Off (default)
<p>Align compass to GPS ⁽¹⁾ Follow the onscreen instructions to align your compass with your GPS heading. If your system has a GPS connected to your data network (SeaTalk, SeaTalkng or NMEA), the autopilot is tuned to the GPS heading while you steer to a known magnetic heading. This step provides a rough alignment and minimizes the amount of compass fine tuning required. As part of the align to GPS process, the autopilot system will compare the average heading with the average COG (Course Over Ground) value reported by the source of GPS data, and set an offset value so that the heading matches the COG value provided by the GPS.</p>	<ul style="list-style-type: none"> • Start • Cancel • Disengage pilot
<p>Pilot factory reset Resets your autopilot's settings to factory default values.</p>	<ul style="list-style-type: none"> • Yes • No
<p>CCU debug level ⁽¹⁾ Sets a debug value for troubleshooting purposes. The debug level should only be set when requested by Technical Support as part of a troubleshooting process.</p>	<ul style="list-style-type: none"> • 0 to 63
<p>ACU debug level ⁽¹⁾ Sets a debug value for troubleshooting purposes. The debug level should only be set when requested by Technical Support as part of a troubleshooting process.</p>	<ul style="list-style-type: none"> • 0 to 63
<p>Rudder damping ⁽¹⁾ Rudder damping is used to prevent the autopilot from "hunting" maneuvers. Always use the lowest acceptable value. For more information, refer to: p.109 – Rudder damping levels and deadband angles</p>	<ul style="list-style-type: none"> • 1 to 9 • 3 (default)
<p>Auto turn angle ⁽¹⁾ Determines the amount of course change when performing an auto turn.</p>	<ul style="list-style-type: none"> • 10° to 125° • 90° (default)
<p>Power steering ⁽³⁾ Determines the behavior of the Rotary or Joystick.</p>	<ul style="list-style-type: none"> • Off (default) • Proportional • Bang Bang
<p>Reverse rudder ref ⁽³⁾ Inverts the rudder reference display graphic.</p>	<ul style="list-style-type: none"> • On • Off

Menu item and description	Options
Motor phasing ⁽¹⁾ Switches the polarity of your drive motor. Use if your drive polarity is inverted.	<ul style="list-style-type: none"> • A • B
Rudder offset ⁽³⁾ Adjust to specify the rudder offset from amidships.	<ul style="list-style-type: none"> • -10° to +10° • 30° (default)
Rudder limit Specifies how far the rudder can move before hitting its end stops. The value should be set to approximately 5° less than your maximum rudder angle.	<ul style="list-style-type: none"> • 10° to 50° • 30° (default)
Hard over time Specifies the time it takes for the rudder to move from hard port to hard starboard or vice versa. The default value is determined by your Drive type selection.	<ul style="list-style-type: none"> • 1 to 100.0 seconds
Gybe inhibit ⁽²⁾ When set to Prevent Gybe the autopilot will prevent you from performing an Auto tack away from the wind.	<ul style="list-style-type: none"> • Allow Gybe • Prevent Gybe
Wind data type ⁽²⁾ Selects whether wind data is True or Apparent.	<ul style="list-style-type: none"> • Apparent • True
Wind shift alarm ⁽²⁾ Enables and disables the Wind shift alarm.	<ul style="list-style-type: none"> • On • Off

Note:

- (1) Option not available when **Calibration lock** is **On**.
- (2) Only available when Vessel hull type is set to a Sailing vessel.
- (3) Only available when a rudder reference transducer is connected.

6.6 Rudder damping levels and deadband angles

For autopilot systems which include a rudder angle reference sensor / transducer, rudder damping is used to prevent Evolution autopilot system over-activity, characterized by “hunting” maneuvers. A number of rudder damping levels are available to address this behavior. Rudder damping levels relate to “deadband angles”, and can be configured using your autopilot control head (e.g. p70s/p70Rs or MFD). A higher damping level is intended to eliminate pilot and helm over-activity.

Typically, the appropriate rudder damping level is the lowest acceptable value. However, it is important to be aware that the rudder damping scaling has been changed in recent versions of ACU units, which include newer processor and software versions (these units can be identified with an “A” appended to their SKU).

Important: The rudder damping levels can have a significant impact on your autopilot performance. If you are unsure as to how to adjust these settings to best suit your autopilot system, please refer to your dealer or Raymarine product support.

The following table lists the rudder damping levels and deadband angles that are available with both old and new versions of the ACU software:

Rudder damping level	Existing Deadband angle		New Deadband angle (ACU software version v3.11 onwards)
	ACU-100, 150, 200, 400	ACU-300	
1	0.1°	0.15°	0.1°
2	0.2°	0.30°	0.2°
3	0.3°	0.45°	0.3°
4	0.4°	0.60°	0.4°
5	0.5°	0.75°	0.7°
6	0.6°	0.9°	0.9°
7	0.7°	1.05°	1.1°
8	0.8°	1.20°	1.6°
9	0.9°	1.35°	2.2°

It's important to check the rudder damping level currently configured on your autopilot control head, to ensure it matches your needs. The rudder damping value should be increased one level at a time until the autopilot stops hunting.

Adjusting the Rudder Damping level

Use the following menu path to adjust the Rudder Damping level:

1. **Homescreen > Settings > Autopilot > Advanced settings > Rudder Damping.**

Chapter 7: Waypoints, Routes and Tracks

Chapter contents

- [7.1 Waypoints on page 112](#)
- [7.2 Routes on page 114](#)
- [7.3 Tracks on page 118](#)

7.1 Waypoints

Waypoints are used to mark specific locations or points of interest. Waypoints can be used in the Chart, Radar and Fishfinder apps. Your MFD can store up to 10,000 waypoints which can be sorted into up to 200 waypoint groups.

You can navigate to a waypoint by selecting **Goto** from the Waypoint's context menu.

Placing a waypoint

Example — Placing a waypoint in the Chart app

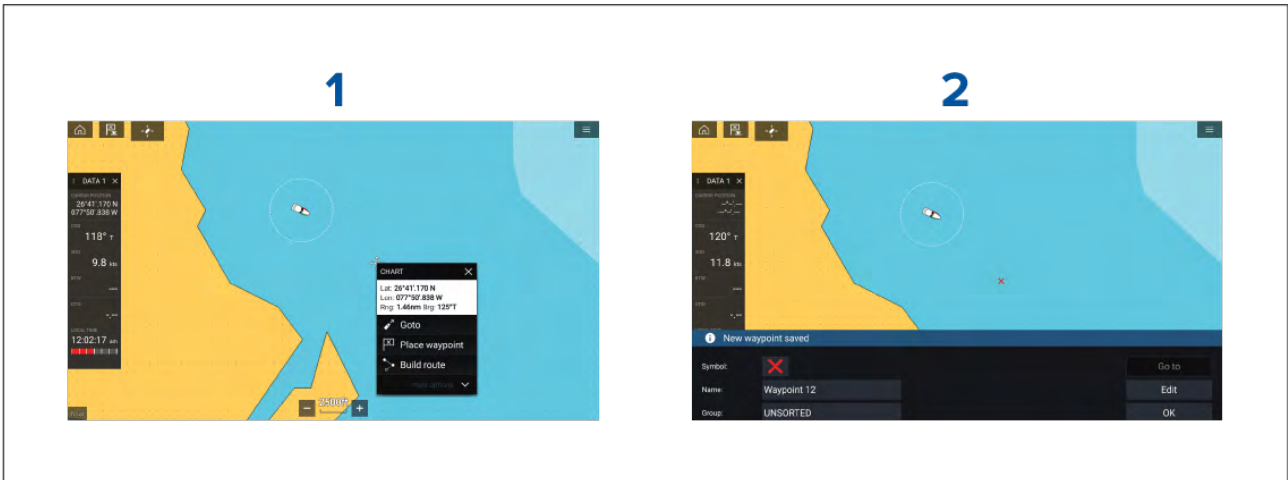

1. Select and hold on the desired location and select **Place waypoint** from the context menu..
2. Select **Edit** to edit the waypoint details, **Goto** to navigate to the Waypoint, or **OK** to return to normal operation.

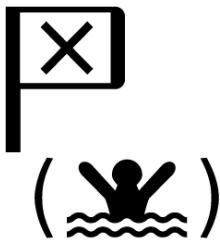

To place a waypoint at your vessel's current location press the Waypoint/MOB icon or physical button.

Placing a waypoint at a specified lat/long

You can place a waypoint at a specified latitude and longitude.

1. Select **New waypoint at lat/long** from the New page in the Chart app menu: **Menu > New > New waypoint at lat/long**
2. Enter the latitude and longitude for the waypoint.
3. Select **Save**.

Waypoint management

Waypoints are managed using the Waypoint list.

The Waypoint list can be accessed from the Homescreen and from the Chart app: **Homescreen > My data > Waypoints**, or **Chart app > Menu > Waypoints, routes, tracks > Waypoints**.

Waypoint list

The Waypoint list is sorted into groups. Selecting a group displays a list of all the waypoints included in that group. Selecting a waypoint displays the customizable details for that waypoint.



From the Waypoint list you can **Search** for a waypoint, Create a **New group**, Create a **New Waypoint** or **Delete** a waypoint group.

Selecting a Waypoint group from the list displays a list of all waypoints in that group.

Group lists



If the Waypoint list is accessed from the Chart app menu, the selected group or waypoint is displayed in a Chart pane on the right of the screen.

You can **Rename**, **Delete** or **Hide/Show** the group by selecting the Group name at the top of the list.

From the group list you can change the list sort order, Hide/Show the Waypoint group in the current Chart app instance or create a **New waypoint**.

Use the **Multi-edit** option to make the same change to multiple Waypoints (e.g. change symbol, delete waypoints or move to a different group).

Select a waypoint to view its details.

Waypoint details

Waypoint 4

Name: Waypoint 4 Delete

Symbol: Go to

Group: FISHING

Position: 26°40'.323 N 077°46'.672 W

Bearing: 079.9°T Range: 1.04nm

Water temp: -- Depth: --

Time: 12:41:25am Date: 05/18/2017

Comment: Good fishing

The details for the waypoint can be customized by selecting the relevant field. You can also **Delete** the waypoint, set a **Goto**, or **View on chart**.

7.2 Routes

Routes are used to plan your journey in advance. You can plan your journey directly on your MFD, or at home using software capable of exporting Waypoints and Routes in standard .gpx format, such as Raymarine's Voyage Planner software.

Routes consist of a number of waypoints. Your MFD can store up to 250 Routes, each Route consisting of up to 500 waypoints. The Route capacity limit is subject to your MFD's 10,000 Waypoint limit (for example, your MFD could store 20 Routes each containing 500 waypoints).

Creating a Route



1. Select and hold on the location for the first waypoint.
2. Select **Build route** from the context menu.
3. Select the location for the second waypoint.
The 2 waypoints will be joined by a line, creating the first leg of your route.
4. Select the location for subsequent waypoints.
5. Check your Route will be safe to follow, you can move the waypoints in your route by dragging them to a new location.
6. When your Route is complete select **Finish route build**.

Use Autorouting during route creation

Whilst building a route you can use Autorouting to automatically add a route leg to a route you have already started to create. The Autorouting features require compatible cartography.

1. Press and hold anywhere on screen and select either **Autoroute to wpt** or **Autoroute to here**.

*Selecting **Autoroute to wpt** will allow you to select a waypoint from your Waypoints list to include in your route, selecting **Autoroute to here** will create a route leg to the cursor's current position.*

Once an Autoroute leg has been added you can select **Finish route build** or add further manual or autoroute route legs.

Autoroute

Autoroute is available when using compatible cartography. Autoroute allows you to build a route automatically between a point on the chart and your vessel.

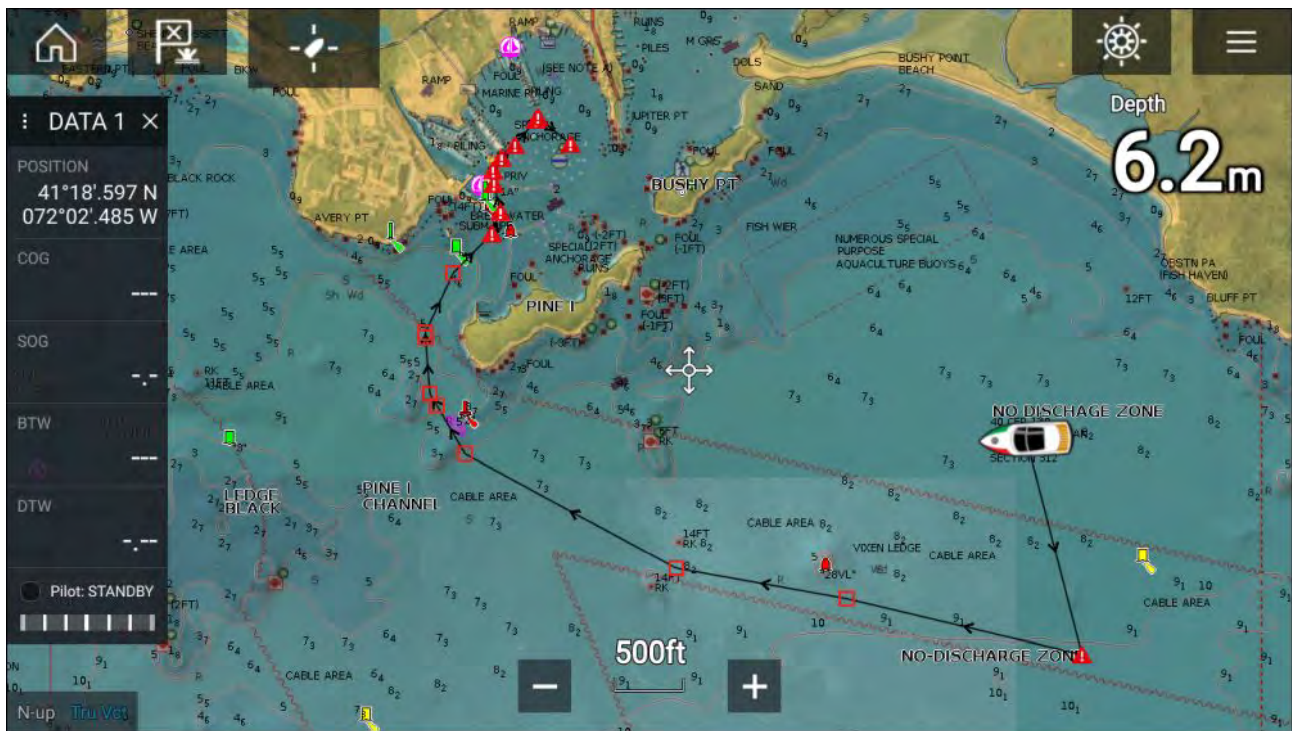

You can select any point on the Chart and from the Chart context menu select **Autoroute to here** or you can select **Autoroute to** from an existing waypoint's context menu to create a route automatically between your vessel and the chosen point.

The created route is generated by comparing data available on your cartography against the minimum safe distances specified in the **Boat details** menu: (**Homescreen > Settings > Boat details**).

Waypoints will not be placed in areas that conflict with your specified minimum safe distances. Caution symbols are used for waypoints that are near objects or restricted areas.

Never follow a route before checking each route leg is safe for your vessel.



Warning: Automatic route generation

- Do NOT rely on automatically generated routes to guarantee that the route is safe to navigate. You **MUST** review the suggested route carefully and where necessary edit the route before following it.
- If a waypoint within any automatically generated route is added or moved the Automatic route generation algorithm will NOT be used, extra care should be taken to ensure that the route leg and any moved waypoints are safe to navigate.

Caution: Easy Routing - Dredged areas

The C-MAP® Easy Routing feature will ignore some hazards in dredged areas. Easy Routing is intended for passage planning between harbors rather than within a harbor.



Warning: Traffic separation

Automatic route generation features do not adhere to the Traffic Separation Schemes identified in Rule 10 of the *International Regulations for Preventing Collisions at Sea 1972* as amended.

Raymarine® therefore recommends that you do NOT use Automatic route generation to create any part of a route which will cross traffic lanes or pass near to traffic separation lines. In these situations Automatic route generation **MUST** be switched Off and the route or route leg **MUST** be built manually, ensuring compliance to the rules laid out in the above regulations.



Warning: Minimum Safe Depth, Width and Height

Depending on cartography vendor, the minimum safe settings are used during automatic route generation, they are used to restrict created routes from entering areas that are not suitable for the vessel.

Minimum safe settings are user defined calculations. As these calculations are outside of Raymarine's control; Raymarine will not be held liable for any damage, physical or otherwise, resulting from the use of the automatic route generation feature or the **Minimum safe depth**, **Minimum safe width** or **Minimum safe height** settings.

Autoroute - compatible cartography vendors

The Autoroute feature is compatible with the following cartography vendor features.

- Navionics® Autorouting.
- Navionics® Dock-to-dock
- C-MAP® Easy Routing

Differences between automatic route generation functions

There are important differences between the way different vendors handle automatic route generation.

Depth clearances (Tidal height)

- Navionics® Autorouting and Dock-to-dock avoids shallow areas based on the user defined **Minimum safe depth** setting plus an additional Navionics® safety margin. It assumes the lowest tide level, normally Lowest Astronomical Tide (LAT). The tide can be lower than LAT due to atmospheric effects such as high air pressure, wind direction, etc.
- C-MAP® Easy Routing assumes that there will be some tide. The user must apply their own safety margin as appropriate to current conditions. Route legs that cross areas shallower than the user defined **Minimum safe depth** setting are marked with hazard waypoint symbols, it is critical that these legs are checked to ensure that there is sufficient tide to avoid the hazard.

Width & Height clearances

- Navionics® Autorouting and Dock-to-dock does not use the user defined **Minimum safe width** or **Minimum safe height** settings when generating routes. Objects with width / height constraints are marked with hazard waypoint symbols, it is critical that these legs are checked to ensure that there is sufficient clearance to avoid the hazard.
- C-MAP® Easy Routing uses the user defined **Minimum safe width** and **Minimum safe height** settings to determine if sufficient clearance is available. The user must apply their own safety margin as appropriate to current conditions. The Height datum must be checked, as it could be Mean High Water Springs (MHWS) or Highest Astronomical Tide (HAT). In both cases the tide can be higher than the datum due to atmospheric effects such as high air pressure, wind direction, etc.

Reviewing an automatically generated route

Before following any route you must ensure that it is safe to do so.

Upon Route completion:

1. Range in on each route leg and waypoint that make up the Route.
2. Check either side of the route leg and around the waypoint for any possible obstructions.

Obstructions can be charted objects or restricted areas. Routes generated automatically should use the caution waypoint symbol in areas where there are possible obstructions.

3. Where obstructions exist move the necessary waypoints so that the waypoint and route leg is no longer obstructed.

Importing a route

You can import routes created in standard gpx format.

1. Save your route to a memory card.
2. Insert the memory card into your MFD.
3. Select Import from card from the Import/export page: **Homescreen > My data > Import/export > Import from card.**
4. Locate and select the gpx file that contains your Route.
The Route will be imported to your MFD.

Route management

Routes are managed using the Route list.

The Route list can be accessed from the Homescreen and from the Chart app: **Homescreen > My data > Routes**, or **Chart app > Menu > Waypoints, routes, tracks > Routes**.

If the Route list is accessed from the Chart app menu, then the selected route is displayed in a Chart pane on the right of the screen.

Route list

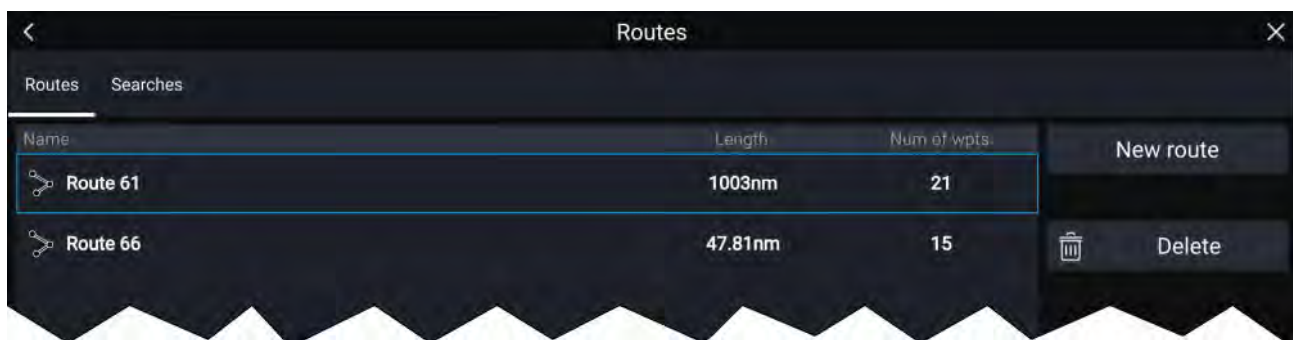

From the route list you can **Delete** routes or create a **New route** using existing waypoints.

To view a route plan, select a route and choose **View route plan**.

Route plan

The route plan displays a list of all waypoints in the route and when accessed from the Chart app also includes a Chart pane showing the route's location.

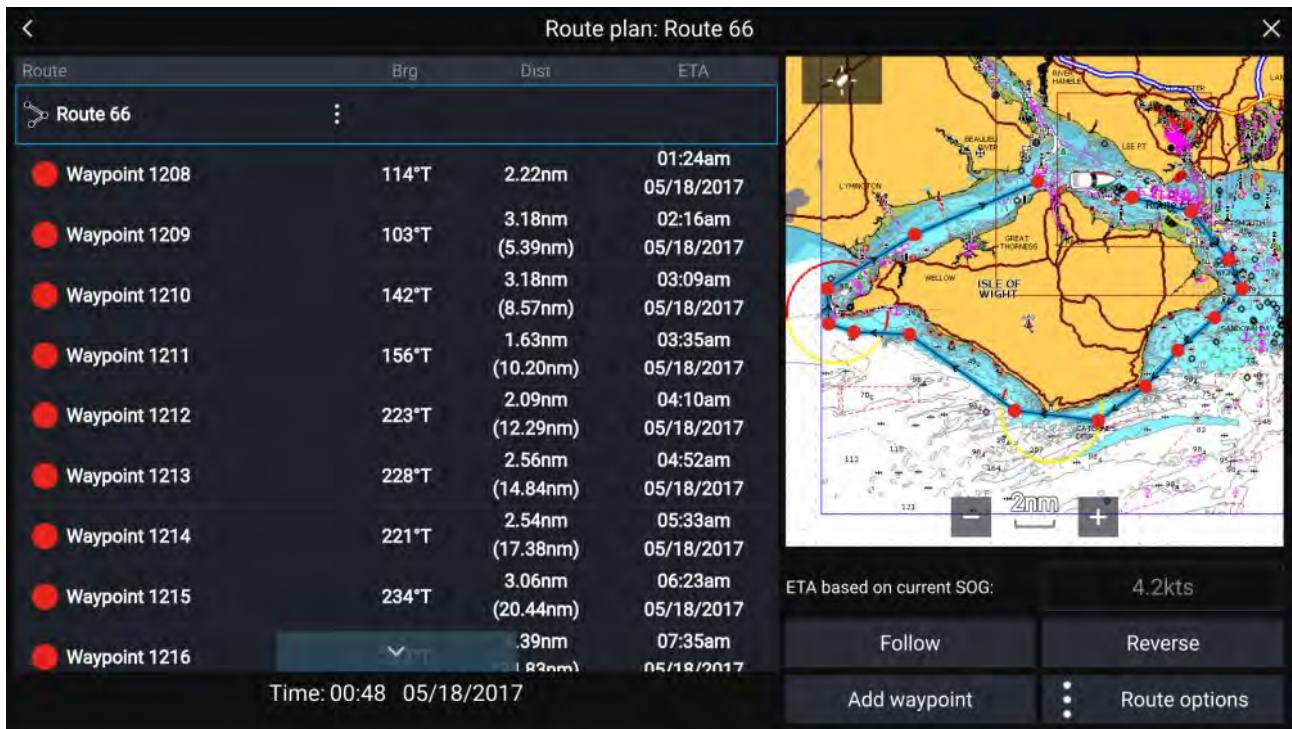

From the Route plan you can:

- navigate the route by selecting **Follow**
- change the route direction by selecting **Reverse**
- add an existing waypoint to the route by selecting **Add waypoint**
- change route options by selecting **Route options**

By selecting a waypoint from the route plan you can change the waypoint order by moving the waypoint up and down the list. You can also remove the waypoint from the list, delete the waypoint, edit the waypoint details or start the Route follow from any waypoint in the route.

Route options

Rename route	Give the route a name.
Color	Change the color of the route, as displayed in the Chart app.
Time	Switch the time between ETA (Estimated Time of Arrival) and TTG (Time To Go).
Speed	Switch the speed between Actual (SOG) and Planned . When the speed is set to Planned you can select a desired speed for navigating the route.
Hide/show on chart	Choose whether the Route should be displayed in the Chart app or not.
Export	Export the route to a memory card.
Delete route	Delete the route.

7.3 Tracks

Tracks are used to record where you have been. Tracks are made up of track points that are created at regular time or distance intervals. You can store up to 15 tracks on your display, each track can contain up to 10,000 points.

Tracks can be converted into routes so that they can be followed.

Creating a track

You can record your vessel's journey using Tracks.

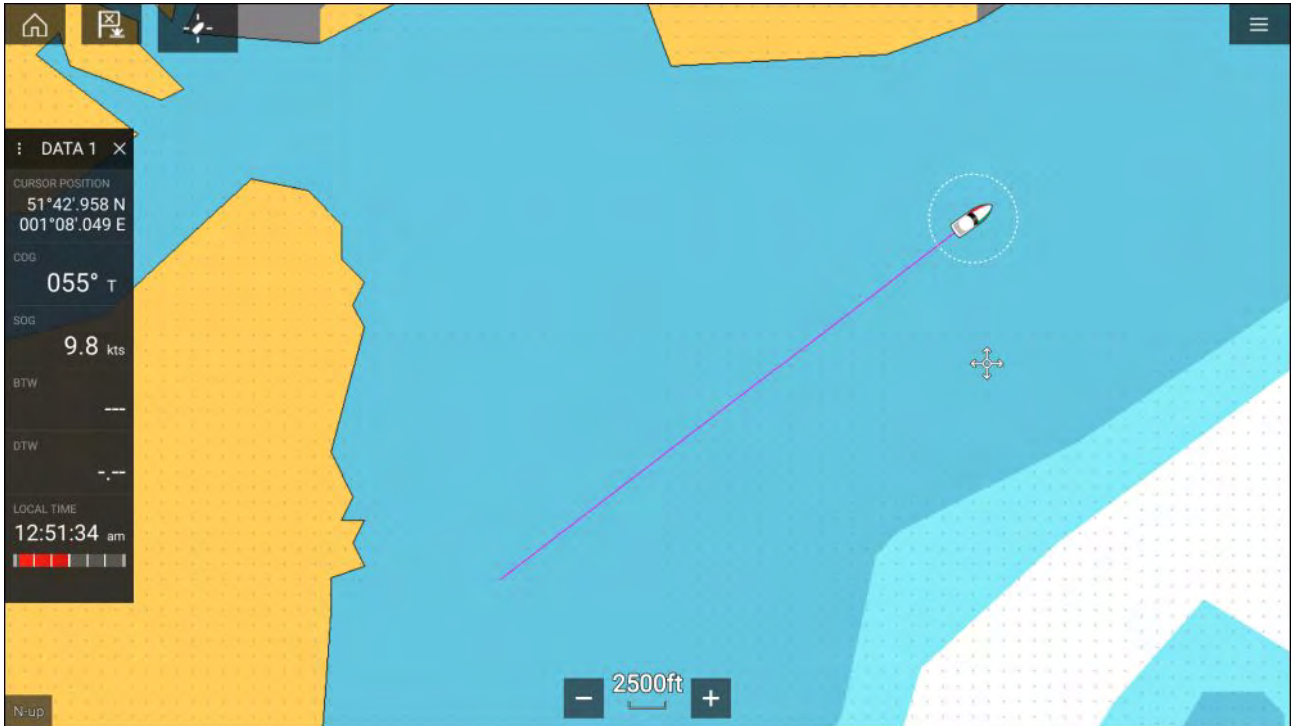

1. Select and hold on your vessel icon to display the vessel pop-over options.
2. Select **Start track**.
Your vessel's journey will now be recorded.
3. Select **Stop track** from the pop-over options when you have completed your track.
4. Select **Save** to save the track or **Delete** to remove the track.

You can also start a new track recording at anytime from the Chart menu: **Menu > New > Start a new track**. When using the Chart menu to start a track, if a track is already recording then it will be saved before the new track is started. Once a Track is saved it can be converted to a Route so that the same passage may be followed again at a later date.

Converting a track to a route

From the Track list: **Menu > Waypoints, routes, tracks > Tracks**.

1. Select a track.
2. Select **Create route from track** from the pop-over options.
3. Select **OK**.

Track management

Tracks are managed using the Track list.

The Track list can be accessed from the Homescreen and from the Chart app: **Homescreen > My data > Tracks**, or **Chart app > Menu > Waypoints, routes, tracks > Tracks**.

If the Track list is accessed from the Chart app menu, then the selected track is displayed in a Chart pane on the right of the screen.

Track list



From the track list you can Start or Stop tracks recording, **Delete** a track or choose how tracks are recorded.

Track interval

The track interval determines the time period or distance between track points when recording a track. You can choose whether to record track points by Time, by Distance or set to Auto.

- In **Auto** the track interval is set automatically to minimize the track points used whilst maintaining the actual path taken.
- When set to **Time**, you can choose a specified time period between track points.
- When set to **Distance** you can choose a specified distance between track points.

Customize tracks

From the Track pop-over options you can:

- rename a track
- change track color
- create a route from a track
- delete a track
- hide/show the track in the Chart app.

Chapter 8: Chart app

Chapter contents

- 8.1 Chart app overview on page 122
- 8.2 Cartography overview on page 129
- 8.3 Navigation on page 138
- 8.4 Depths and contours on page 139
- 8.5 Target tracking on page 142
- 8.6 Collision avoidance on page 151
- 8.7 Target intercept on page 163
- 8.8 Tides mode on page 164
- 8.9 RealBathy™ on page 170
- 8.10 Find nearest on page 171
- 8.11 Measure on page 173
- 8.12 SAR (Search and Rescue) patterns on page 175
- 8.13 Laylines on page 184
- 8.14 Race Start Line (SmartStart) and Race Timer on page 189
- 8.15 ClearCruise™ Augmented Reality on page 194
- 8.16 UAV Chart integration on page 196
- 8.17 SonarChart™ Live on page 197
- 8.18 Chart settings menu on page 198

8.1 Chart app overview

The Chart app displays a representation of your vessel in relation to land masses and other charted objects, which enables you to plan and navigate to your desired destination. The Chart app requires a GNSS (GPS) position fix in order to display your vessel at the correct location on a world map.

For each instance of the Chart app you can select which electronic cartography you want to use. The selection will persist over a power cycle.

The Chart app can be displayed in both fullscreen and splitscreen app pages. App pages may consist of up to 4 instances of the Chart app.



1	Waypoint Use waypoints to mark specific locations or points of interest.	2	Track You can record the passage your vessel takes using Tracks.
3	Vessel icon This icon represents your vessel, only displayed when a GNSS (GPS) position fix is available. The icon will be a black dot if no Heading is available).	4	Wind indicator Provides indication of wind direction and speed (Wind transducer required).
5	Route You can plan your route in advance by creating a Route using Waypoints to mark each route leg.	6	Destination waypoint During a Goto, this is the current destination waypoint.
7	Heading line If Heading data is available, a Heading vector for your vessel can be displayed.	8	COG line If COG data is available, you can display a COG vector for your vessel.

9	Tide indicator Provides tide Set and Drift indicators. Requires the following data: COG, Heading, SOG, and STW (Speed Through Water).	10	Chart range Identifies the scale for the displayed Chart range.
11	Range rings Provides a distance indication around your vessel at set intervals.	12	Sidebar The Sidebar contains system data that can be viewed in all apps.

Chart app controls







Icon	Description	Action
	Home icon	Takes you to the Homescreen
	Waypoint / MOB	Place waypoint / hold down to activate Man overboard (MOB) alarm
	Pilot icon	Opens and closes the Pilot Sidebar
	Menu icon	Opens the app menu
	Find vessel	Centers your vessel onscreen.
	Range In	Decreases the range/distance displayed onscreen.
	Range Out	Increases the range/distance displayed onscreen.

Chart ranging and panning

You can change the range displayed in the Chart app using the onscreen Range controls or by using the pinch-to-zoom multi-touch gesture.

You can pan the chart area by swiping your finger across the chart.

Chart app context menu

Context menus provide context sensitive menu options.

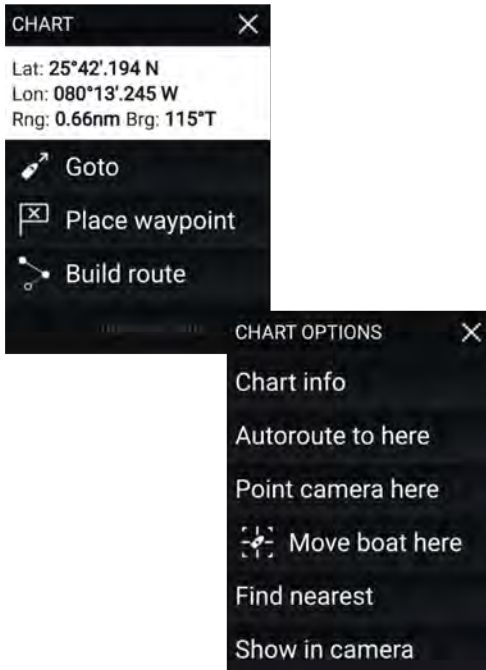

- Context menus are accessed in the Chart app by pressing and holding on a location or object.
- The context menu provides Latitude, longitude, range and bearing details for the selected location or object.
- The context menu provides quick access to relevant settings or features.
- Select **More options** to display further options.

Note:

The **Move boat here** option is only available in Demo/simulator mode.

Selecting a chart card

You can use LightHouse™ charts and compatible Navionics and C-MAP electronic charts. The electronic chart cards must be inserted into the MFD's MicroSD card reader (or the card reader of an MFD on the same network).

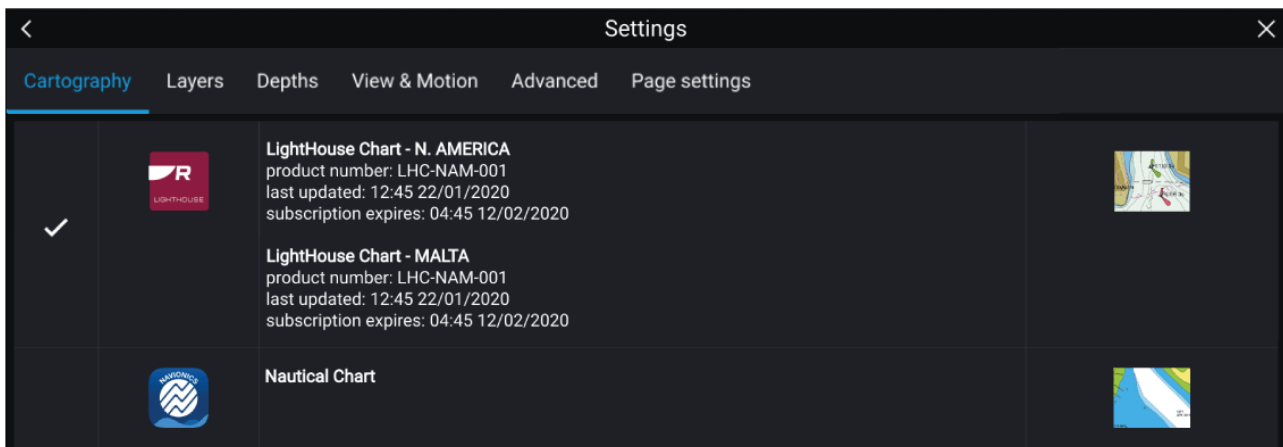

From the Chart app menu:

1. Select the **Settings** icon.
2. Select the cartography that you want to use from the Cartography tab.

You may choose a different chart for each instance of the Chart app, accessed from the Homescreen. Cartography selection will persist until changed.

Note:

If no chart cards are detected on your MFD network the **Chart app** will default to Lighthouse Chart cartography.

Chart modes

The Chart app provides preset modes that can be used to quickly set up the Chart app for your intended use.

To change Chart mode select the required mode from the app menu.



SIMPLE

In Simple mode, chart detail is suppressed to provide a clearer, simpler view for navigation and only navigation related menu options are available. Settings changes are not saved.



DETAILED

Detailed is the default mode. Full chart detail and menu options are available. Settings changes are saved to the user profile in use.



FISHING CHART

Fishing mode optimizes the Chart app for Fishing and if supported by your selected cartography, displays more detailed contour lines. Full menu options are available. Settings changes are saved to the user profile in use.



WEATHER

Weather mode is available when the MFD is connected to a compatible Weather receiver (SR150).

Weather mode allows you to overlay weather data directly on the chart and view animated weather graphics or read weather reports. Only Weather related menu options are available. Settings changes are saved to the user profile in use.

For further details on Weather mode refer to: [Chapter 10 Weather mode](#)



TIDES

In Tides mode, Tide Station and Current Station icons are replaced with graphics representing Tide and Current conditions. Animation controls are displayed that enable playback of Tide and Current predictions over a 24 hour period.

Tides mode also suppresses chart detail, to enhance the Tide and Current graphics and enables own vessel Tide vector graphics.



RACING

Racing mode optimizes the Chart app for Race Sailing.

Racing mode is available when the MFD is setup with Sailing as the boat activity.

In Racing mode, Race Start Line and Race Timer options become available from the menu, allowing you to create a start line and countdown timer which can help optimize your racing start.

Vessel details

The Vessel details pop-over provides access to vessel-related settings.

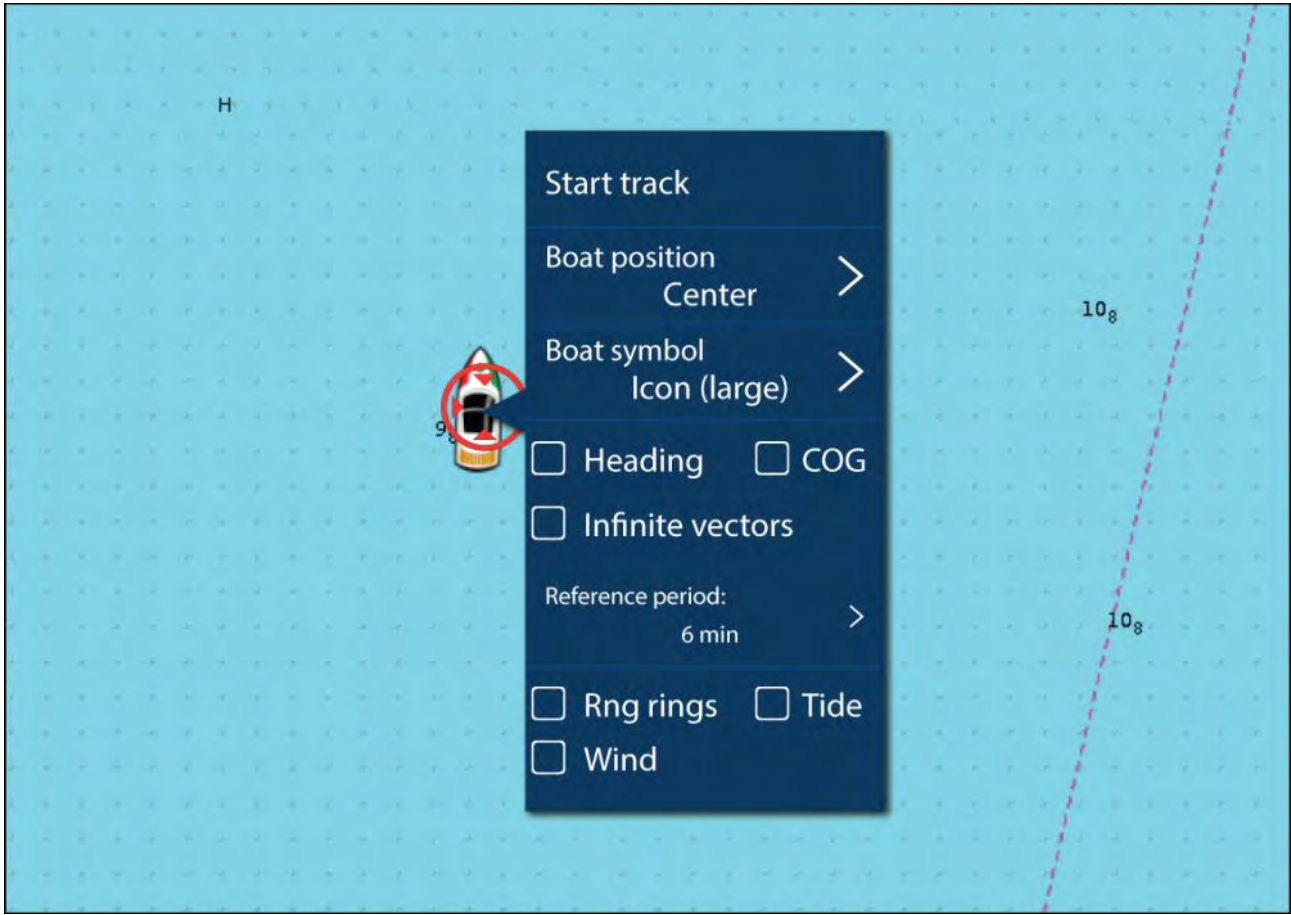

From the Vessel details pop-over you can:

- start/stop a track.
- offset the position of the vessel symbol.
- change the symbol used to represent your vessel.
- set the length of vessel vectors.
- show / hide Heading and COG vectors.
- show / hide Range Rings.
- show / hide Tide and Wind graphics.

Note:

In **Simple mode**, the only option available is Start/stop track.

Object selection and information

Charted objects, available on your cartography can be selected and object information can be viewed.



When you select an object the cursor will change to the Object cursor.

Cursor info boxes enabled



If the Cursor info box setting is enabled then when an object is selected an information pop-up is displayed. Selecting the pop-up will display a full screen information page.

The **Cursor info boxes** setting is accessed from the Advanced setting tab: **Menu > Settings > Advanced > Cursor info boxes**:

Full chart information

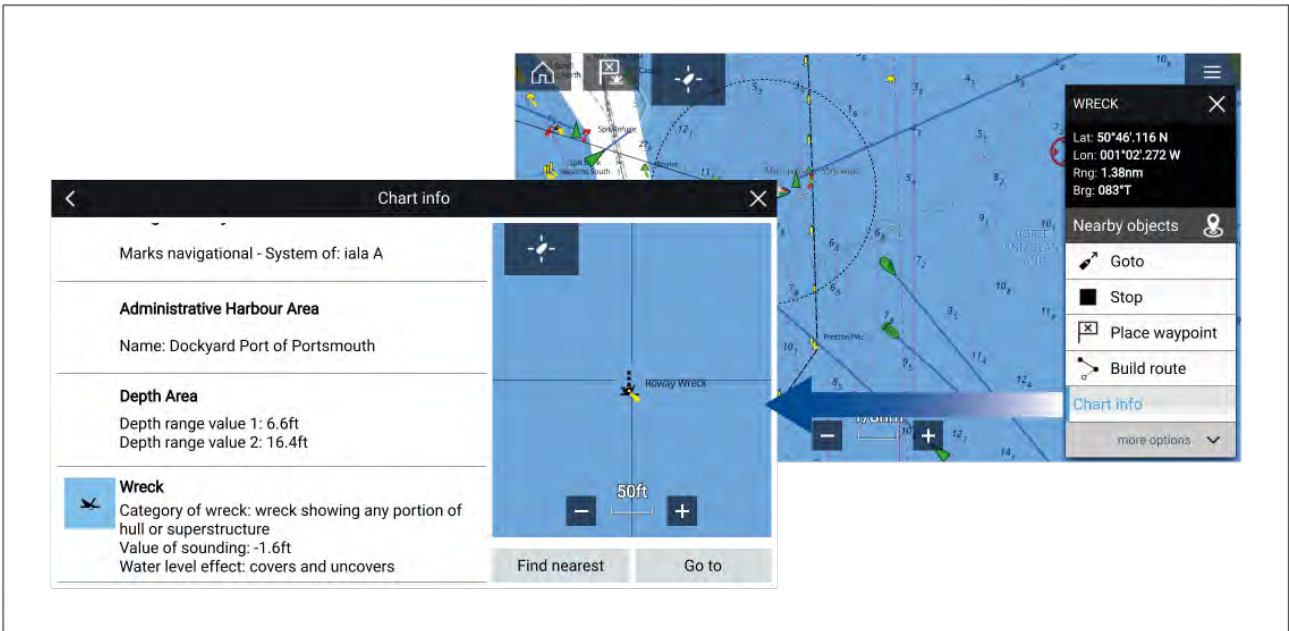

Selecting and holding on the object will display the object context menu.

Selecting **Chart info** will display the chart information page.

Layers

Layers are additional data views that can be overlaid (superimposed) on the Chart app. Types of layer include: aerial photographs, AIS targets, Radar image, range rings, tide graphs, weather Radar and crowd-sourced content.

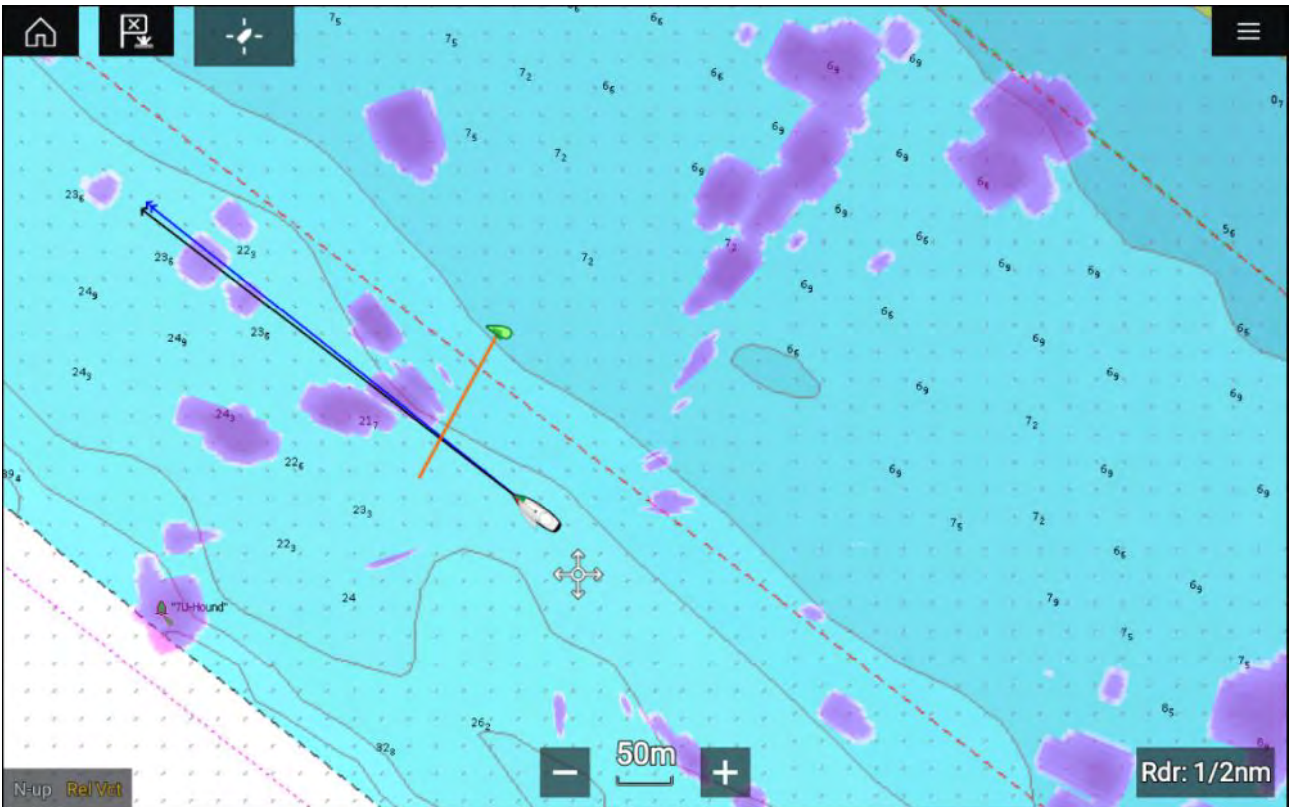

The Layers tab in the Chart app Settings menu provides controls for the Chart layers: **Menu** > **Settings** > **Layers**.

View and motion

The view and motion tab allows you to control how the chart is displayed in relation to your vessel.

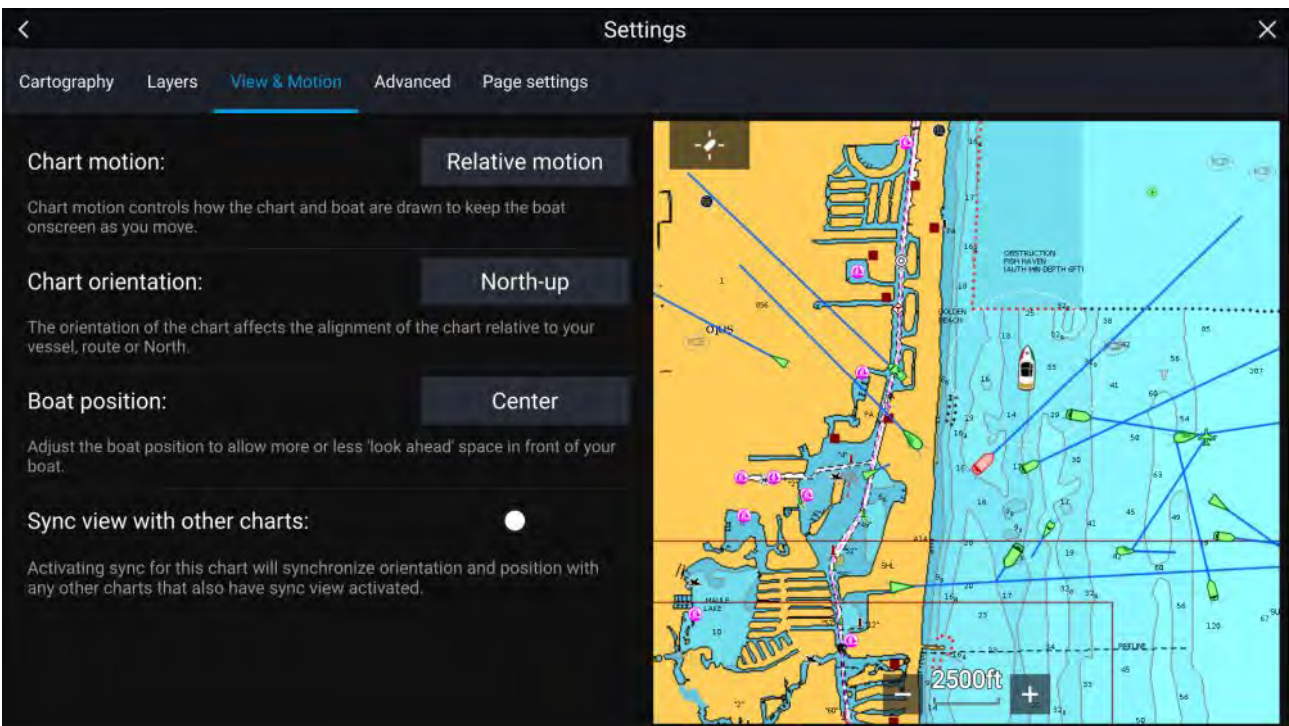

Chart motion

Chart motion controls how the chart and boat are drawn to keep the boat onscreen as you move.

Chart orientation

The orientation of the chart affects the alignment of the chart relative to your vessel, route or North.

Boat position

Adjust the boat position to allow more or less 'look ahead' space in front of your boat.

Sync view with other charts

Synchronize the orientation and position of all charts that have this setting enabled.

Camera tracking

When connected to a compatible Pan and Tilt Thermal camera you can track targets or point your camera at a specific target or area.

2 options are available for camera tracking:

- **Point camera here** — Points the camera at a specific point onscreen, the camera will remain pointed at this area regardless of your own vessel's course.
- **Track with camera** — Tracks a selected target regardless of your own vessel's or target's course.

Camera tracking options are available from the Context menu in the Chart and Radar apps: **Context menu > more options > Point camera here**, or **Context menu > more options > Track with camera**.

Automatic tracking

You can use the Camera app settings to configure automatic tracking for AIS, Radar and MoB targets:

Camera app > Menu > Settings > Camera motion > AUTO TRACKING

8.2 Cartography overview

The Chart app includes a basic world base map. To use the Chart app for navigation purposes, compatible, detailed Electronic Navigational Charts (ENC) or Raster Navigational Charts (RNC) are required.

- **Raster Navigational Chart (RNC)** — A Raster chart is a digital image of a paper chart and therefore the available information is limited to the information available on the paper equivalent.
- **Electronic Navigational Chart (ENC)** — ENCs are Vector based charts and include information that is not available on paper or Raster charts. Objects and features on Vector charts can be selected to obtain databased information that otherwise would not be readily available. Object and features can also be enabled and disabled or customized.

Note:

- The level of detail and features available on charts is dependent on vendor, chart type, subscription level and geographic region. Prior to purchasing charts check the vendor's website to establish what level of detail is available on the charts you want to purchase.
- The information relating to available chart detail and settings in this manual should be treated as guidance only as it is subject to change that is not under Raymarine's control.

The Chart app range scale will also effect the level of detail shown onscreen. Generally more detail is available at lower ranges. The chart scale in use is indicated by the scale indicator, the value displayed is the distance that the line represents across the screen.

You can remove and insert chart cards at any time. The chart screen is automatically redrawn when the system detects that a compatible chart card has been inserted or removed.

Different cartography types can be viewed simultaneously using an app page that includes multiple instances of the Chart app.

Supported charts

MFDs running the LightHouse 3 operating system can utilize the charts from the vendors listed below.



1. Next generation LightHouse™ charts (From LightHouse™ 3 V3.12 or greater).
2. Retired LightHouse™ vector, raster and NC2 charts (From LightHouse™ 3 V3.1 or greater).
3. S-63 encrypted charts (From LightHouse™ 3 V3.13 or greater).
4. Navionics charts (From LightHouse™ 3 V3.1 or greater).
5. C-Map (From LightHouse™ 3 V3.2 or greater).

Refer to the Raymarine website for the latest list of supported chart cards: www.raymarine.com/marine-charts/

To check the current availability of Navionics chart cards and types, please visit www.navionics.com or www.navionics.it.

To check the current availability of C-MAP® chart cards and types, please visit: www.c-map.com.

3rd party raster charts

Raster navigational charts from the 3rd party vendors listed below are supported.

Note:

Raster charts are created by scanning paper charts, each segment of the paper chart is turned into a digital image. The detail available on raster charts is limited to the detail on the paper chart it was created from. Raster charts do not offer dynamic content that is typically available on vector based electronic charts.

- **Standard mapping** — USA only.(For details visit: <https://www.standardmap.com/>)
- **CMOR Mapping** — USA only.(For details visit: <https://www.cmormapping.com/>)
- **Strike Lines Charts** — USA only.(For details visit: <https://strikelines.com/>)

Note:

For assistance using these charts refer to the chart vendor.

Caution: Care of chart and memory cards

To avoid irreparable damage to and / or loss of data from chart and memory cards:

- Ensure that chart and memory cards are fitted the correct way around. DO NOT try to force a card into position.
- DO NOT use a metallic instrument such as a screwdriver or pliers to insert or remove a chart or memory card.
- Ensure correct memory card ejection procedure is carried out before removing the chart or memory card from the card reader.

LightHouse charts

LightHouse™ charts is the brand name for Raymarine's electronic navigational charts. LightHouse™ charts can include a premium subscription which adds new and enhanced features.

Note:

Legacy LightHouse™ Vector, Raster and NC2 charts have now been discontinued and can no longer be downloaded or updated.

New LightHouse™ charts come with a free 1 year subscription to LightHouse™ Premium. The premium subscription unlocks data-rich points of interest (POI), high-resolution satellite aerial overlays and regular chart updates. After the free subscription ends the premium features can be continued for an annual fee.

LightHouse™ charts can be purchased from Raymarine dealers, as either a pre-loaded chart card or a blank chart card that includes a voucher that can be redeemed from the chart store.

To find out more about available regions and latest features visit the LightHouse™ charts store: <https://chartstore.raymarine.com/lighthouse-charts>

LightHouse Chart Store

LightHouse™ charts can be purchased from the LightHouse™ Chart Store, which can be accessed from a personal computer (PC) or from a mobile device via the RayConnect app.

You must have a Chart Store account and be logged in to the account before you can purchase charts in the Chart Store. This account can be created during the checkout process if required.

Pre-loaded LightHouse Chart Cards

LightHouse™ charts are also available pre-loaded on MicroSD cards. Simply insert the card into your MFD's card reader to start using.

Note:

New regions are added all the time, check with your local Raymarine dealer for the latest available regions.

- **R70794** — LightHouse™ Charts Preloaded North America.
- **R70794-AUS** — LightHouse™ Charts Preloaded Australia.
- **R70794-DEN** — LightHouse™ Charts Preloaded North Denmark
- **R70794-FIN** — LightHouse™ Charts Preloaded Finland.
- **R70794-FRA** — LightHouse™ Charts Preloaded France.
- **R70794-GER** — LightHouse™ Charts Preloaded Germany.
- **R70794-IGB** — LightHouse™ Charts Preloaded Ireland & Great Britain.

- **R70794–ITA** — LightHouse™ Charts Preloaded Italy.
- **R70794–NED** — LightHouse™ Charts Preloaded Netherlands.
- **R70794–NOR** — LightHouse™ Charts Preloaded Norway.
- **R70794–SWE** — LightHouse™ Charts Preloaded Sweden.
- **R70795** — Blank 32 GB download chart card with voucher code for any 2 regions.
- **R70838** — Blank 32 GB MicroSD card for LightHouse™ Charts.

Redeeming chart voucher

If you have purchased a download chart card with a voucher code then the voucher is redeemed from the LightHouse™ chart store.

1. Go to the LightHouse™ chart store: <https://chartstore.raymarine.com/lighthouse-charts>
2. Click **Redeem**.
3. Create a new account, or login to your existing account.
4. Enter your voucher code and click **Submit**.
5. Click **View charts** from the voucher accepted page.
6. Select the required region.
7. If your voucher entitles you to a second region click **Pick 2nd chart** and then select your second region.
8. Click **Done**.

Your selected region(s) will now be available in **MY CHARTS**.

Downloading charts from My Charts

Once redeemed charts can be downloaded from the MY Charts area of the LightHouse™ charts store.

1. Log in to your account.
2. Go to the **MY CHARTS** area.
3. Expand the Download options for the region(s) you want to download.
4. If updates are available click **Get latest data**.
5. If you have a valid Premium subscription add the **Streets & POI** and **Aerial photos** that you want to include.

*When adding **Streets & Points of Interest** and **Aerial photos** you can create up to 5 area boxes for each feature per purchased region. Follow the onscreen instructions to define each area of coverage.*

6. Click **Download**.
7. If you have more than 1 region you can group them together by selecting the relevant grouping option.

Grouping allows you to minimize download file size, by grouping up to 3 regions, from the same continent together.

8. Check the SD card requirements.

Important:

A blank chart card purchased from a Raymarine dealer will already be in the correct format.

9. Click **CONTINUE**.
10. Check unique ID file.

Important:

A blank chart card purchased from a Raymarine dealer will already include the unique ID file.

11. Click **CONTINUE**.
12. Check 'LightHouse_charts' folder

Important:

A blank chart card purchased from a Raymarine dealer will already include the 'Lighthouse_charts' folder.

13. Click **CONTINUE**.
14. Click **Browse to file** and locate the Lighthouse_id.txt file in the root directory of the chart card.
15. Click **CONTINUE**.

The download package will now be prepared and downloaded to your computer.

Note:

- Depending on files size and connection speed the package preparation and download may take some time, click **receive email notification** to get an email when the package is ready to be downloaded.
- If the download does not start automatically once the package has been prepared click **Download**.

16. Locate the downloaded file and copy to the Lighthouse_charts folder on your SD card.

Important:

Ensure that the folder contains only 1 file.

17. The memory card can now be inserted into your MFD.

S-63 Encrypted Charts

S-63 is an International Hydrographic Organization (IHO) standard for encrypting, securing and compressing electronic navigational chart (ENC) data. When correctly configured with a valid S-63 MFD activation file your MFD can utilize S-63 Encrypted Charts.

Advantages of using S-63 encrypted charts:

- Assured authenticity of chart data.
- Regular updates.

For more information refer to: <https://iho.int/en/>

S-63 Encrypted Charts installation process

Unlike electronic cartography from other vendors S-63 Encrypted Charts require an installation process to be carried out.

Note:

The recommended installation process requires up to 3 memory cards and that your MFD has more than 1 card reader slot available. For MFDs that have only 1 internal card reader slot an external card reader such as the RCR-SDUSB or RCR-2 is required.

1. MFD hardware activation. Refer to: [Obtaining an S-63 MFD activation file](#)
2. Copy user permit(s) file from MFD. Refer to: [Copying user permit file\(s\) to memory card](#)
3. Purchase and download charts (requires user permit file). Refer to: [Purchasing S-63 Encrypted Charts](#)
4. Install base cell files and cell permits file. Refer to: [Installing base cells and cell permits](#)
5. Install Cumulative update files and if received, new cell permits file. Refer to: [Installing cumulative updates](#)

Important:

- The memory card the charts are installed on must be represent in the MFD's card reader for the installed charts to be used.
- After installation it is recommended that the memory cards containing the base cells and cumulative updates are kept onboard your vessel so that if the need arises they can be reinstalled easily.

Obtaining an S-63 MFD activation file

An S-63 MFD activation file must be installed on your MFD to display and enable the use of S-63 Encrypted Charts on your MFD. Without the S-63 MFD activation file installed S-63 chart selection and related settings will not be available.

Note:

An S-63 MFD activation file will be required for each MFD you want to be able to view S-63 encrypted charts on. S-63 encrypted charts are not shared with other MFD's on the same network.

1. Identify your MFD's product name, product number and serial number.

The required information can be found on the **Getting started** tab of the Settings menu: **Homescreen > Settings > Getting started.**, or from the product label.

Example

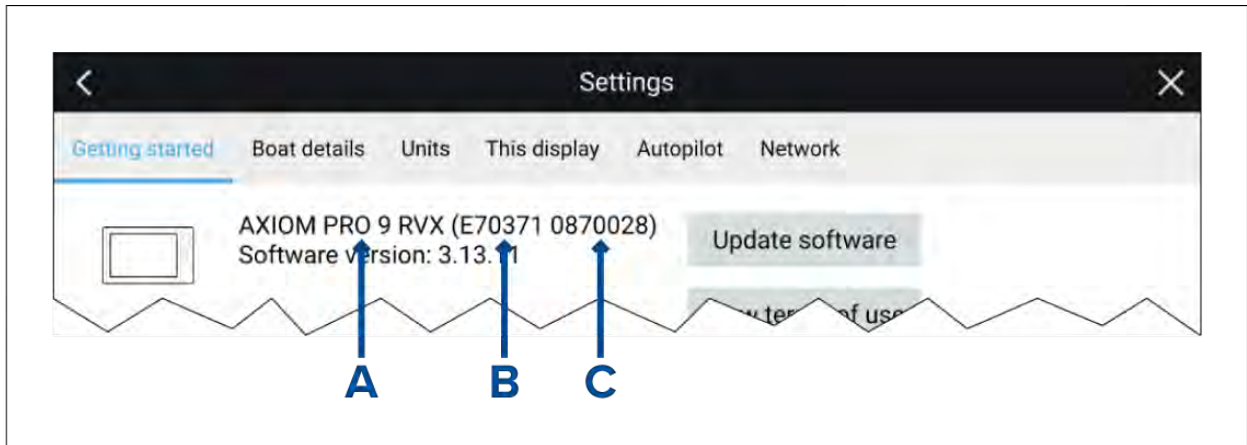

- **A** — Product name
- **B** — Product number
- **C** — Serial number

2. Contact your Raymarine dealer or Raymarine technical support and supply them with the above information to obtain an S-63 MFD activation file.

You will be sent an S-63 MFD activation file specific for your MFD.

3. Copy the received file to a blank / empty MicroSD card.
4. Insert the MicroSD card into the memory card reader slot of your MFD.

After a few seconds the MFD will detect and install the file. A notification is displayed onscreen when the installation is completed successfully.

The MFD will now be able to select S-63 Encrypted Charts and display them in the Chart app. Related settings will also be available.

Scheme administrator certificate

S-63 Encrypted Charts require a valid scheme administrator (SA) certificate. A current SA certificate is provided with the LightHouse™ 3 operating system software. Access to the SA certificate is provided when the S-63 MFD activation file is installed on your MFD.

The installed SA certificate is valid for a predetermined period of time after which it will expire. It is also possible for the IHO to issue a new certificate for security reasons.

When the SA Certificate expires an 'SSE-22' notification is displayed on your MFD and the SA certificate will require updating before you can update or buy new S-63 Encrypted Charts.

If the scheme administrator issues a new certificate then an 'SSE-06' notification is displayed on your MFD and the SA certificate will require updating before you can update or buy new S-63 Encrypted Charts.

Updated SA certificate can be obtained from the IHO website: <https://iho.int/en/>. Currently available on the following page: <https://iho.int/en/enc-data-protection>

You can replace the SA Certificate installed on your MFD from the SA certificate tab: **Chart app > Menu > Settings > Cartography > S-63 Settings > SA security certificate > Update SA security certificate.**

Copying user permit file(s) to memory card

When purchasing S-63 Encrypted Charts the vendor will require the user permit file(s) for the MFDs you want to use the charts on.

1. Insert a MicroSD card into your MFD's card reader.
 2. Open the **Cartography** settings tab in the Chart app: **Chart app > Menu > Settings > Cartography**.
 3. Select **S-63 Settings**.
 4. Select the **User permit** tab.
 5. Select **Save user permits to a file**.
 6. Select the card slot that you inserted the memory card into.
 7. Select **OK** on the confirmation dialog.
 8. Safely eject the memory card from your display using the Shortcuts page **Eject SD card** option.
- The S-63 user permit file must be sent to the chart vendor during the purchase process.

Purchasing S-63 Encrypted Charts

The process below describes a typical purchasing procedure; however, each vendor's process may be slightly different.

1. Create an account on the vendor's website.
2. Login to the account.
3. Select the chart regions you wish to purchase.
4. Send your MFD's user permits file to the chart vendor (this may be part of the checkout process).
5. Download the Cells permits file.
6. Download the Base cell file (this is typically a compressed 'zip' file).
7. Download the Cumulative update file (this is typically a compressed 'zip' file).

Important:

S-63 Encrypted Charts are locked to the MFD specified in the user permit file that you supplied to the chart vendor. If you have purchased charts for multiple MFDs (i.e. you supplied user permits to more than one MFD), you will need to ensure that you split the received cell permit files for each MFD.

Installing base cells and cell permits

When purchasing S-63 Encrypted Charts for the first time and as part of regular updates base cells and cell permits require installation before they can be used. The base cell files contain the cartographic data and the cell permits are used to authorize the use of the base cell files.

Typically the base cell files and their related cell permits are updated twice a year.

Note:

- Base cell files and the cell permits file must be installed before any available cumulative update files.
- It is recommended that base cell files, cumulative update files and the resulting installed chart files are all stored on separate memory cards, e.g.:
 - Card 1 = Base cell files and the cell permits file.
 - Card 2 = Cumulative update files and if applicable the cell permits file.
 - Card 3 = Installed charts (location that base cell files, cell permits file and cumulative update files are installed).

Note:

If you receive 'SSE' messages during the base cell installation, proceed with the cumulative update installation and this should resolve the errors. If errors persist after the cumulative update installation contact Raymarine product support for resolution..

1. Unzip the downloaded base cell file, using the 'Extract all' option of your PC's zip file application.

This ensures that the base cell files are created within a folder named the same as the original zip file.

2. Copy the folder and all contents to the root directory of your memory card.
3. Copy the received cell permits file to the root directory of the same memory card.
4. Insert the memory card into your MFD's card reader.
5. Open the Chart app's **Cartography** selection tab: **Chart app > Menu > Settings > Cartography**.
6. Select **Update S-63 charts**.
7. Select the card reader that contains the base cell files and cell permits file.

The card will be scanned for valid files and permits, this process can take some time. Once complete a list of available chart cells is displayed.

8. Select **Select all**, or select individual cells.
9. Select **Update selected charts** to install all base cells.
10. Select the card reader slot where you want the files to be installed.

Important:

The same 'Installed charts' card and memory card slot **MUST** be used to install and update base cell files and cumulative update files.

11. Wait for the installation to complete.

A progress bar is displayed as the base cells are installed.

12. Select **OK** on the successfully imported notification.

Note:

The installation process will create and store chart data in 2 folders on your memory card: 'senc' and 'seapilot', Overwriting, deleting or altering these folders or data within them will render your charts inoperable.

Installing cumulative updates

When purchasing S-63 Encrypted Charts for the first time and as part of regular updates any available cumulative updates require installation. The cumulative update files contain updated cartographic data.

Typically cumulative update files are made available fortnightly on the vendor's web server.

Note:

- Cumulative update files should be installed after the installation of base cell files.
- If a new cell permits file is received, this must be installed with the cumulative update.
- It is recommended that base cell files, cumulative update files and the resulting installed chart files are all stored on separate memory cards, e.g.:
 - Card 1 = Base cell and the cell permits file.
 - Card 2 = Cumulative update files and if applicable the new cell permits file.
 - Card 3 = Installed charts (location that base cell files, cell permits file and cumulative update files are installed).

Important:

If your chart vendor does not supply cumulative update files then updates must be installed separately and in release date order.

1. Unzip the downloaded cumulative update file, using the 'Extract all' option of your PC's zip file application.

This ensures that the cumulative update files are created within a folder named the same as the original zip file.

2. Copy the folder and all contents to the root directory of your memory card.
3. If required, copy the new cell permits file to the root directory of the same memory card.

4. Insert the memory card into your MFD's card reader.
5. Open the Chart app's **Cartography** selection tab: **Chart app > Menu > Settings > Cartography**.
6. Select **Update S-63 charts**.
7. Select the card reader that contains the cumulative update files and if applicable, the new cell permits file.

The card will be scanned for updates, this process can take some time. Once complete the list of installed base cells is displayed and any cells that have updates available will be automatically selected.

8. Select **Update selected charts** to install all base cells.
9. Select the card reader slot where you want the files to be installed.

Important:

The same 'Installed charts' card and memory card slot **MUST** be used to install and update base cell files and cumulative update files.

10. Wait for the installation to complete.

A progress bar is displayed as the base cells are installed.

11. Select **OK** on the successfully imported notification.

Note:

The installation process will create and store chart data in 2 folders on your 'Installed charts' memory card: 'senc' and 'seapilot', Overwriting, deleting or altering these folders or data within them will render your charts inoperable.

Note:

If errors persist after the installation of cumulative update files contact Raymarine product support for resolution..

**Warning: Expired S-63 Encrypted Charts**

S-63 Encrypted Chart cells expire after a set period of time. Once expired the charts must not be used for navigation. You will be notified onscreen of the expiration. The charts must be updated before they can be used for navigation.

S-63 Encrypted Chart settings

With the S-63 MFD activation file installed the S-63 Encrypted Charts related settings are available on the Cartography settings tab.

- **Update S-63 charts** — This option is used to decrypt your purchased S-63 Encrypted Chart data so that they can be displayed on the MFD.
- **View installed S-63 charts** — View a table of all currently installed chart cells
- **S-63 settings** — Access the following S-63 related settings:
 - **SD card** — Choose external storage location used for the Installed charts.
 - **User permit** — View and save user permits to file,
 - **SA security certificate** — View and update installed SA certificate.

8.3 Navigation

Navigating to a waypoint or point of interest

You can perform a “Goto” to a Waypoint or specific location.

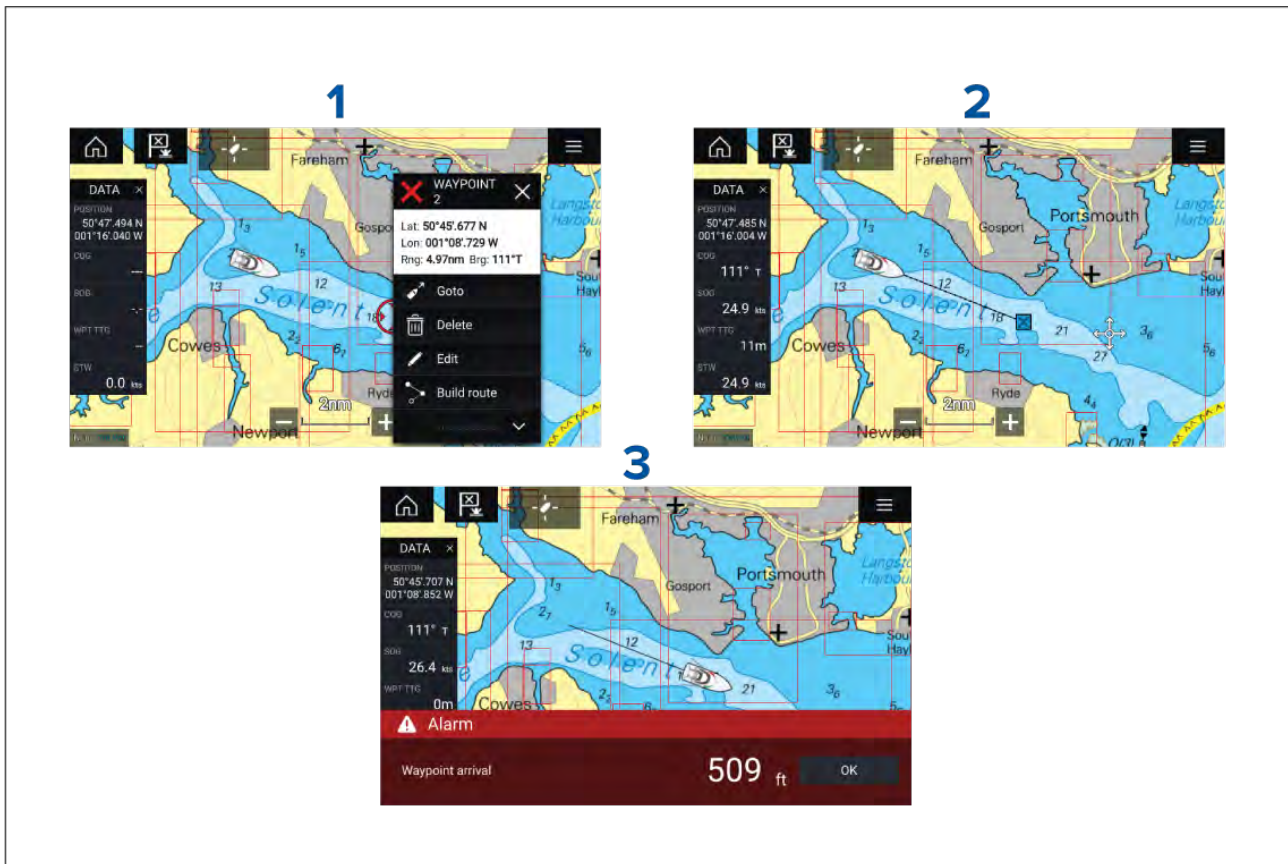

1. Select and hold on the waypoint or point of interest and select **Goto** from the context menu.

*You can stop the **Goto** at any time by selecting and holding anywhere in the Chart app and choosing **Stop**, or selecting another **Goto**.*

2. The Chart app will begin navigation, if required physically engage your autopilot.
3. An alarm will sound when you reach the waypoint.

You can also perform a Goto from the **Go** menu: **Menu > Go > Waypoint** or **Menu > Go > Lat/long**.

For more information on waypoints and waypoint management refer to: [Chapter 7 Waypoints, Routes and Tracks](#)

Restarting cross track error (XTE)

A cross track error (XTE) occurs when your actual route diverges from your original planned route. Restarting XTE plots a new course directly from your current position to your destination, rather than continuing to follow the original planned route.

1. Select **Restart XTE** from the **Navigation** menu: **Menu > Navigation > Restart XTE**.

Following a Route

You can start active navigation / follow a route from its starting waypoint.

With the Route displayed in the Chart app:

1. Select and hold on any Route leg (line drawn between the Route's waypoints) that you want to follow.
2. Select **Follow Route**.

Following from here

You can start active navigation / follow a route from any of its waypoints.

With the Route displayed in the Chart app:

1. Select and hold on any Route waypoint that you want to follow the Router from.
2. Select **more options**.
3. Select **Follow from here** to follow the route from the selected waypoint to its last waypoint.

8.4 Depths and contours

Depth soundings

Water depth measurements displayed on charts are called Depth soundings.

Usually Depth soundings are shown using major and minor units, with minor units being smaller and subscript e.g.: Depending on units of measure '1₅' would mean 1.5 metres, 1 Fathom and 5 feet or 1.5 feet.

Raster charts

On Raster charts the units of measure the used for Depth soundings is fixed. The display of Depth soundings is also fixed and will only change depending on Chart app range scale.

Vector charts

On Vector charts Depth soundings will use the units of measure specified for depth in the MFD's settings: **Homescreen > Settings > Units > Depth units:**

Depth sounding values appear differently onscreen:

Example LightHouse™ Charts Depth soundings

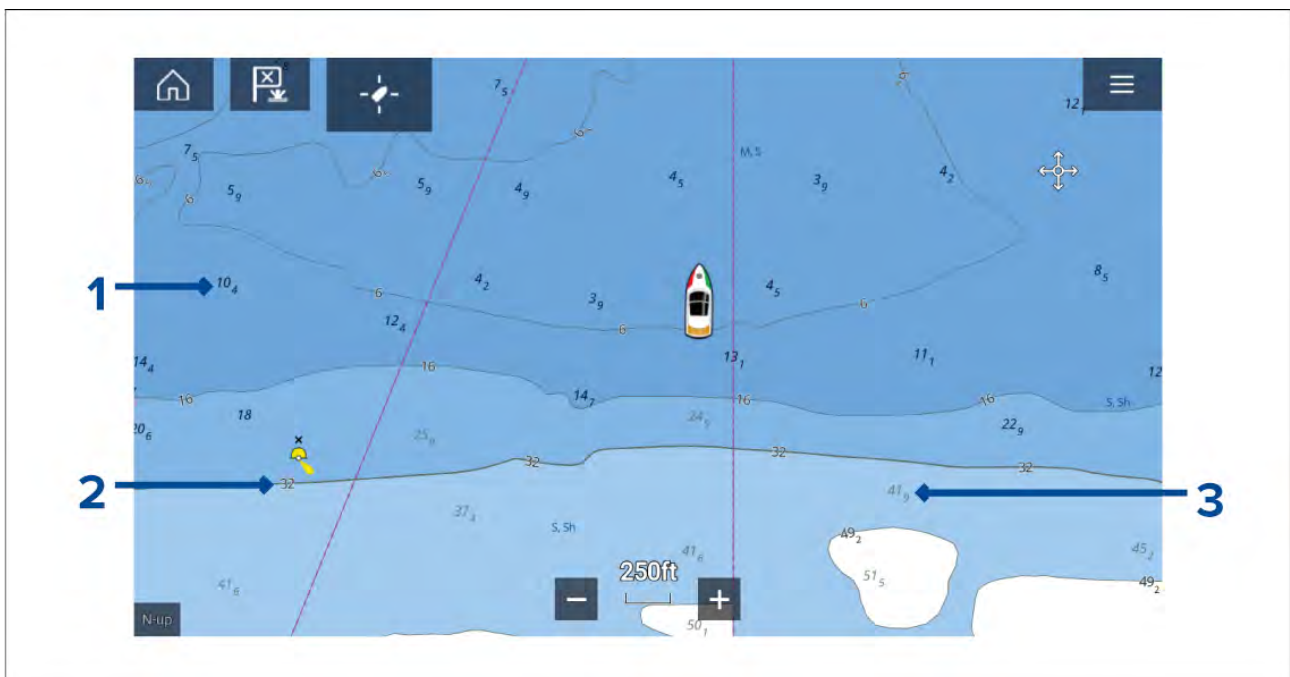

1. Bold depth soundings — Depth soundings displayed in Bold reflect depths shallower than the specified Safety contour depth.
2. White outlined depth soundings — Depth soundings displayed with a white outline 'Haloed' are reflect a depth contour.
3. Gray depth soundings — Depth soundings displayed in Gray reflect depths deeper than the specified Safety contour depth.

On Vector charts Depth soundings can be customized from the **Depths** settings menu: **Menu > Settings > Depths > Show soundings.**

The following Depth soundings options are available:

- **None** — No Depth soundings are displayed unless they are linked to a depth contour.
- **Manual** — Depth soundings are only shown from zero to the depth specified in the **Zero to:** option.
- **All** — All Depth soundings are displayed.

When **Show soundings** is set to **All** all depth soundings will be displayed.

Depth contours

Depth contours, also known as bathymetric contours or depth curves are lines drawn on cartography that connect points of equal depth creating a visualization of underwater bottom structure. Contours use color fills to indicate depth in relation to other contours.

Raster charts

On Raster charts Depth contours are fixed and are always displayed.

Vector charts

On Vector charts Depth contours can be customized from the **Depths** settings menu: **Menu > Settings > Depths > Show contours..**

Depth contours include Depth soundings. The Depth contour soundings are differentiated from other Depth soundings by using a white outline.

The following Depth contour options are available:

- **None** — No Depth contour lines or depth contour soundings are displayed.
- **Manual** — Depth contours are only shown from zero to the depth specified in the **Zero to:** option.
- **All** — All Depth contours are displayed.

Note:

The Depth contours option does not effect the contour fill color.

Example LightHouse™ Charts Depth contours

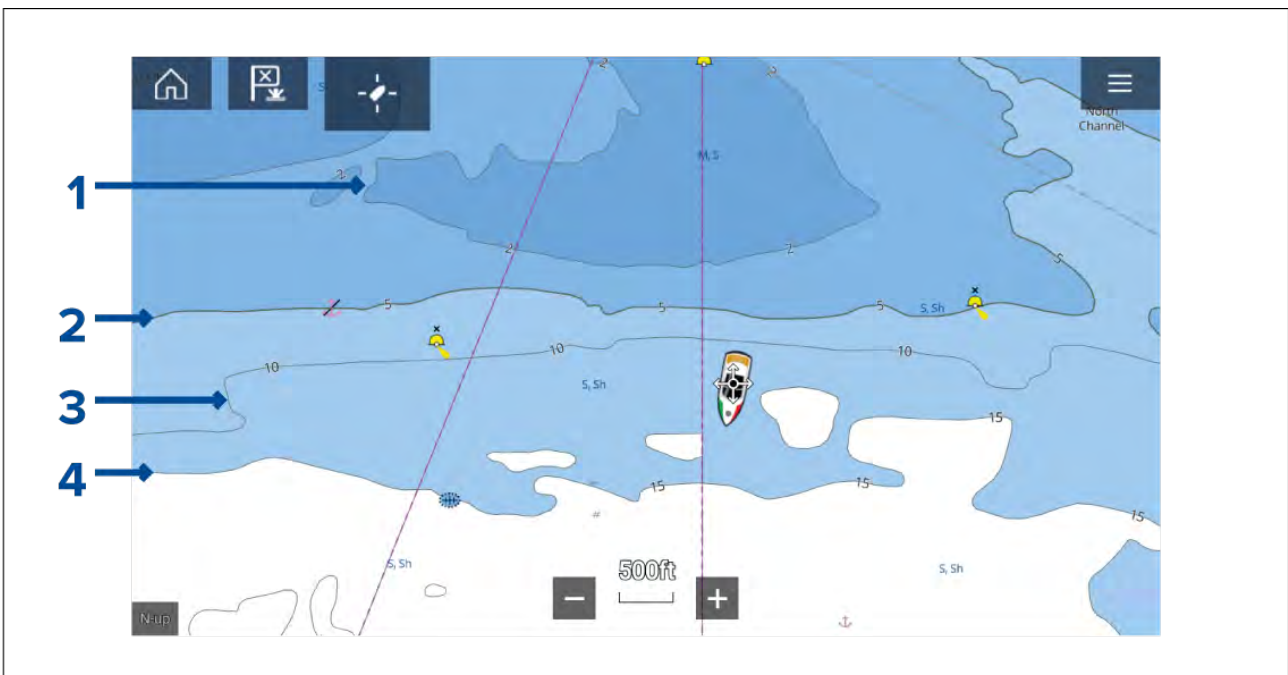

1. **Shallow contour** — Depths from zero to the depth specified in the **Shallow contour** setting will be within the Shallow contour, by default the Shallow contour uses the darkest shade of blue.
2. **Safety contour** — Depths from the **Shallow contour** to the depth specified in the **Safety contour** setting will be within the Safety contour. The Safety contour uses a thicker line than other contour lines and is colored using a medium shade of blue.

Important: The Safety contour should be set to the same value as your vessel's **Minimum safe depth** and should be used to identify areas where you should not take your vessel.

The Safety contour should be set to the same value as your vessel's **Minimum safe depth** and should be used to identify areas where you should not take your vessel.

3. **Depth contour** — All Depth contours consist of a line and depth soundings that appear along the line.
4. **Deep contour** — Depths from the **Safety contour** to the depth specified in the **Deep contour** setting will be within the Deep contour, by default the Deep contour uses the lightest shade of blue. By default depths greater than the Deep contour will be colored white.

Shallow contour, Safety contour and Deep contour values can be customized from the **Depths** settings menu: **Menu > Settings > Depths** .

Depth gradient

By default the color gradient used for depth contours is **Dark to Light** as described in the example above. If required the **Depth gradient** change be changed to **Light to Dark** which will invert the colors so that white is used for the Shallow contour and the darkest shade of blue is used for depths deeper than the Deep contour value.

The Depth gradient can be changed from the **Depths** settings menu: **Menu > Settings > Depths** .

Note:

Charts from different cartography vendors will handle depth contours differently.

Navionics depth contours

When using Navionics® charts depth contours are automatically colored using a blue color gradient with the shallowest contour using the darkest shade and the deepest using white.

Example Navionics® Charts Depth contours



1. **Shallow area** — When the **Shallow area** feature is enabled all depths from zero to the depth specified in the **Zero to:** setting will use red cross hatching to identify shallow areas.
2. **Depth contour** — All depth contours are identified using a line and a blue color fill gradient.
3. **Deep contour** — All depths deeper than the depth specified in the **Deep contour:** setting is colored white by default.

Deep water color

The color used for the Deep contour can be set to either white or blue. When set to blue the Deep water contour will use the lightest shade of blue.

The depth contour settings can be accessed from the **Depths** settings menu: **Menu > Settings > Depths** .

C-MAP depth contours

When using C-MAP® charts depth contours are automatically colored using a blue color gradient with the shallowest contour using the darkest shade and the deepest using white.

Example C-MAP® Charts Depth contours

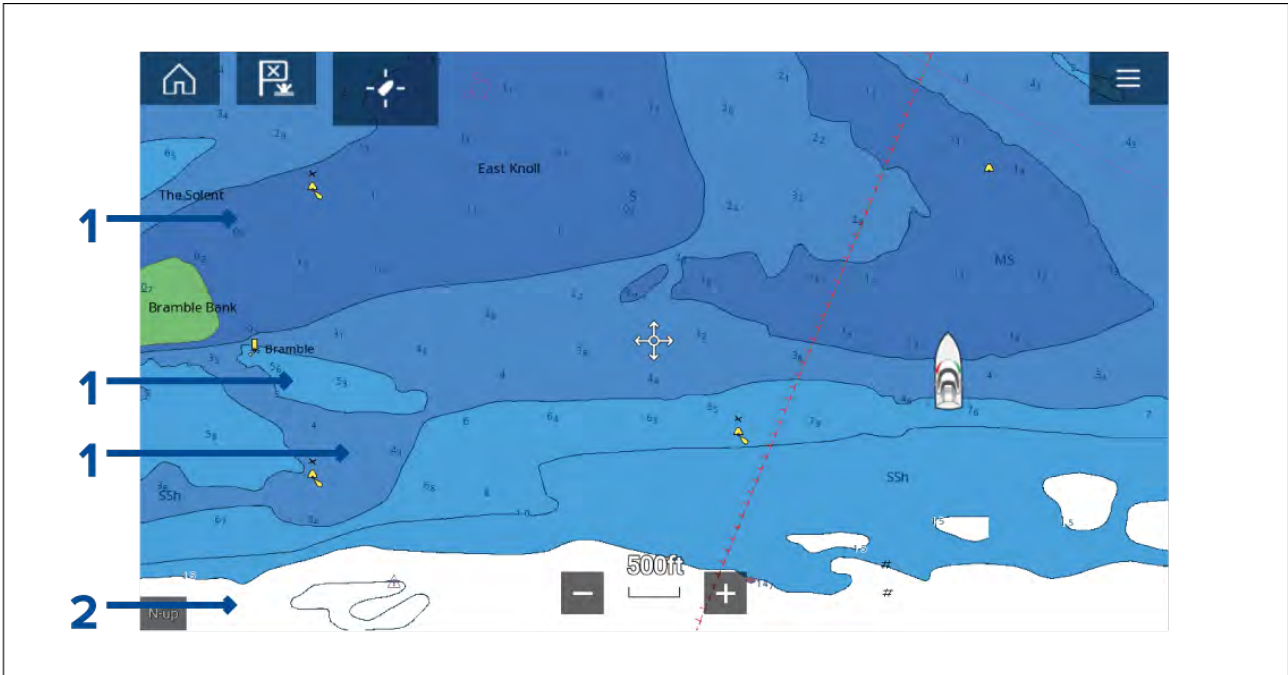

1. **Depth contours** — All depth contours are identified using a line and a blue color fill.
2. **Deep contour** — All depths deeper than the depth specified in the **Deep contour:** setting is colored white by default.

Deep water color

The color used for the Deep contour can be set to either white or blue. When set to blue the color fill shading is switched so that the Deep water contour will use the darkest shade of blue and the blue fill will get lighter the shallower the contour.

The depth contour settings can be accessed from the **Depths** settings menu: **Menu > Settings > Depths** .

8.5 Target tracking

The MFD is able to track and display various types of targets to improve situational awareness and collision avoidance. The types of targets which can be tracked are dependent on connected hardware and MFD configuration.

The following types of targets can be tracked:

- **AIS targets** — When a compatible AIS receiver or AIS transceiver is connected AIS targets can be tracked. For details on AIS targets refer to: [p.143 — AIS targets](#)
- **Radar targets** — When a compatible Radar scanner is connected Radar targets can be tracked. For details on Radar targets refer to: [p.150 — Radar settings](#)
- **DSC targets** — When the MFD is configured as 'First responder' vessel's sending out a DSC distress call can be tracked. For details on DSC targets refer to: [p.213 — DSC targets](#)
- **Intel targets** — When the MFD is configured as 'First responder' targets can be created manually by entering the targets position, course and speed. Intel targets can be tracked. For details on Intel targets refer to: [p.211 — Intel targets](#)
- **TOIs** — When the MFD is configured as 'First responder' targets can be designated as 'Targets Of Interest (TOI)'. For details on TOIs refer to: [p.214 — Target Of Interest \(TOI\)](#)

Targets that are being tracked are displayed onscreen in the Chart app and Radar app using representative icons and are listed in relevant target lists.







The target lists can be accessed by selecting **Targets** from the Radar app and Chart app menu: **Menu > Targets** , and then selecting the relevant tab.

AIS targets

AIS icons are used to identify AIS targets onscreen.







By default the following icons are used:

AIS icons

	Vessel		SART (Search and Rescue Transponder)
	Land-based station		ATON
	SAR (Search and Rescue)		Virtual ATON

You can enable enhanced AIS target icons from the **AIS Settings** menu: **Menu > Targets > AIS Settings > Enhanced AIS targets** or the **Advanced** settings menu: **Menu > Settings > Advanced > Enhanced AIS targets**. When Enhanced AIS targets is enabled the Enhanced AIS icons are used.

Enhanced AIS icons





	Sailing Vessel		Commercial
	High speed vessel / Wing In Ground vessel		Cargo vessel
	Passenger vessel		Other

Enhanced AIS icons are scaled or outlined according to the reported size of the vessel, as shown below:

	Relative length (Gray outline)		
---	--------------------------------	--	--

The status of an AIS target can is shown using different colors, outlines and flashing as shown below:

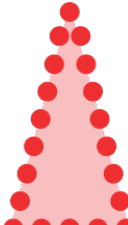
AIS target status

	<p>Lost (No border, crossed through)</p>		<p>Uncertain (Dashed outline)</p>
	<p>Buddy (Yellow fill)</p>		<p>Dangerous and Uncertain (Dashed outline and Flashes Red)</p>
	<p>Dangerous (Flashes Red)</p>		<p>ATON off position (Red border)</p>

Note:

When the MFD is configured as 'First responder' and is connected to STEDs compatible AIS hardware, Blue Force AIS icons are used to identify other STEDs equipped vessels. For details refer to: [p.220 – Blue Force Tracking](#)

AIS target information

Vessels with AIS transceivers can broadcast programmed vessel information, this information can be displayed in the Chart app.

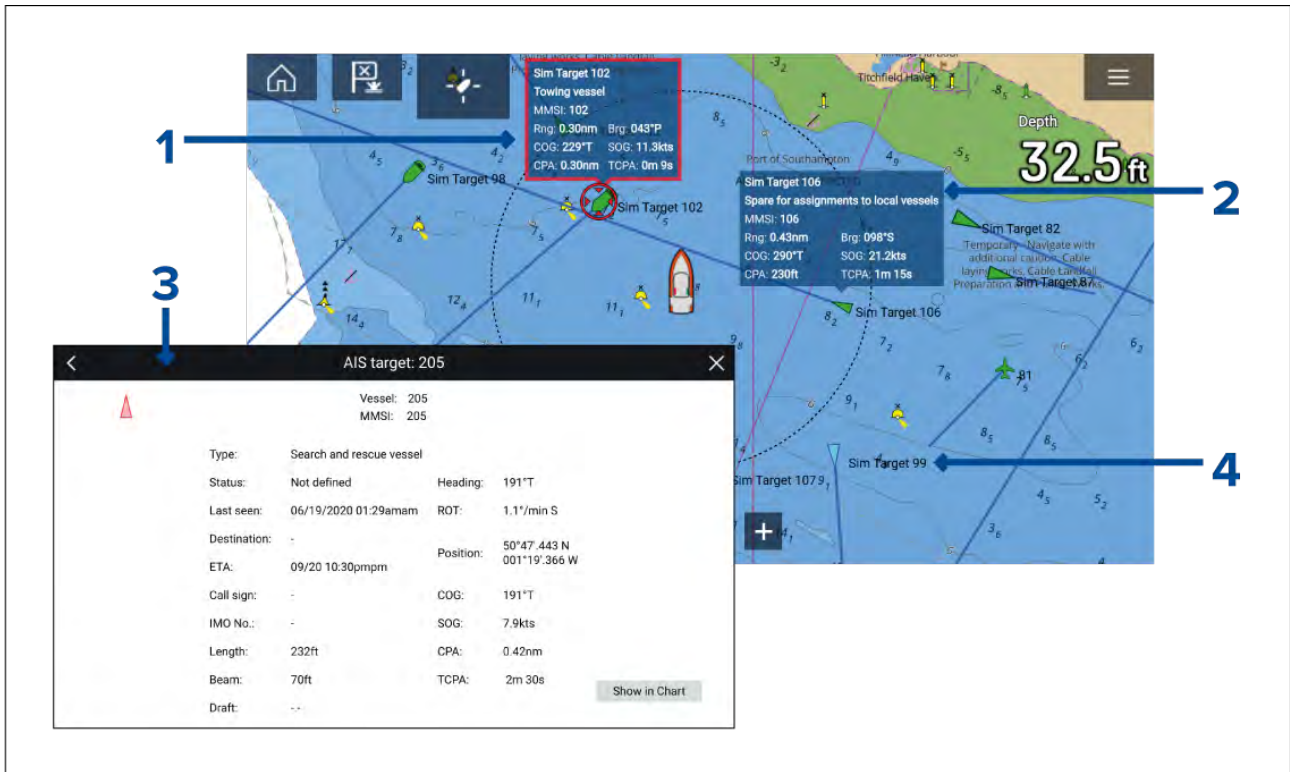

1. Selecting an AIS target icon in the Chart app will display an Infobox containing AIS identification and position information. The Infobox will close automatically after approximately 5 seconds.
2. The Infobox can be switched on and off for individual targets from the AIS target context menu. When switched on the Infobox is always displayed for the selected target.
3. Full AIS data can be viewed by selecting **View AIS data** from the AIS target context menu or by selecting a target from the target list and selecting **View full target data** from the pop-over menu.
4. The AIS target name can be displayed next to the target icon. AIS names can be switched on and off from the **AIS Settings** menu: **Menu > Targets > AIS Settings > AIS names**.

Accessing target options

Target specific options are available for targets that are currently being tracked. The target options can be accessed from the target's context menu and from the Pop-over options in the relevant target list. The options available are dependent on the type of target.

To access a target's context menu:

- Press and hold on the target onscreen, or
- Highlight the target onscreen using the **Direction controls** and press the **OK** button.

To access the target list Pop-over menu:

- Select the target in the relevant target list, or
- Highlight the target in the list using the **Direction controls** and press the **OK** button.

AIS target options

The following options are available for AIS targets.

- **View full target data** — View fullscreen page displaying all available AIS data.
- **Add as buddy** — Add the target as a buddy. The Buddy feature enables you to add AIS-equipped friends and regular contacts as 'buddies'. Buddy vessels will be displayed onscreen and in the target list using the Yellow AIS buddy icon. When assigning an AIS target as a buddy you can customize the name that is used for the target vessel. The following additional Target list Pop-over options are available for buddy vessels:
 - **Remove as buddy** — The target will revert to using normal AIS target icon.
 - **Edit buddy name** — Change the Name of the buddy target.
- **Intercept** — Initiates a Target interception. For details see: [p.163 — Target intercept](#)

AIS target list

The target list identifies: Target name, Range and Bearing from your vessel. Where relevant, CPA (Closest point of approach) and TCPA (Time to Closest Point of Approach) values will also be displayed.

The AIS targets list can be accessed from the Targets menu in the Radar app and Chart app: **Menu > Targets > AIS**

The target list is sorted by target proximity to your vessel with the closest target appearing at the top of the list. The list will automatically update as targets become closer or farther away.

Selecting a target from the list highlights the selected target in the LiveView app pane on the right of the page and opens the Pop-over menu.

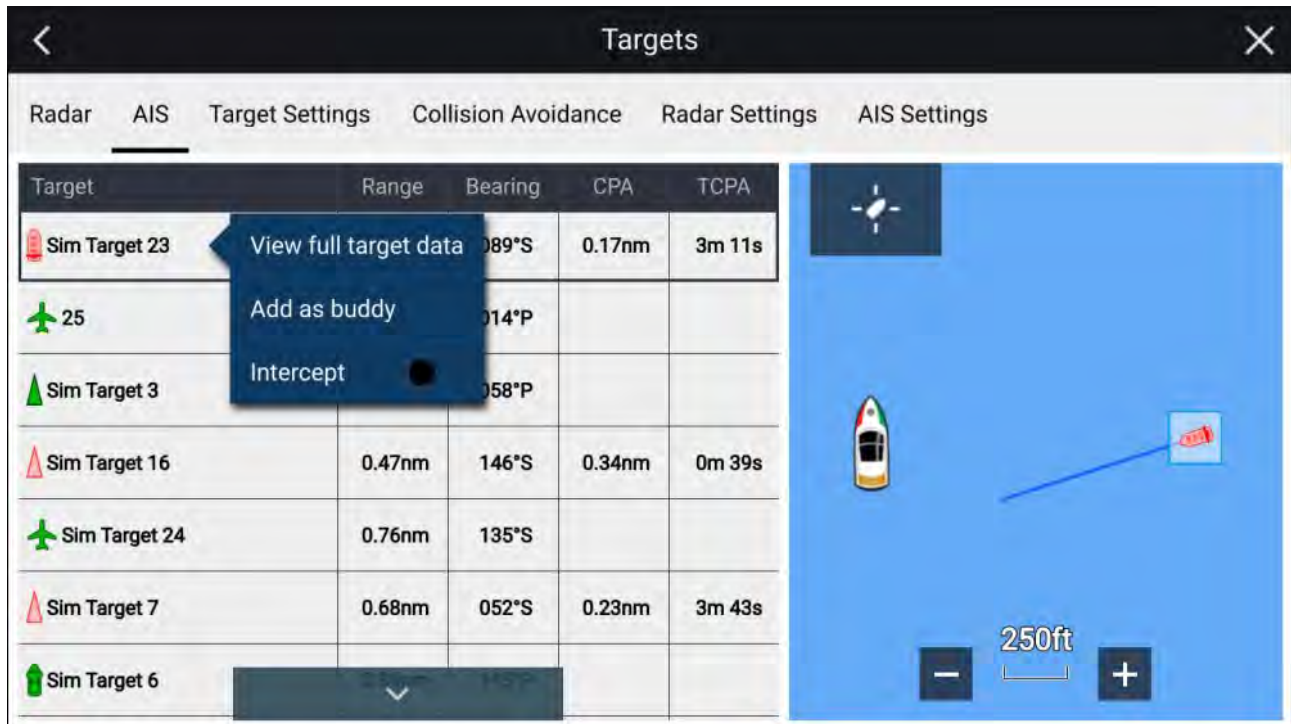

AIS settings menu

You can configure AIS target settings from the **AIS Settings** menu: **Menu > Targets > AIS Settings**.





The following options are available:

- **Show AIS targets in chart / Show AIS targets in Radar** — Enables and disables display of AIS targets in the Chart app / Radar app.
- **Enhanced AIS targets** — Enables and disables the display of enhanced AIS target icons.
- **AIS names** — When enabled, AIS target names are permanently displayed next to AIS target icons.
- **Show these AIS types** — Enables selection of the types of AIS target that will be displayed.
Available AIS types:
 - All
 - Dangerous
 - Buddies
- **Hide static targets** — When enabled, AIS targets travelling under 2 knots will not be displayed, unless it is or becomes dangerous.
- **Silent mode (don't transmit my position)** — When enabled, your vessel's AIS transceiver will not transmit your position or details to other AIS equipped vessels.

Radar targets

Radar target symbols are used to identify Radar targets onscreen.

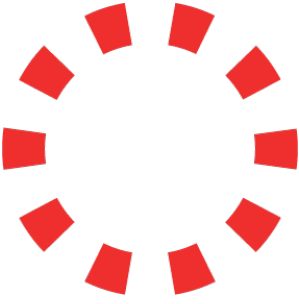
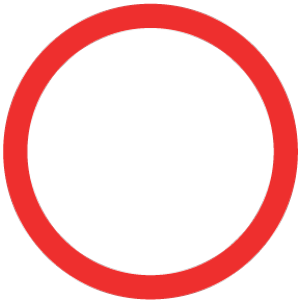
Radar targets are displayed in the Radar app and when Radar overlay is enabled (**Chart app > Menu > Targets > Radar settings > RADAR OVERLAY > Show radar overlay**) they are also displayed in the Chart app.

	Acquiring target (manual) — Thin dashed Green circle		Acquired target (manual) — Green circle with Target ID
	Acquiring target (auto) — Thick dashed Red circle, flashes until acknowledged		Unacknowledged acquired target (auto) — Red circle, flashes until acknowledged
	Dangerous target — Red circle with Target ID, flashes until acknowledged		Lost target (Target not detected for 4 Radar scans) — Gray circle with Red cross through

Once acquired the target's COG (Course Over Ground) and SOG (Speed Over Ground) can be displayed below the target ID.

The Target info is colored Blue if COG and SOG values are True or Orange if values are Relative. Target info will turn Red if the target becomes dangerous.

Acquiring a target manually

To acquire a Radar target manually using MARPA (Mini Automatic Radar Plotting Aid) follow the steps below.

With the Radar overlay enabled:

1. Select the object / target.
The context menu is displayed.
2. Select **more options**.
3. Select **Acquire target**.
Once acquired the target will be tracked.

Accessing target options

Target specific options are available for targets that are currently being tracked. The target options can be accessed from the target's context menu and from the Pop-over options in the relevant target list. The options available are dependent on the type of target.

To access a target's context menu:

- Press and hold on the target onscreen, or
- Highlight the target onscreen using the **Direction controls** and press the **OK** button.

To access the target list Pop-over menu:

- Select the target in the relevant target list, or
- Highlight the target in the list using the **Direction controls** and press the **OK** button.

Radar target options

The following options are available for Radar targets.

- **Cancel target** — Cancels the Radar target. Once cancelled the target symbol will no longer be displayed onscreen or be listed in the target list.

Note: Cancelled targets will not be tracked and will not trigger the dangerous target alarm.

- **Show CPA** — Determines when CPA graphics are displayed onscreen. The following options are available:
 - Auto — CPA graphic is displayed if the target becomes dangerous (based on the Dangerous target alarm settings).
 - On — CPA graphic is displayed if there is an interception point between your vessel's current course and the target's.
 - Off — CPA graphic is not displayed for the target.

Note: CPA graphics are only displayed in the Radar app. The **Show CPA** option is not available in the Chart app.

- **Target info** — Enables and disables display of the target's Course (COG) and speed (SOG) onscreen.
- **Intercept** — Set target interception. For details see: [p.163 — Target intercept](#)

Radar target list

The target list identifies: Target number, Range and Bearing from your vessel. Where relevant, CPA (Closest point of approach) and TCPA (Time to Closest Point of Approach) values will also be displayed.

The Radar target list can be accessed from the Targets menu in the Radar app and Chart app:

Menu > Targets > Radar.

The Radar target list can be sorted by either Number or Range by selecting the **Sorted By** option located at the bottom of the LiveView pane:

- Number — List sorted by Target number so that the first detected target appears at the top of the list.
- Range — List sorted by proximity to your vessel with the closest target appearing at the top of the list. The list will automatically update as targets become closer or farther away.

Selecting a target from the list highlights the selected target in the LiveView app pane on the right of the page and opens the Pop-over menu.

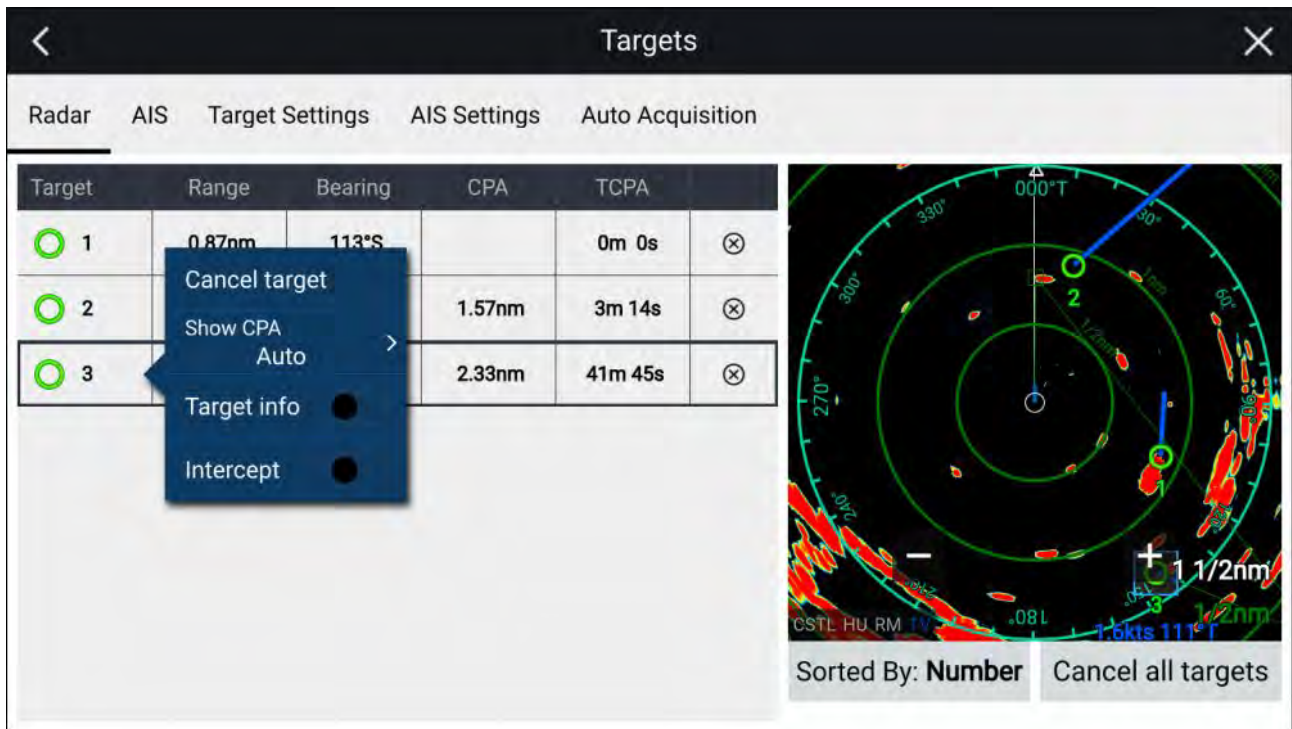

Radar targets can be cancelled individually by selecting the 'X' next to the target's details in the list, or you can cancel all targets by selecting **Cancel all targets**.

Radar settings

When the Radar layer is enabled in the Chart app you can configure the **Radar settings** from the **Targets** menu: **Menu > Targets > Radar settings**.

The following options are available:

- **Radar selection** — When more than 1 Radar scanner is connected you can choose which Radar to use for the Radar layer in the Chart app.
- **Transmit** — Start the Radar scanner transmitting or put it in Standby.
- **Dual range** — Enables and disables dual range on compatible Radar scanners.
- **Channel** — When Dual range is active, you can switch between channel 1 and 2.
- **Sync radar range with chart** — Enables and disables the synchronization of Chart app range with all Radar app instances on the same app page.

Note: The current range is synchronized when the setting is enabled. Subsequent range changes in either the selected Chart app instance or any Radar app instance on the same app page will be synchronized.

- **Show Radar overlay** — Enables and disables the Radar layer in the Chart app.
- **Visibility** — Determines the percentage visibility (opacity) of the Radar layer.
- **Palette** — The Radar overlay can be displayed in the following colors:
 - Full Color (256 colors)
 - Purple
 - Black
 - Red

Note: When 'Full color' is selected, approaching objects are displayed in Pink.

- **Show sector blanking limits** — Enables and disables blank sectors on compatible radar scanners. For more information on blank sectors refer to [12.12 Blank sectors](#)
- **DOPPLER** — Enables and disables Doppler on compatible radar scanners. For more information on Doppler refer to [12.11 Doppler Radar overview](#)

Note: If 'Full color' is selected for the Radar overlay palette, approaching targets will appear Pink instead of Red.

- **Use COG when no Heading data available** — Enables use of the Radar layer when Heading data is not available.
- **Range** — Determines the range used for the Radar layer.

Target vector settings

Target vectors show the predicted future path of the target.

Target vector settings can be accessed from the **Targets** setting menu: **Menu > Targets > Target settings**.

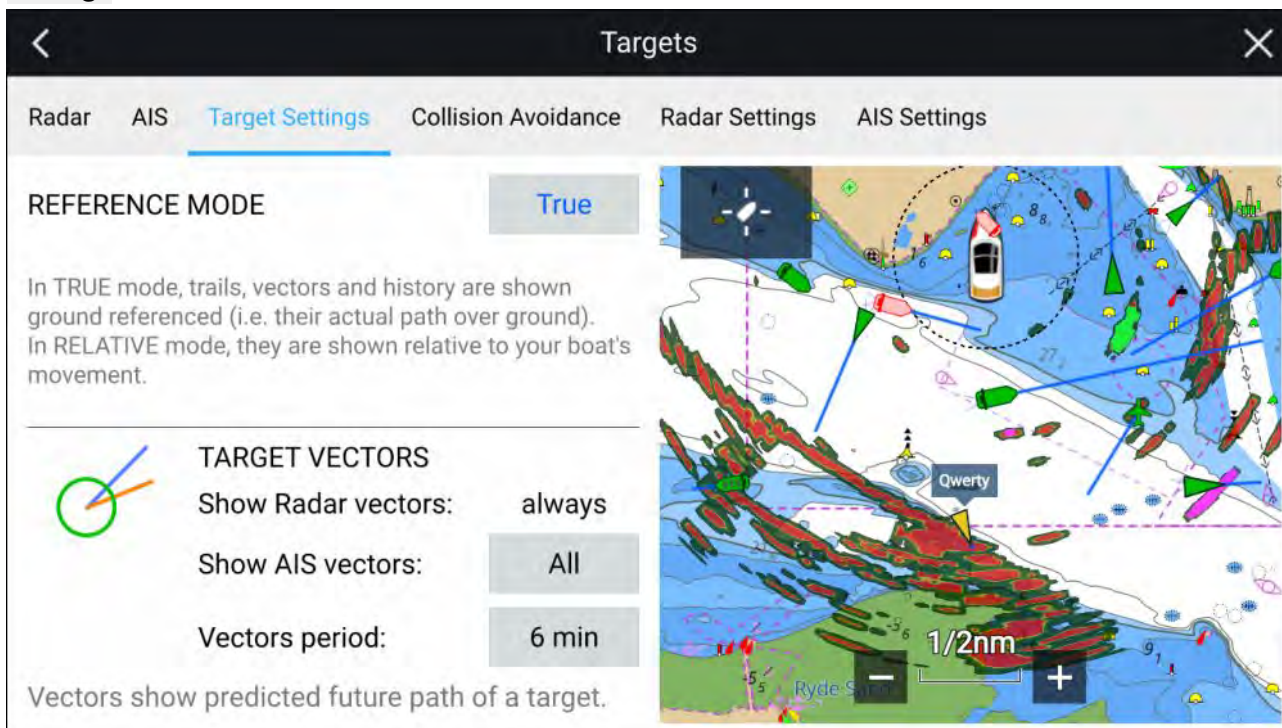

The reference mode for vectors can be set to **True** or **Relative**.

- In **True** reference mode, trails, vectors and history are shown ground referenced (i.e. their actual path over ground).
- In **Relative** reference mode, trails, vectors and history are shown relative to your vessel's movement.

Vectors are always displayed for Radar targets. Vectors for AIS targets can be set using the **Show AIS vectors** option. The available options are:

- **All** — vectors are displayed for all AIS targets.
- **Manual** — vectors only displayed when enabled individually for each target using the target context menu.

The length of the vector identifies where the target will be after the time specified in **Vector period** has passed.

8.6 Collision avoidance

In addition to target tracking specific collision avoidance features are available to improve awareness for the potential of collisions.

The specific collision avoidance features are:

- Dangerous targets alarm. Refer to: [p.152 — Dangerous targets alarm](#)
- Radar guard zones. Refer to: [p.280 — Guard zone alarms](#)
- Predicted areas of danger. Refer to: [p.152 — Predicted areas of danger](#)
- LightHouse chart obstruction alarm. Refer to: [p.161 — Obstruction alarm \(LightHouse charts\)](#)

Dangerous targets alarm

Use the Dangerous targets alarm to notify you if a Radar target or AIS target will reach a specified distance from your vessel within a specified time.

The Dangerous targets alarm settings can be accessed from the **Collision Avoidance** menu: **Menu > Targets > Collision Avoidance**.

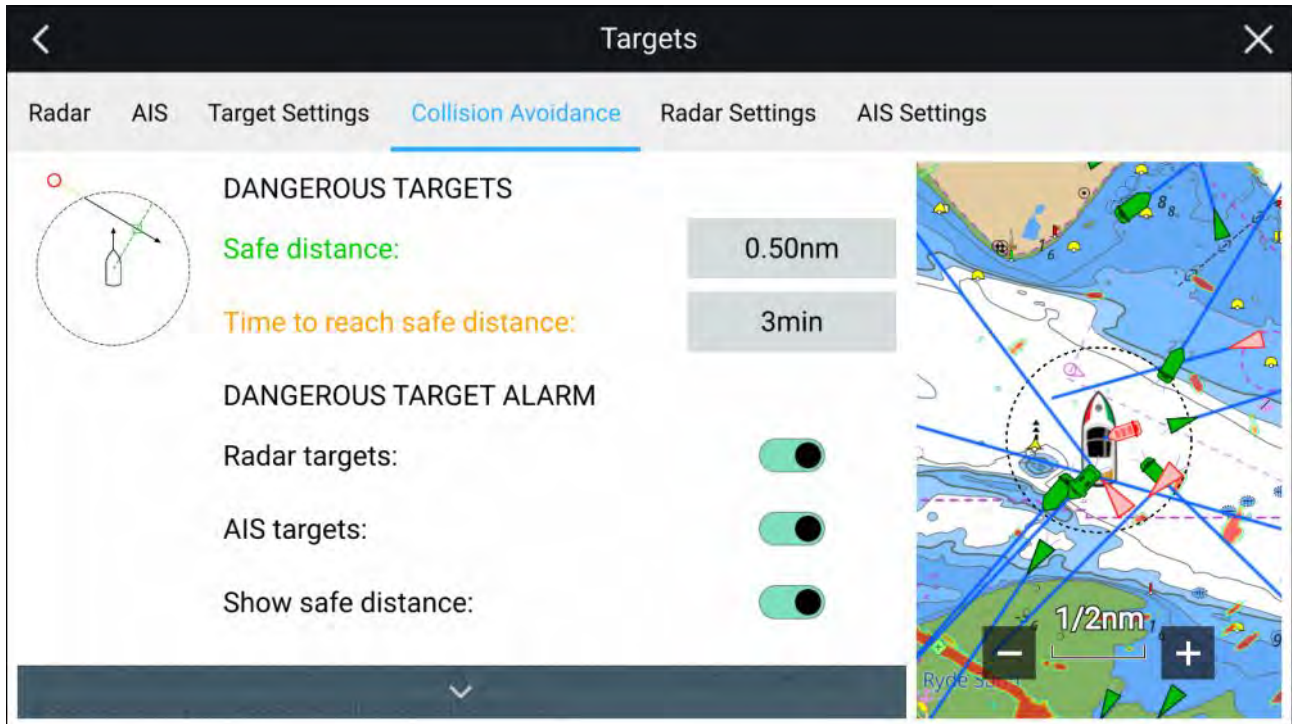

To set up the Dangerous targets alarm, adjust the **Safe distance** to the desired value and then select a **Time to reach safe distance**. The alarm will be triggered if a tracked target will reach the specified Safe distance from your vessel within the time period selected.

You can enable and disable the targets that will trigger the alarm using the **Radar targets** and **AIS targets** toggle switch. When disabled the targets will not trigger the Dangerous targets alarm.

You can display a Safe distance ring around your vessel in the Chart app by enabling the **Show safe distance** toggle switch.

Predicted areas of danger

The Predicted areas of danger feature tracks Radar targets and AIS targets in relation to your own vessel's Course Over Ground (COG) and Speed Over Ground (SOG).

If your paths are predicted to cross an Interception line is displayed from your vessel and the target. Additionally, Interception zones are displayed to indicate where there is an increased risk of collision. The Interception line and the Interception zones are based on your current course and speed and the target's current course and speed and can help you determine whether you should change course and / or speed to avoid a potential collision.

The graphics automatically refresh when the MFD receives new position data from the target.

Important:

The Collision Avoidance feature is a graphical aid only, provided to help increase user awareness of the potential for collision. It is vital to have a good understanding of the *International Regulations for Preventing Collisions at Sea* (IRPCS / COLREGS), to ensure all actions taken are in accordance with the IRPCS. Important concepts to understand in relation to Collision Avoidance include (but are not limited to): Risk assessment; Right of Way; Restricted visibility; interpreting lights and shapes; interpreting sound and light signals. In the event of conflict, the IRPCS regulations must take precedence. For more information on IRPCS / COLREGS, refer to: [IRPCS](#)



Moving target graphics

Moving target graphics are used for targets moving greater than 2 kts.

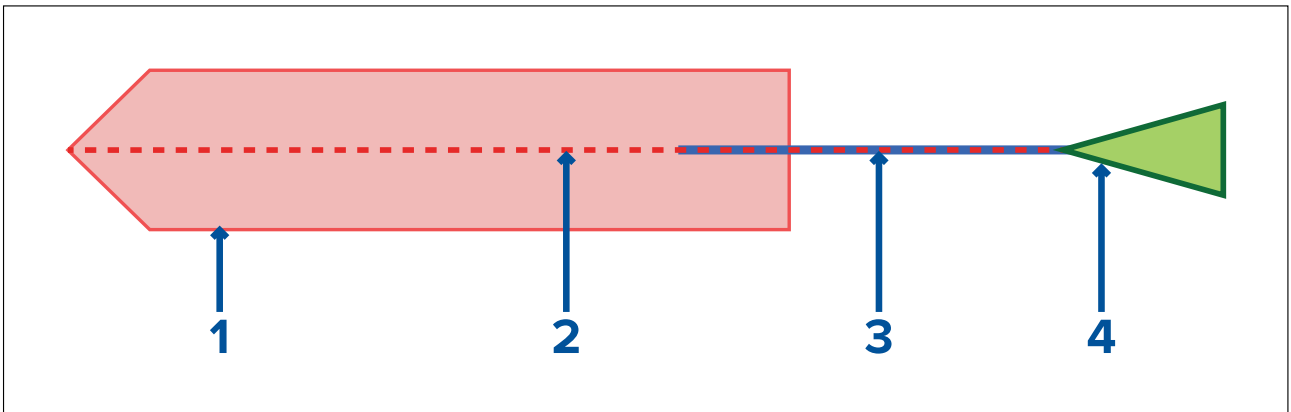

1. Interception zone (Predicted area based on target's last reported position)
2. Interception line
3. Target COG line
4. AIS Target (Last received position)

Stationary Target graphics

Stationary target graphics are used for targets moving less than 2 kts.

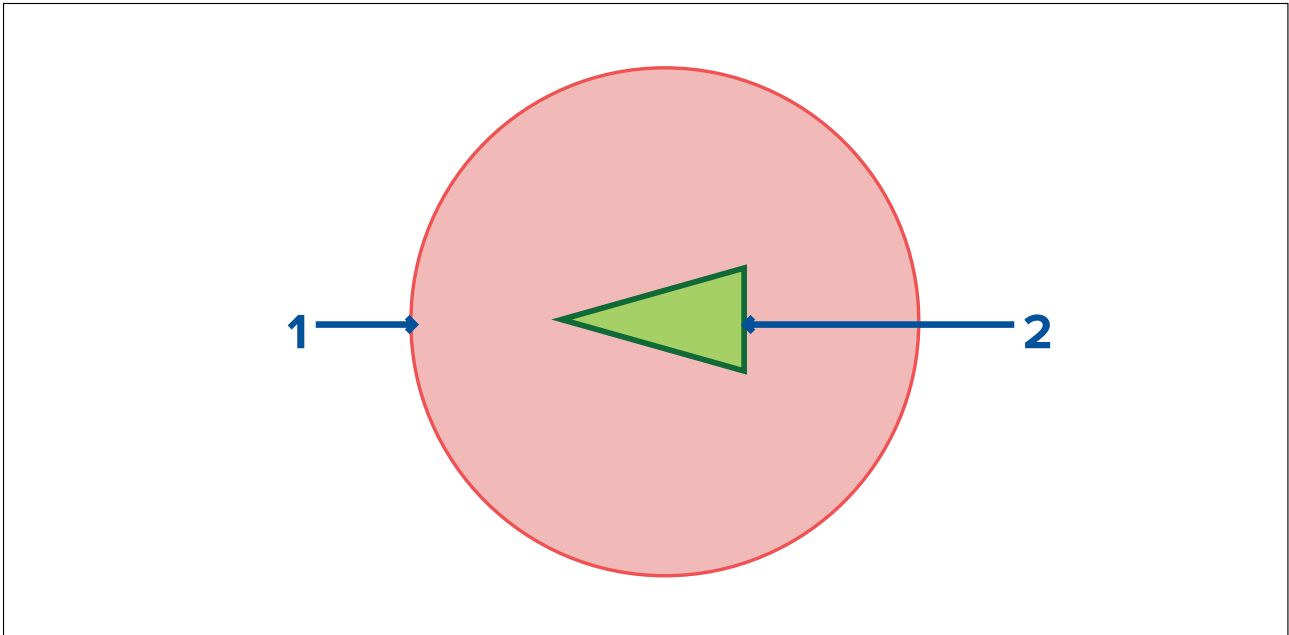

1. Interception zone (Predicted area based on target's last reported position)
2. Stationary AIS Target (Last received position)

Important:

You must still maintain a permanent watch for:

- Vessels that are not equipped with AIS or AIS-equipped vessels that are not currently transmitting their position, as these targets will not be displayed in the Chart application.
- AIS-equipped vessels reporting an inaccurate GPS position, your own vessel's GPS accuracy, or AIS targets with delayed location updates. These situations will cause your vessel's position and / or AIS target positions to be displayed inaccurately in the Chart application.
- Objects not detected by your Radar scanner.

Predicted areas of danger settings

The Predicted areas of danger feature can be enabled for AIS targets and Radar targets in the Chart app.

Chart app > Menu > Targets > Collision Avoidance

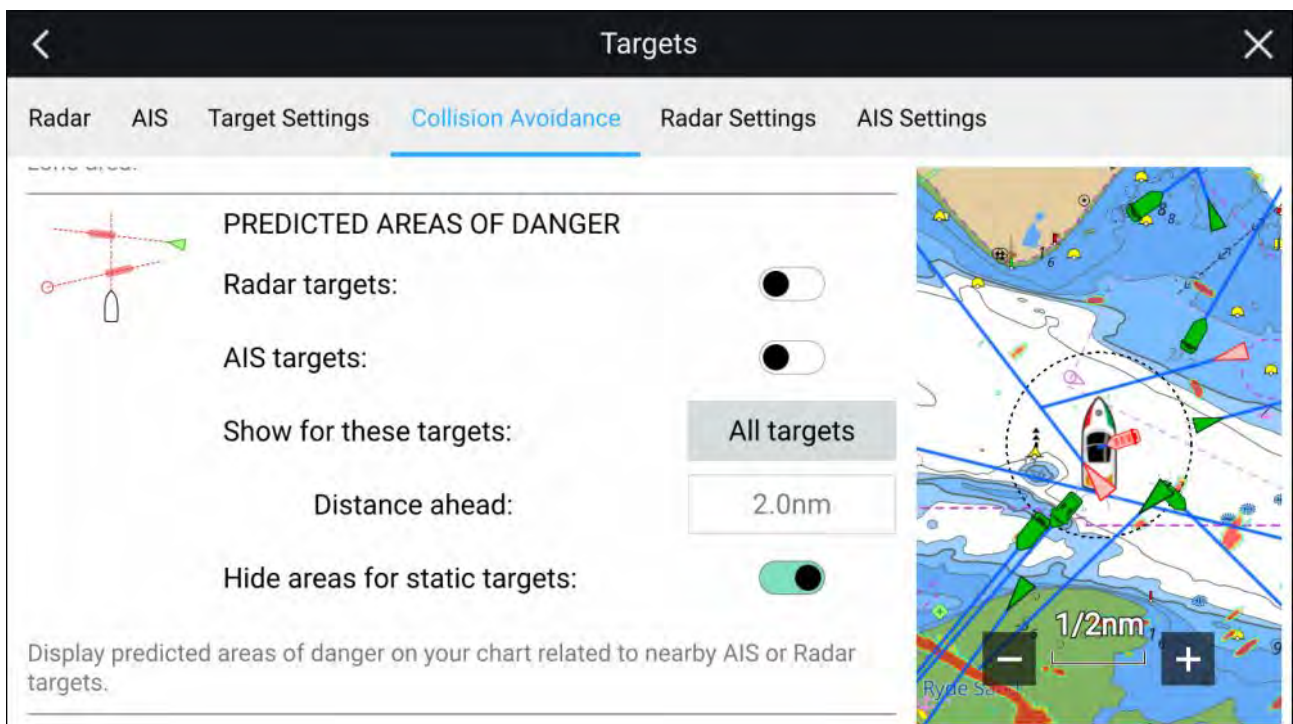

In the **Collision Avoidance** menu you can change the settings to determine which types of target (i.e. AIS and Radar) will have an Interception zone:

- **Radar targets** — Enables and disables Predicted area of danger graphics for detected Radar targets.
- **AIS targets** — Enables and disables Predicted area of danger graphics for AIS targets.
- **Show for these targets** — Determines when Predicted area of danger graphics are displayed. Graphics can be displayed for:
 - **All targets** — all targets onscreen.
 - **Targets crossing my course** — only targets which are predicted to cross your vessel's path
- **Distance ahead** — Changes the distance ahead of your vessel that the Interception line is drawn (only available with **Targets crossing my course** selected). The distance can be set to a value between 0.5 nm to 5.0 nm.
- **Hide areas for static targets** — Enables and disables graphics for Static targets, targets travelling less than 2.0 kts will NOT have Predicted area of danger zones.

Collision scenarios

There are 3 potential scenarios the Predicted areas of danger feature can warn you about:

- Own vessel moving faster than target
- Target moving faster than own vessel
- Both targets moving at similar speed

Example scenario 1 — Own vessel moving faster than target vessel

Note: These scenarios are examples provided for guidance only.

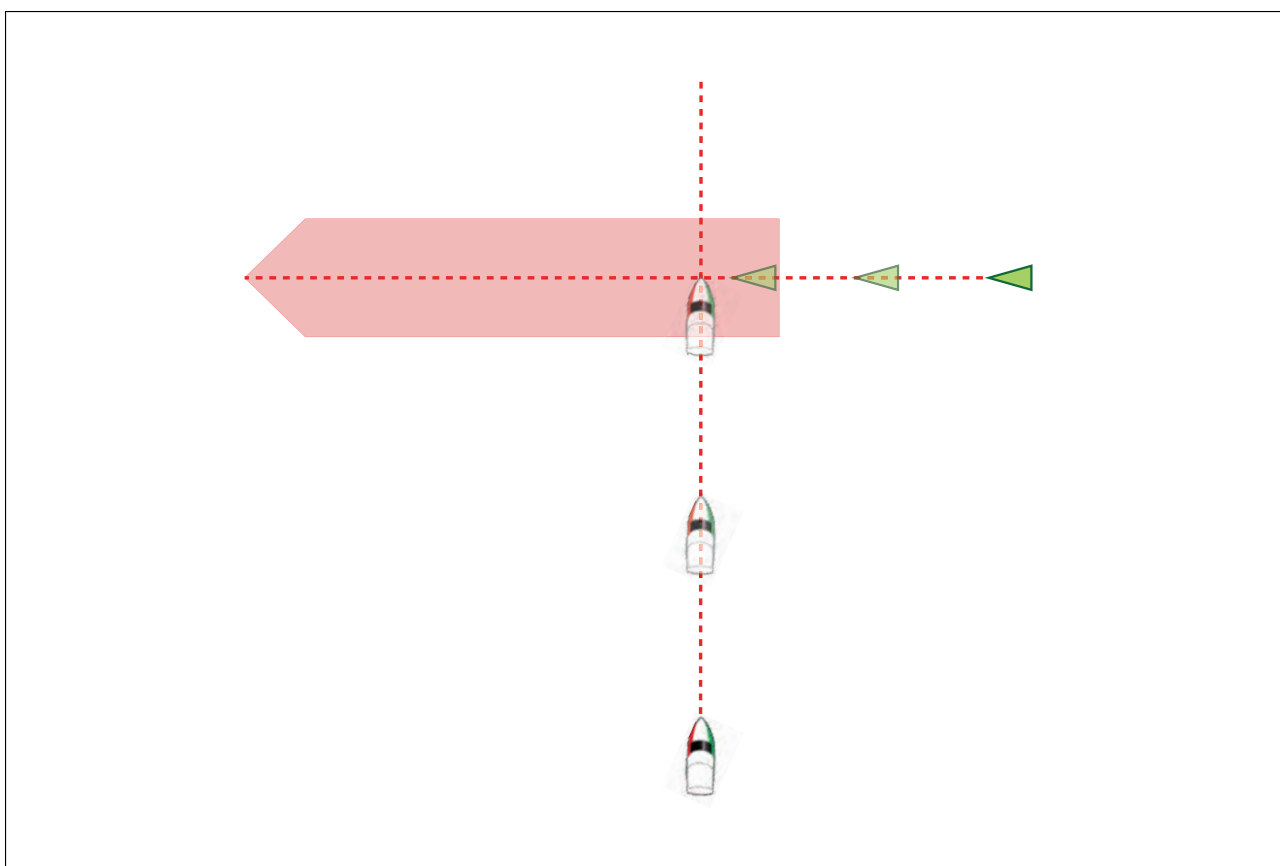

In the example above the vessel's COG will cross with the target's COG within the Interception zone, which could cause a collision. You should alter course and / or speed to avoid the potential collision.

Scenario 1 Course change examples

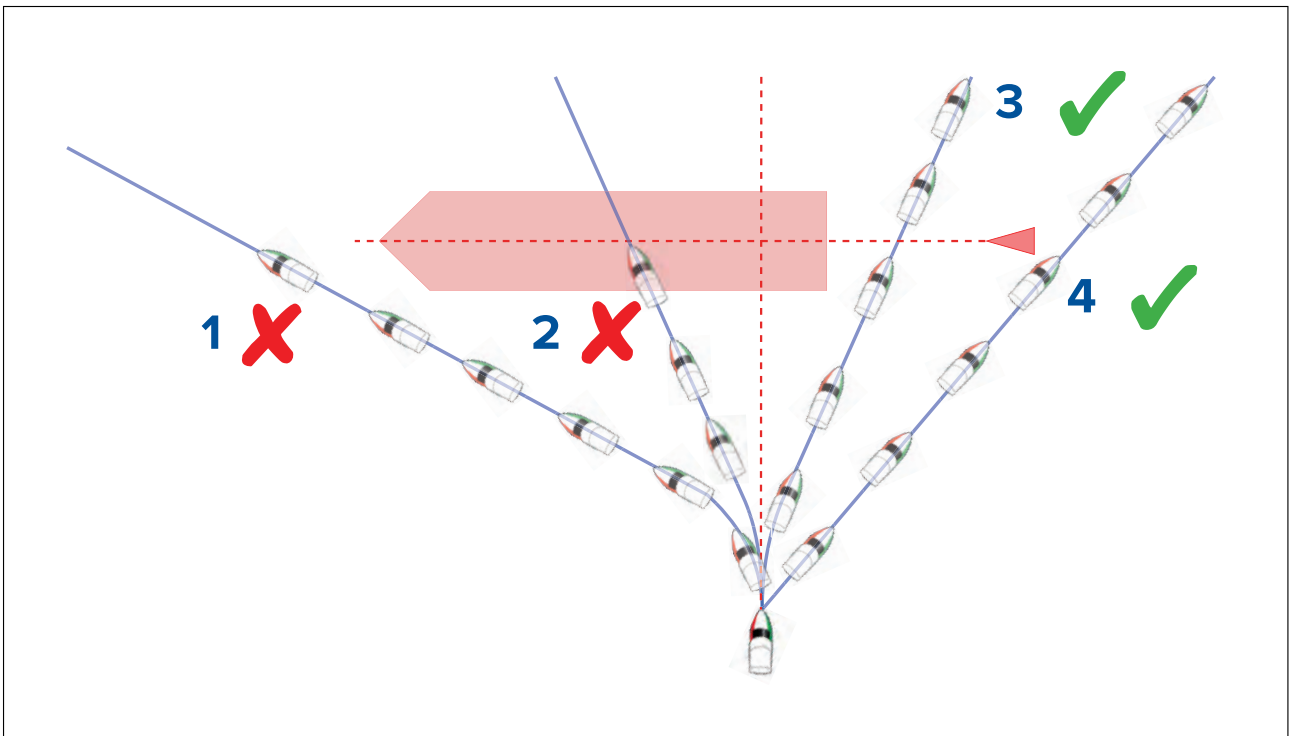

1. Course alteration to pass ahead of the Interception zone [**Not recommended**] — **Proceed with caution**, there is always an inherent risk when passing in front of other vessels.
2. Course alteration to pass ahead of the target vessel [**Not recommended**] — This manoeuvre is not recommended as your vessel will still cross through the target's Interception zone.
3. Course alteration to pass astern of the target vessel and its Interception zone — This manoeuvre alters your vessel's course so that it does not come into contact with the target's Interception zone and passes astern of the target.
4. Course alteration to pass clear astern of the target vessel and its Interception zone. This is the preferred manoeuvre as it correctly alters your vessel's course so that it is clear of the target's Interception zone and passes safely astern of the target. This manoeuvre also clearly indicates to the target vessel your actual change of course.

Figure 2. Scenario 1 Speed change examples

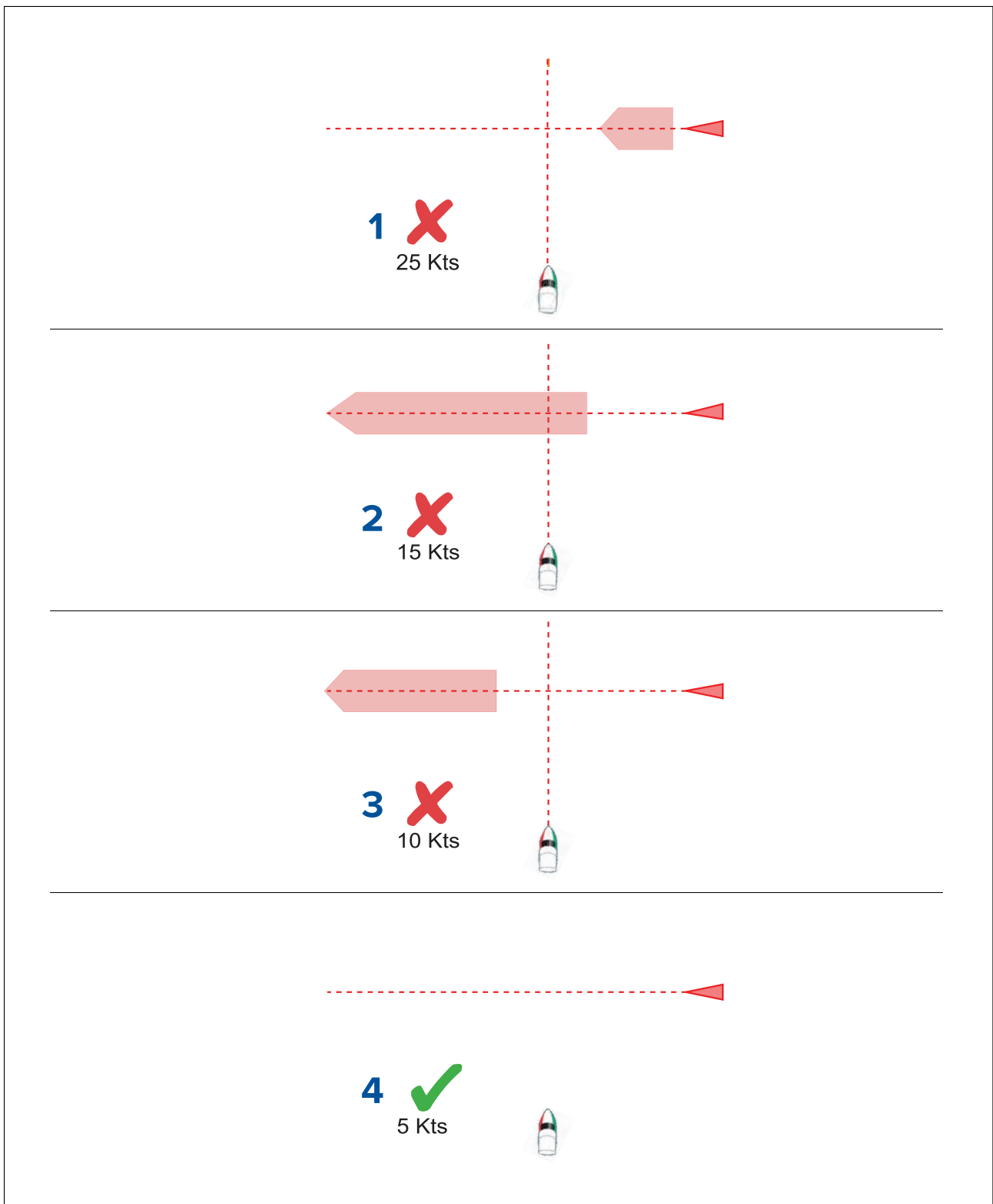

1. ⁽¹⁾**Speeding up [Not recommended]** — Increasing vessel speed to pass ahead of the target vessel. **Proceed with caution**, there is always an inherent risk when passing in front of other vessels.
2. **No speed change [Not recommended]** — Not changing speed or course is not an option as it can result in a collision.
3. **Slowing down [Not recommended]** — Slowing down a sufficient amount will allow the target vessel to pass ahead of your vessel.
4. ⁽²⁾**Slowing down** — Slowing down more than a sufficient amount will allow the target vessel to pass safely ahead of your vessel.

Note:

- ⁽¹⁾ In this example the paths will still cross within the **Intercept distance**, so the graphics are still displayed.
- ⁽²⁾ In this example the paths will no longer cross within the **Intercept distance**, so the graphics are not displayed.

Example scenario 2 — Target vessel moving faster than your vessel

Note: These scenarios are examples provided for guidance only.

In certain situations, when the target vessel is travelling faster than your vessel, there may be more than one opportunity for your paths to cross within the **Intercept distance**. If this is the case then a second Interception zone is displayed.

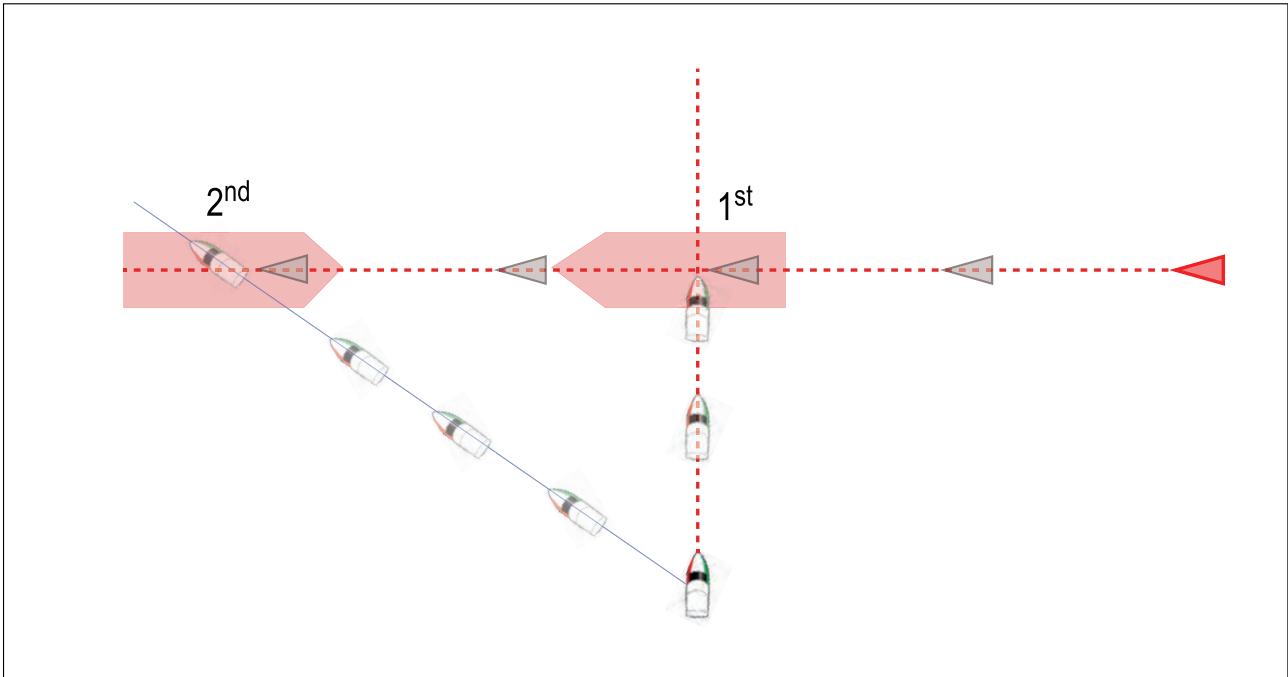

1. 1st — The first Interception zone (displayed closest to the target vessel) represents a bow-to-bow collision.
2. 2nd — The second Interception zone (displayed farthest from the target vessel) represents the target vessel running you down from behind.

When altering course and speed, both Interception zones must be avoided.

Scenario 2 Course change examples

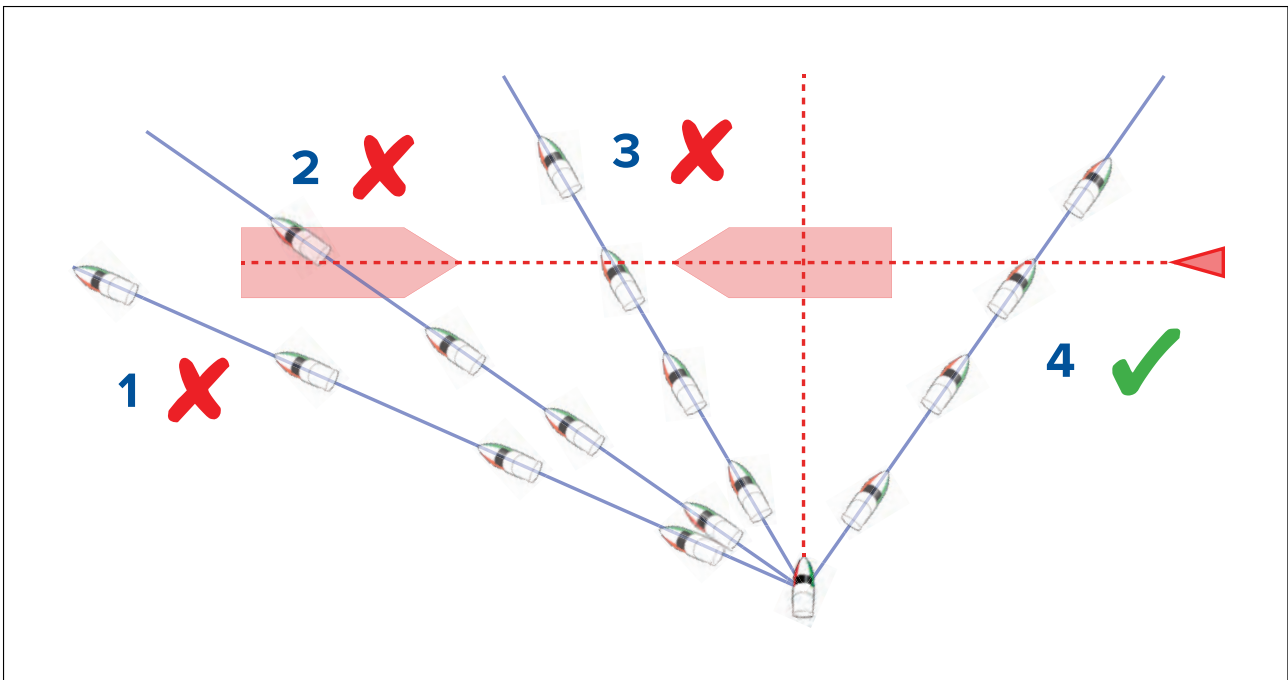

1. Course alteration to pass ahead of the Interception zone **[Not recommended]** — As the target vessel is moving faster than your vessel you will pass astern of the target.
2. Course alteration to pass ahead of the first Interception zone **[Not recommended]** — Although this course alteration is sufficient to avoid a potential bow-to-bow collision, it has created a second Interception zone where the target may now run you down from behind.
3. Course alteration to pass between the 2 Interception zones **[Not recommended]** — Although this may seem like the quickest option, **proceed with caution**, as the gap between the 2 Interception zones can close quickly, especially when your vessel slows down.
4. Course alteration to clear astern of the target vessel and its Interception zone. This would be the preferred manoeuvre as it correctly alters your vessel's course so that it is clear of the target's Interception zone, and passes safely astern of the target. This manoeuvre also clearly indicates to the target vessel your change of course.

Figure 2. Scenario 2 Speed change examples

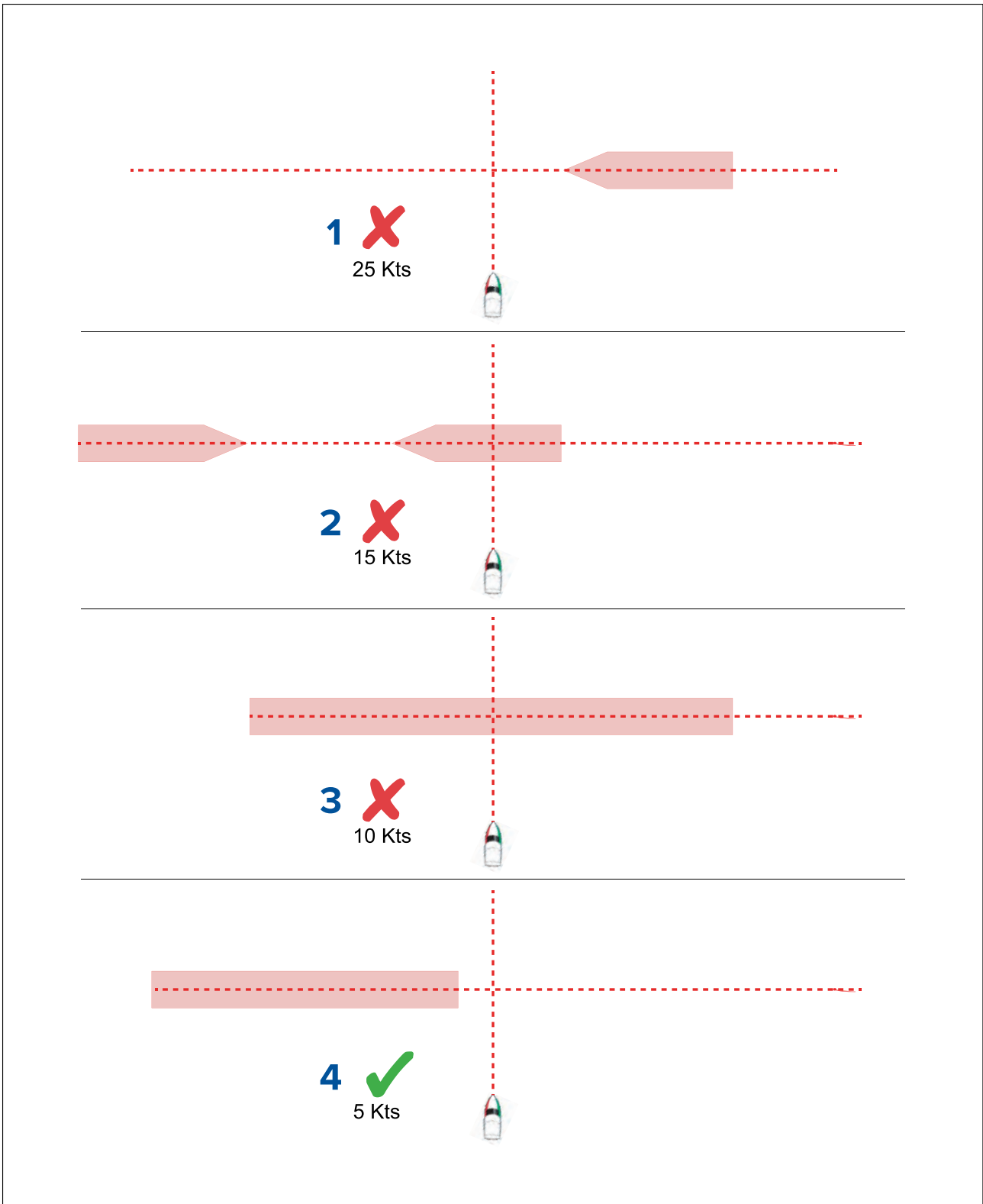

1. **Speeding up [Not recommended]** — Increasing vessel speed to pass ahead of the target vessel. **Proceed with caution**, there is always an inherent risk when passing in front of other vessels.
2. **No change [Not recommended]** — Not changing speed or course may result in a collision.
3. **Slowing down [Not recommended]** — Slowing down slightly may result in the 2 Interception zones closing up or merging into a single zone.
4. **Slowing down** — Slowing down a sufficient amount will allow the target vessel to pass safely ahead of your vessel, avoiding the Interception zone(s).

Example scenario 3 — Both vessels travelling at the same speed

Note: These scenarios are examples provided for guidance only.

Course change

When both vessels are travelling at the same speed, course alterations should be made in accordance with the guidance provided in examples 1 and 2.

Speed change

When both vessels are travelling at the same speed, altering your speed will change the collision scenario to one of the scenarios detailed in examples 1 and 2.

Obstruction alarm (LightHouse charts)

The Obstruction alarm provides a warning if a charted object, charted depth contour or charted height clearance is detected that conflicts with the MFD's configured **Safety depth** and / or **Safety height** settings.

Note:

- The Obstruction alarm requires LightHouse™ charts or Legacy LightHouse™ vector charts as the alarm's **Cartography source**.
- Object depths, depth contours and clearance heights are based on the cartography in use.
- If an obstruction is not present in the specified **Cartography source** it will not trigger the alarm.



When the Obstructions alarm is triggered an alarm notification is displayed and an audible beep is sounded on the MFD. From the onscreen notification you can acknowledge the alarm by selecting **OK**, or edit the alarm parameters by selecting **Edit**.

Obstruction alarm parameters

The Obstruction alarm parameters must be configured from the **Alarm manager** before it can be used: **Homescreen > Alarms > Settings > LightHouse chart obstructions**.

The following options must be configured for correct operation:

- **LightHouse chart obstructions** — Enables and disables the obstruction alarm.
- **Indication only** — Enables and disables the warning notification dialogue (Audible beep and Red detection zone outline only).
- **Cartography source:** — Choose the LightHouse chart relevant for you region.
- **Safety depth** — Specifies the minimum safe depth for your vessel. The Chart app's **Safe contour** depth value is synchronized with the Safety depth value.
- **Safety height** — Specifies the minimum height for your vessel.
- **Obstruction warning ahead** — Specifies how much time in advance of reaching the obstruction the alarm will be triggered. This means the faster your vessel speed is the farther ahead the detection zone will be drawn.
- **Minimum obstruction distance** — Specifies the minimum distance from your vessel to port, starboard, aft and when motionless, fore. The detection zone is displayed in the Chart app as an oblong shape around your vessel which turns Red when an obstruction is detected.

Obstruction alarm detection zone

If a Chart app instance is opened that uses the same LightHouse™ charts cartography as the Obstruction alarm's **Cartography source** then a detection zone is drawn around the vessel icon. The detection zone outline turns Red when the Obstruction alarm is triggered.



1. When there is no obstruction present the detection zone outline is colored black until an obstruction is detected.
2. When the charted depth is the same depth as or less than the specified safety depth the Obstruction alarm is triggered.
3. When the charted object is the same depth as or less than the specified safety depth the Obstruction alarm is triggered.

Once the Obstruction alarm has been configured the alarm parameters can be modified from the **Collision avoidance** menu tab in the Chart app: **Chart app > Menu > Targets > Collision Avoidance > LightHouse obstruction alarm**.

Note:

- You will not be able to use the Obstruction alarm if the **Cartography source** has not been set in the Alarms manager.
- Obstructions may not be displayed at all Chart app ranges so you may need to Range in to see the object that triggered the Obstruction alarm.

LightHouse charts dangerous objects

When using LightHouse™ charts or Legacy LightHouse™ vector charts objects deemed as dangerous are highlighted using a purple octagon symbol with an 'x' in the center.

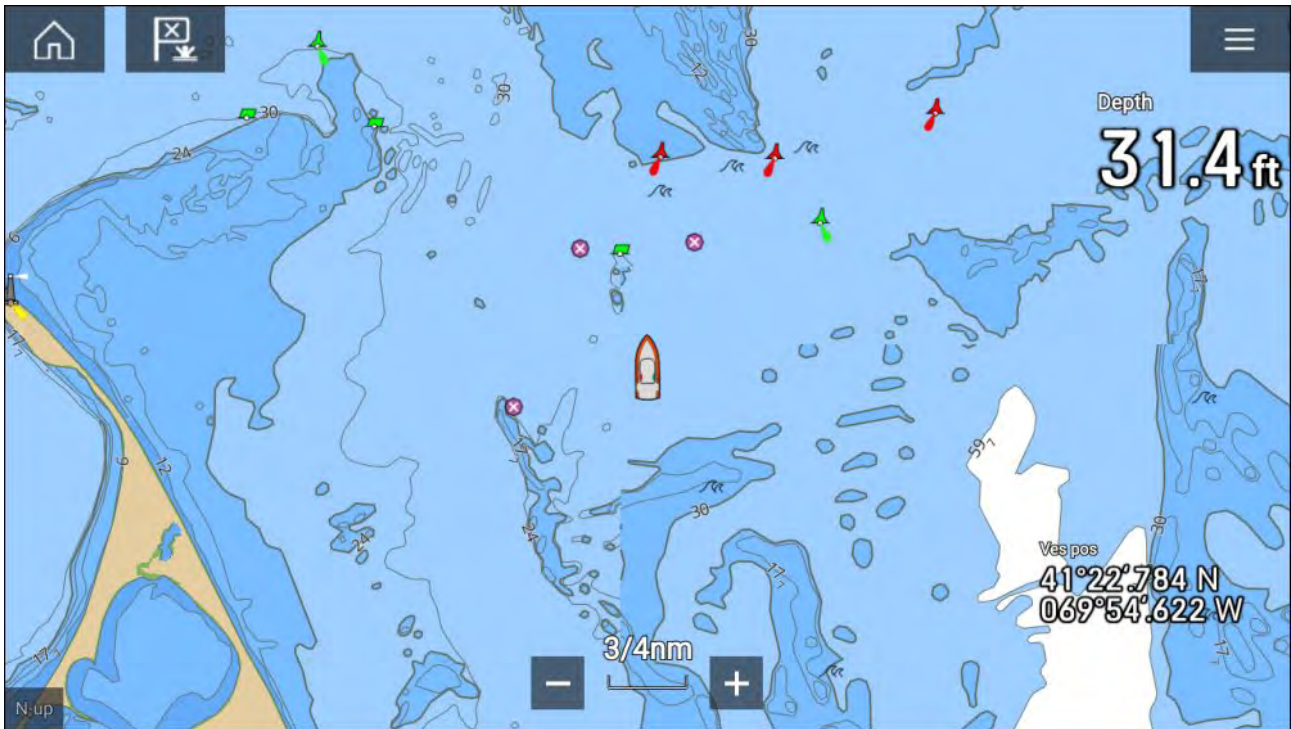

Objects such as wrecks, that are in the Deep contour that are shallower than the depth specified in the Safety contour will be highlighted using the Danger symbol.

Height restrictions such as bridges, are always highlighted using the Danger symbol.

Note:

When using Legacy LightHouse™ vector charts the display of Danger highlight symbols can be enabled and disabled from the Chart app's **Advanced** menu tab: **Menu > Settings > Advanced > Danger highlights.**

8.7 Target intercept

The **Intercept** feature can be used to help rendezvous with friends or for Pilot boats and the Coastguard to intercept vessels that are to be boarded.

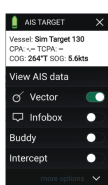

To use the **Intercept** feature, select and hold the target icon until the menu is displayed, then select **Intercept**. The Chart app will automatically plot a direct course to a point where your vessel and the target will cross (intercept).

An interception mark is placed at a predicted point where both your vessel and the target will cross.

Important:

When performing an individual interception, you are placing your vessel on a collision course with the target vessel. It WILL be necessary to change to a parallel course to prevent a collision.

Pre-requisites:

- It is vital to have a good understanding of the *International Regulations for Preventing Collisions at Sea* (IRPCS / COLREGS), to ensure all actions taken are in accordance with the IRPCS. For more information on IRPCS / COLREGS, refer to: [IRPCS](#)
- You must be familiar with the AIS feature.
- You must have a thorough understanding of the Target interception feature and its implications before attempting to use it in a real life scenario.

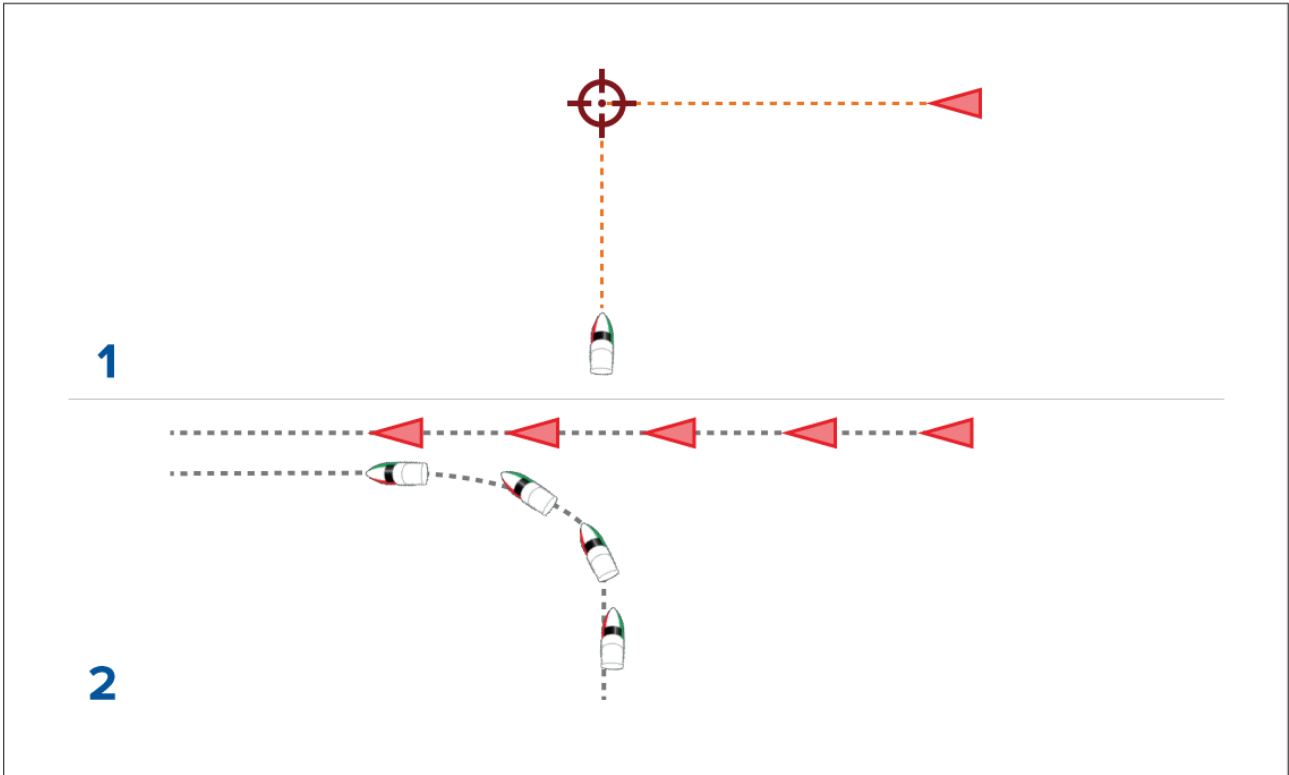

1. Initial Target interception graphics.
2. Actual vessel movements to perform the rendezvous.

8.8 Tides mode

In Tides mode the Tides animation control is displayed onscreen and the Tide station and Current station symbols in the Chart app are replaced with dynamic graphics which identify Tide and Current conditions. You can use the animation controls to play Tide and Current predictions for a 24 hour period. The own vessel Tide vector is also enabled in Tides mode.

Note:

- The Tides mode is only available if you have cartography that provides the Tides and Current data. Refer to your cartography provider for more information.
- The Tides mode requires accurate date information, usually taken from the GNSS (GPS) position data available to your MFD. Alternatively, you can input a specific date manually.

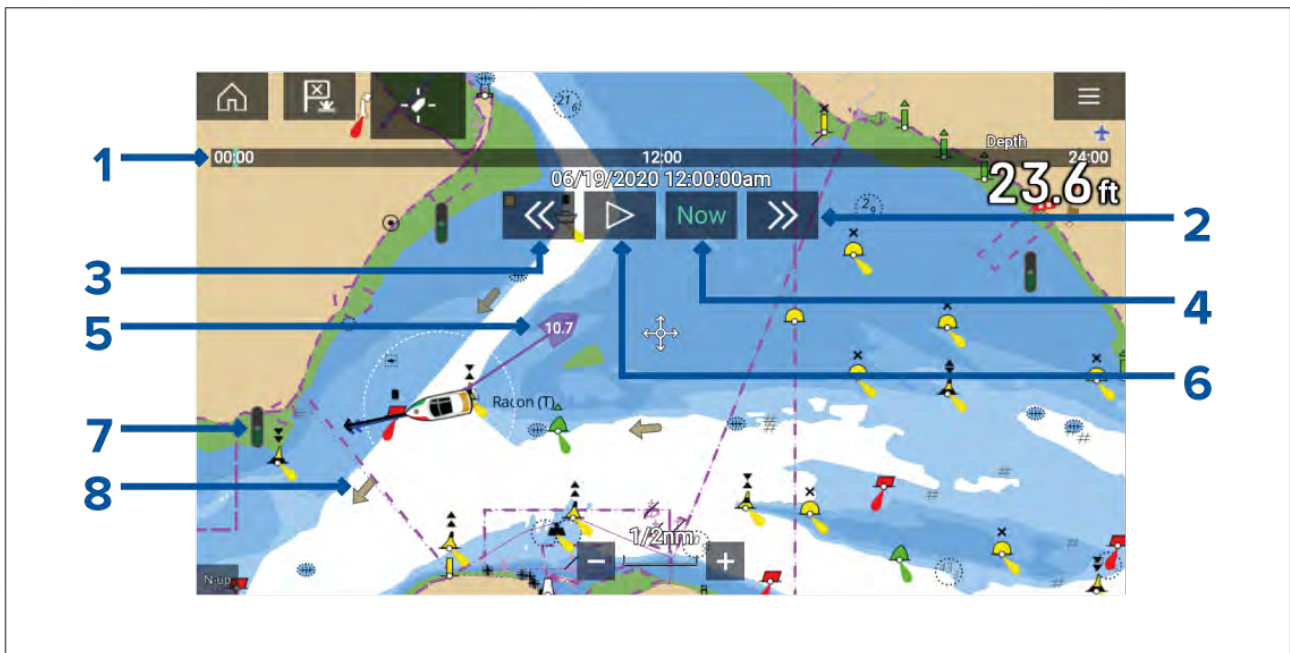

1. Animation progress bar — The progress bar is Blue for the current 24 hour period, or Green when playing animations from a different day.
2. Skip forwards — Skips forwards in user defined intervals, when the end of the progress bar is reached skipping forward will progress to the next day.
3. Skip backwards — Skips backwards in user defined intervals. When the beginning of the progress bar is reached, skipping backward will regress to the previous day.
4. Skip to the actual date / time — Position data is required from your GNSS (GPS) receiver to obtain current date and time.
5. Own vessel tide (Set and Drift) vector.
6. Play / Pause animation — When the animation is playing it will cycle through the current 24 hour period continuously.
7. Dynamic tide height graphic.
8. Dynamic current graphic.

Note:

The data provided in the Tide and Current graphs and graphics is for information purposes only and must NOT be relied upon as a substitute for prudent navigation. Only official government charts and notices to mariners contain all the information needed for safe navigation.

Using animation controls

The animation controls can be selected using the Touchscreen, alternatively you can use the MFD's physical buttons or a RMK controller to control animations as described below:

With the Chart app set to **Tides mode**.

1. Select **Animate tides** from the menu.
2. Use the **Left** button on the Uni-controller to skip forwards in user defined intervals.
3. Use the **Right** button on the Uni-controller to skip backwards in user defined intervals.
4. Use the Uni-controller's **OK** button to Play or Pause the animation.

You can define the User skip time interval from the Advanced menu: **Menu > Settings > Advanced > Tide animation interval**.

Setting a specific date for animations

You can select a specific date for the Tide and Current animation predictions.

1. Select **Select date** from the main menu.
2. Use the **Up** and **Down** arrows to change the date to the required day.
3. Select **Save**.

The animation will be set for the specified date.

Tide station information

When using compatible cartography, Tide station information is available at the location of Tide stations.

Tide station symbol

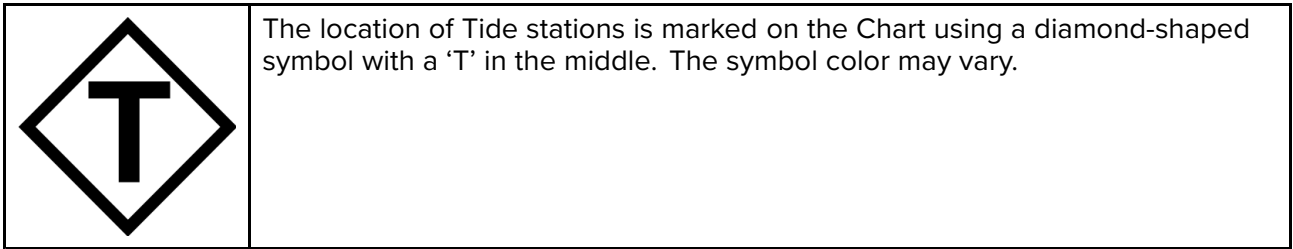

Tide graph

Tide graphs can be accessed by selecting **Tide station** from the Tide station's context menu.

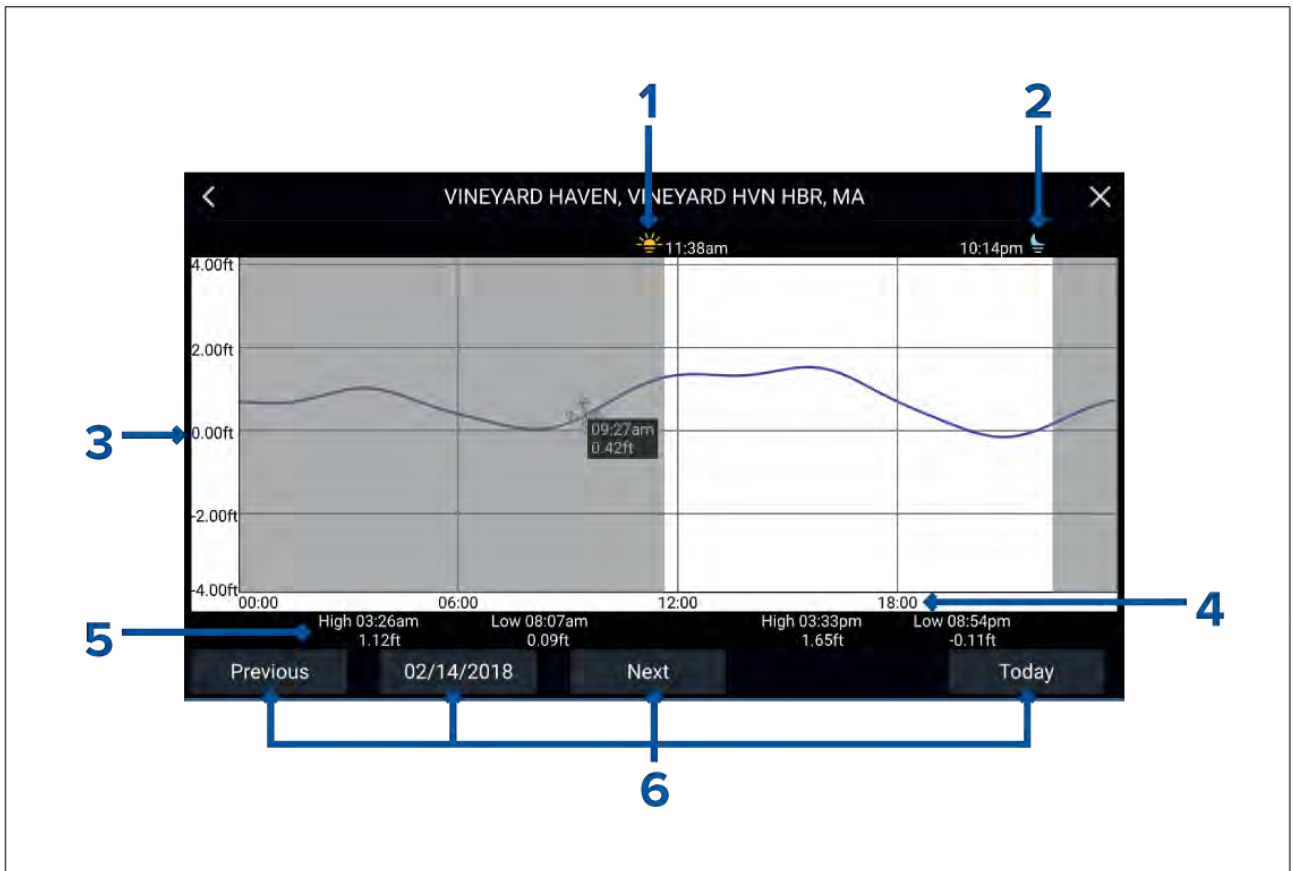

1. **Sunrise** — Indicates time of sunrise.
2. **Sunset** — Indicates time of sunset.
3. **Height** — Provides tide height in selected units.
4. **Time** — Indicates time of day.
5. **Low / High tide** — Indicates the time of low and high tides.
6. **Time and date options** — Use the buttons to view previous, next or today's tide predictions, or enter a date by selecting the date field.

LightHouse charts dynamic tide graphic

When the Tides layer is enabled or when the Chart app is in **Tides mode**, the standard Tide station symbol is replaced with a dynamic Tide height graphic:



1. High tide (Full Green indicator with equals symbol)
2. Decreasing tide (Red decreasing indicator with down arrow)
3. Low tide (Nearly empty Green indicator with equals symbol)
4. Increasing tide (Green indicator with up arrow)

Navionics dynamic tide graphic

When the Tides layer is enabled or when the Chart app is in **Tides mode**, the standard Tide station symbol is replaced with a dynamic Tide height graphic:

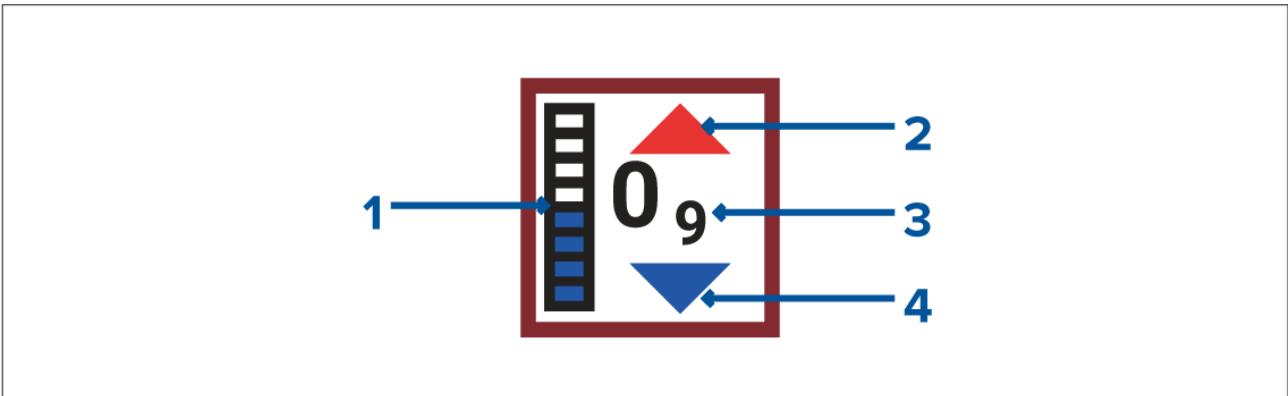

1. Tide bar — The tide bar plots the current tide height against the maximum predicted tide height for that day.
2. Red arrow indicates tide height is increasing.
3. Tide height — Tide height is displayed in user-selected depth units, with decimals displayed in subscript. Decimals are not shown for values of 10 or greater.
4. Blue arrow indicates tide height is decreasing.

Current station information

Depending on your cartography, Current station information may be available at the location of Current stations.

Current station symbol

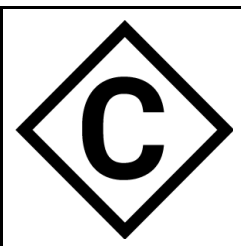

The location of Current stations is marked on the Chart using a diamond-shaped symbol with a 'C' in the middle. The symbol color may vary.

Current graph

Current graphs can be accessed by selecting **Current station** from the Current station's context menu.

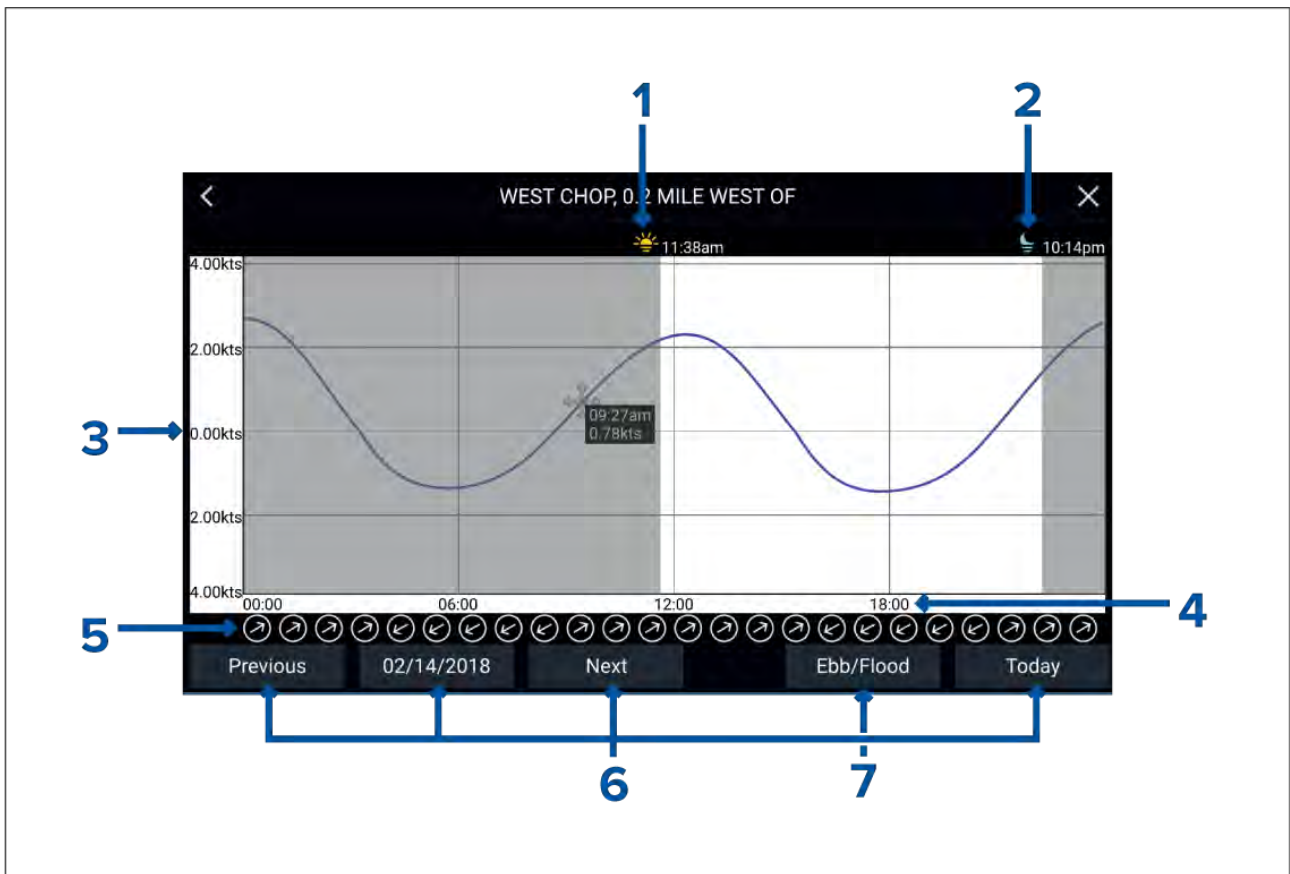

1. **Sunrise** — Indicates time of sunrise.
2. **Sunset** — Indicates time of sunset.
3. **Speed** — Provides current speed in selected units.
4. **Time** — Indicates time of day.
5. **Direction** — Indicates the direction of the current (relative to North).
6. **Time and date options** — Use the buttons to view previous, next or today's tide predictions, or enter a date by selecting the date field.
7. **Ebb / Flood** — Displays a list showing ebb, slack and flood tides.

LightHouse Charts dynamic current graphic

When the Tides layer is enabled or when the Chart app is in **Tides mode**, the standard Current station symbol is replaced with a dynamic Current graphic. Arrows are used to indicate the direction of current flow. The size and color of the arrow indicates the strength of the current:

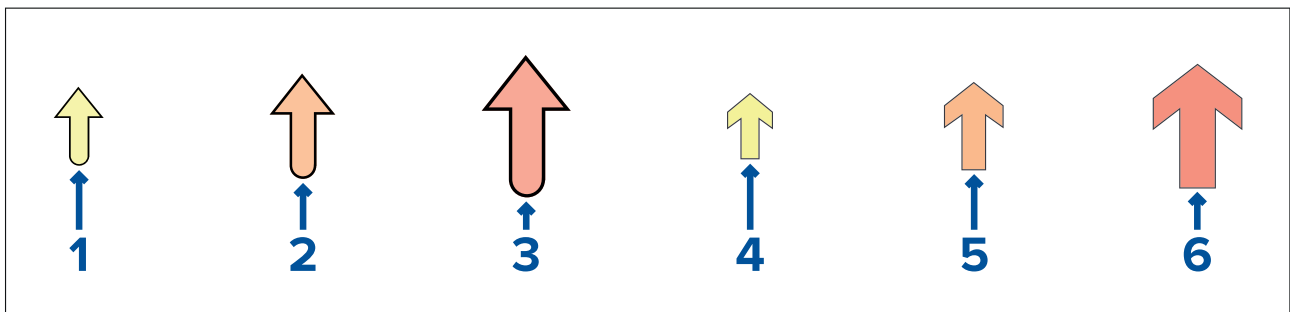

1. Yellow small arrow: 0 Knots to 1.0 Knots (Leisure chart style)
2. Orange medium arrow: 1.1 Knots to 2.0 Knots (Leisure chart style)
3. Red large arrow: Greater than 2.0 Knots (Leisure chart style)
4. Yellow small arrow: 0 Knots to 1.0 Knots (Government chart style)
5. Orange medium arrow: 1.1 Knots to 2.0 Knots (Government chart style)
6. Red large arrow: Greater than 2.0 Knots (Government chart style)

C-Map dynamic current graphic

When the Tides layer is enabled or when the Chart app is in **Tides mode**, the standard Current station symbol is replaced with a dynamic Current graphic. Arrows are used to indicate the direction of current flow. The size and color of the arrow indicates the strength of the current:

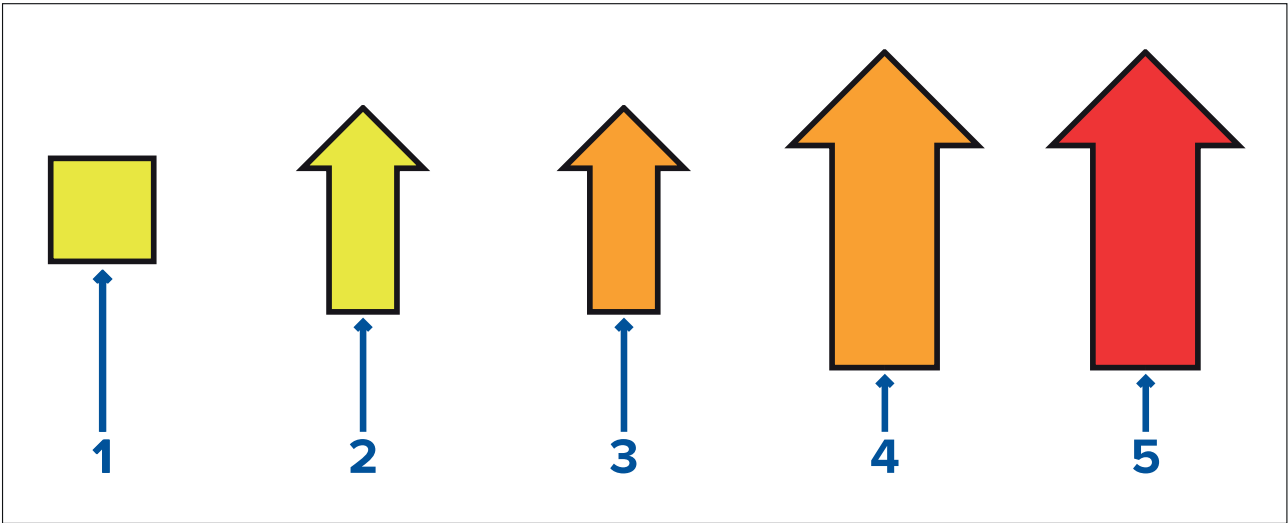

1. Yellow square: 0 Knots to 0.1 Knots
2. Yellow small arrow: 0.2 Knots to 1.0 Knots
3. Orange small arrow: 1.1 Knots to 2.0 Knots
4. Orange large arrow: 2.1 Knots to 3.0 Knots
5. Red large arrow: Greater than 3.0 Knots

Navionics dynamic current graphic

When the Tides layer is enabled or when the Chart app is in **Tides mode**, the standard Current station symbol is replaced with a dynamic Current graphic. Arrows are used to indicate the direction of current flow.

The length of the arrow indicates the speed of the current; the longer the arrow, the faster the speed. The border color of the arrow indicates increasing or decreasing speed.

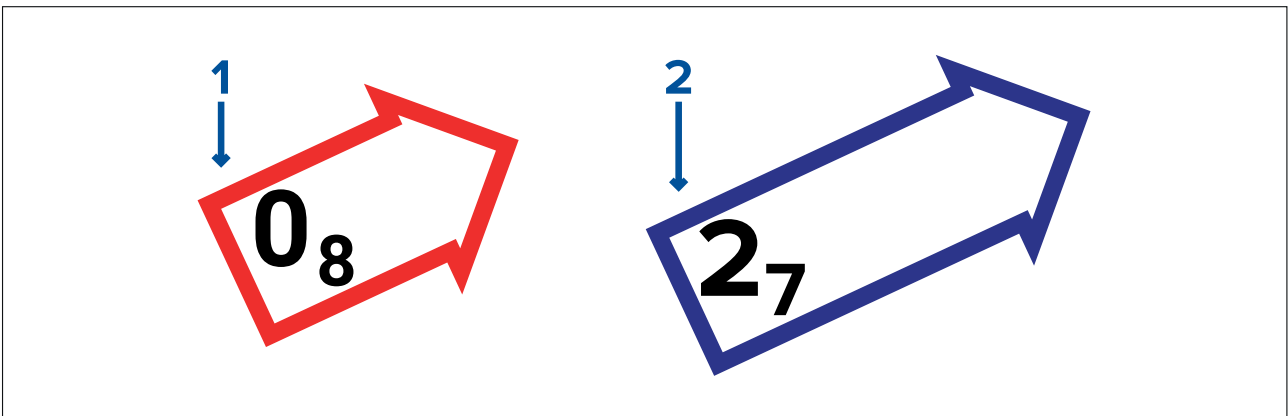

1. **Red** = increasing current speed.
2. **Blue** = decreasing current speed.

Current speed is shown inside the arrow. Current speed is displayed in user-selected speed units, with decimals displayed in subscript. Decimals are not shown for values of 10 or greater.

If tidal conditions are “slack”, the word “SLACK” appears in a box with a Blue border.

Displaying tide or current graphs

1. Select a tide or current station symbol or dynamic graphic.
2. Select **more options** from the context menu.
3. Select **Tide station** or **Current station**

Note:

You can also access tide and current graphs by selecting **More info** from the pop-over options when performing a **Find nearest** search for tides.

8.9 RealBathy™

You can create precise personal bathymetric charts in realtime using Raymarine's RealBathy™ feature. When using the RealBathy™ feature, new contour lines are drawn in realtime on the screen based on your transducer's depth readings. Color shading is used to reflect depth, with the darkest shades signifying the shallowest area. The sonar data is recorded to the inserted memory card.

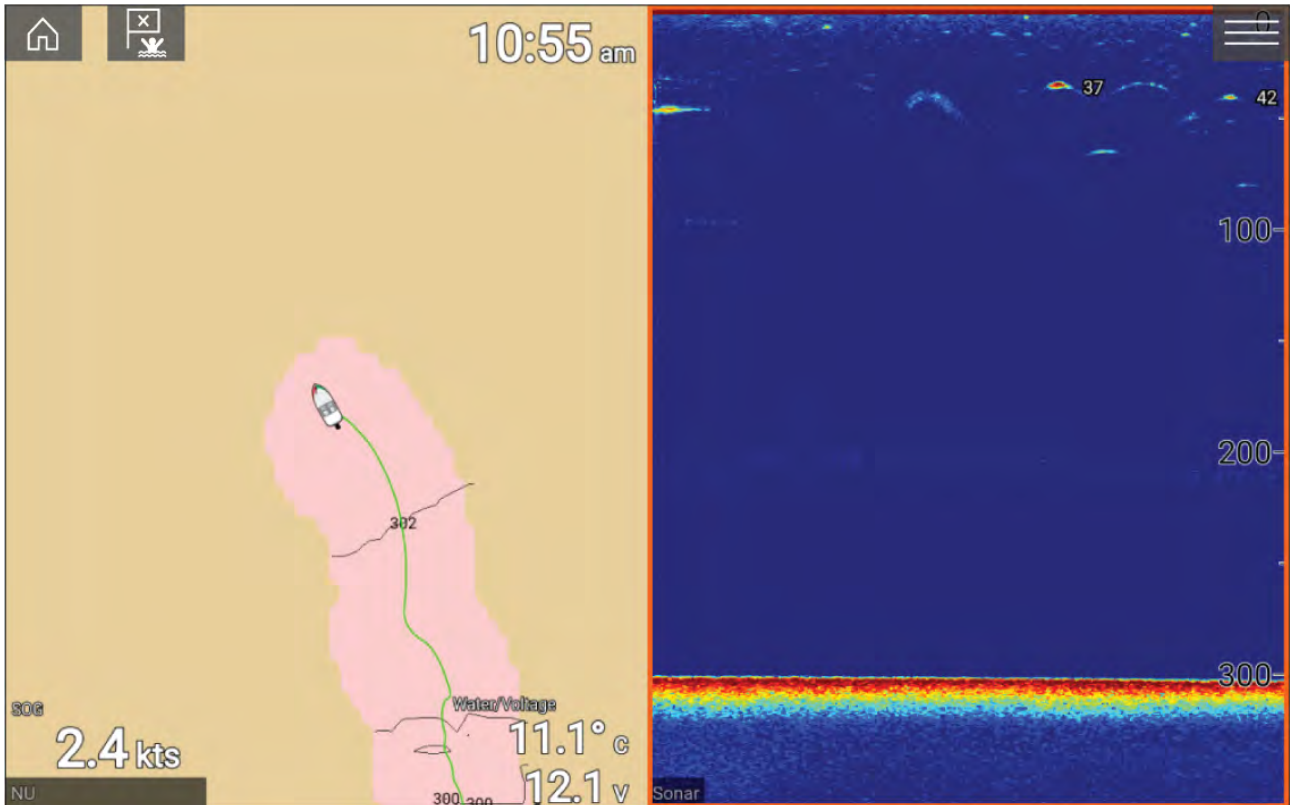

Requirements

The Realbathy feature requires the following:

- LightHouse™ software version 3.9 or later.
- LightHouse™ vector based charts, that include tide station information for the location you wish to survey.
- MicroSD card with sufficient free space to record depth and bathymetry data.
- You must ascertain the distance above the bottom face of your depth transducer to the waterline, as shown in the following illustration:

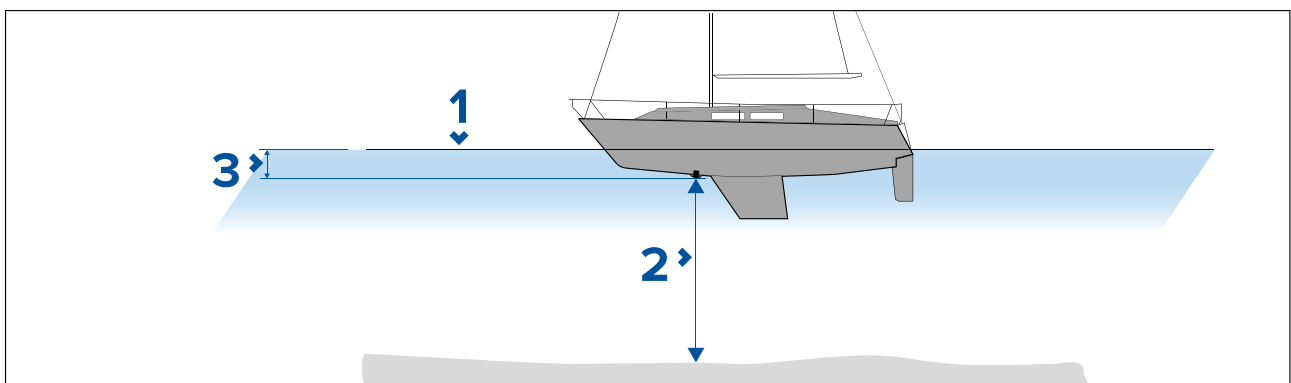

1. Waterline.
2. Water depth below transducer face.

- Distance above the bottom face of your depth transducer to the waterline.

Setting up and creating RealBathy contours

Important:

- You will need to know the distance above the bottom face of your transducer to the waterline.
- For tidal environments, ensure you have LightHouse™ NC2 cartography that includes tide station information for your location.

From the chart app.

- Insert your LightHouse™ NC2 chart card into the display's card reader.
- Select your LightHouse™ chart card as your cartography for the chart app.

For details on choosing your cartography refer to: [Selecting a chart card](#)

- Enter the distance above the bottom face of your transducer to the waterline in the **Waterline to tdc**: setting field.
- Enable the **RealBathy** toggle switch, located in the **Depths** menu: **Menu > Depths**
- Select the relevant **Height correction** option:
 - None** — No corrections are made.
 - Tidal** — Uses nearby tide station data to correct height. When **Tidal** is selected a tidal station search is performed and a list of available stations is displayed. Select the closest tide station to your location.
 - Lake level** — User specified value using the water level marker for your location.

Note:

To ensure accurate contour depths it is recommended that:

- in tidal environments (for example, seas and oceans) you use LightHouse™ NC2 cartography that includes tide station information and select the tide station closest to your location;
- in fresh water environments (for example, lakes), select **Lake level** in the **Height correction**: field and then enter the current reading from the water level marker for your location into the field located under the height correction option.

- Adjust the **Visibility**: setting to the desired transparency.

100% provides full visibility of the RealBathy contours; as the percentage decreases the chart detail behind the RealBathy contours becomes more visible.

- Select the required **Density**: setting.

Steep drop-offs can result in overlapping contour lines; lowering the density in these situations provides a clearer view.

8.10 Find nearest

The Find nearest feature allows you to select a target or location and search for nearby objects or places.

Note:

- The level of detail available on charts is dependent on vendor, chart type, subscription level and geographic region. Prior to purchasing charts check the vendor's website to establish what level of detail is available on the charts you want to purchase.
- The information relating to available chart detail and settings in this manual should be treated as guidance only as it is subject to change that is not under Raymarine's control.

When an object is selected, the **Nearby objects** option is available from the object context menu.

Object selection find nearest

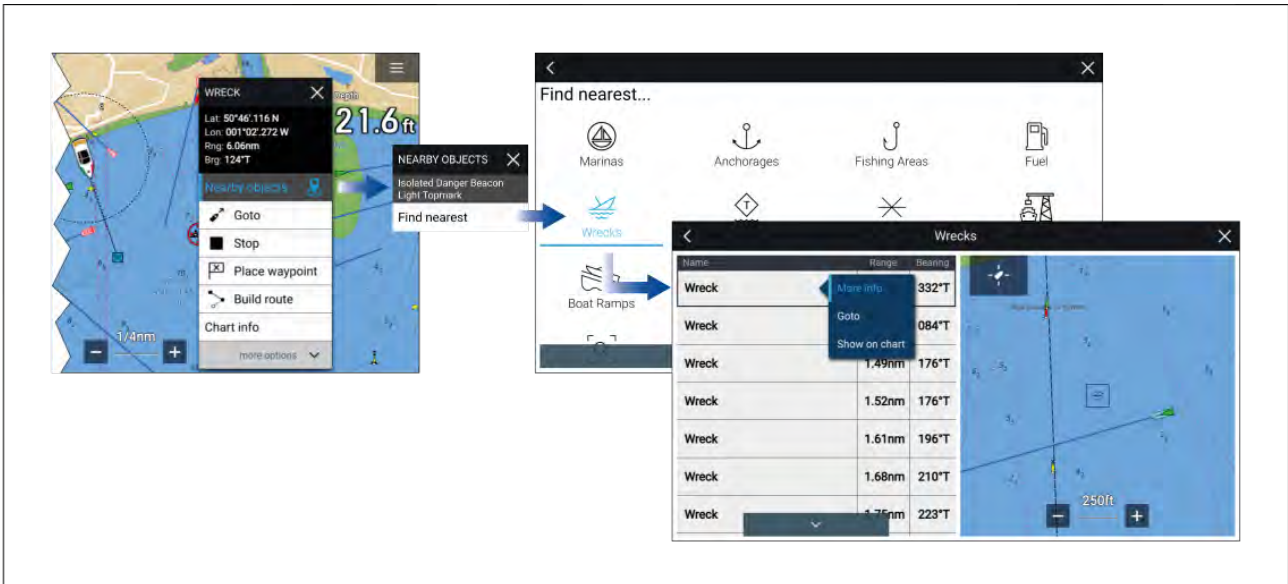

Selecting **Nearby objects** and then **Find Nearest** will display the Find nearest options page where you can select the type of place or object you want to search for.

Selecting an option will display a list of all nearby objects for that type. The list is sorted by an object's proximity to the selected location. However, the Range and Bearing displayed is relative to your vessel's position.

Location selection find nearest

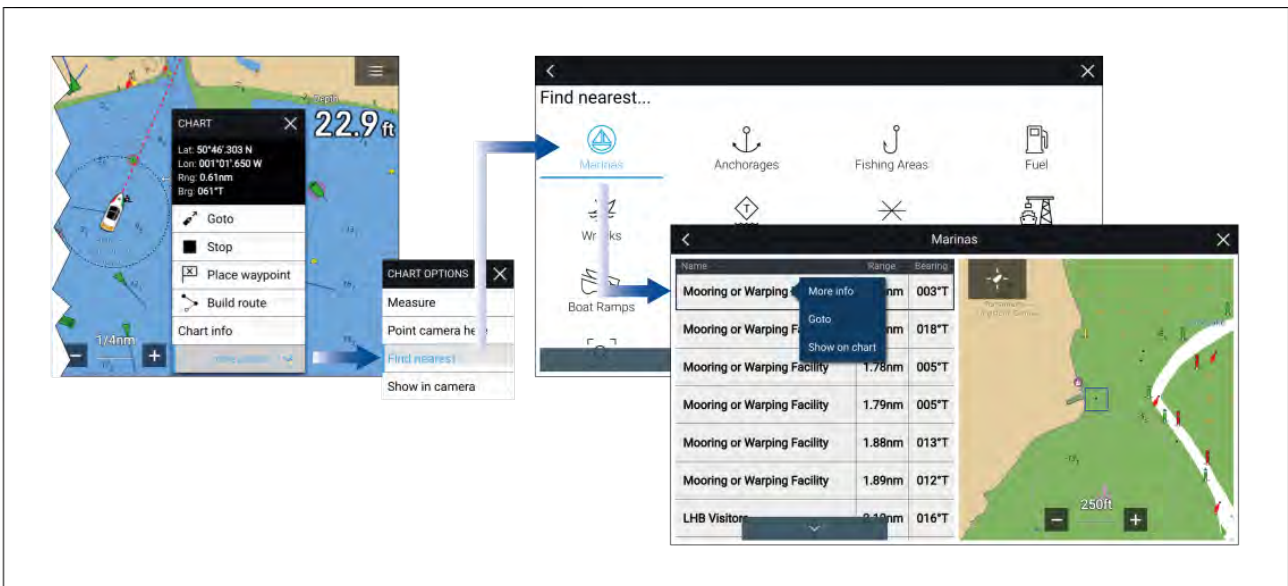

Pressing and holding on a location will open the Chart context menu, selecting **more options** and then **Find nearest** will display the Find nearest options page where you can select the type of place or object you want to search for.

Selecting an option will display a list of all nearby objects for that type. The list is sorted by an object's proximity to the selected location. However, the Range and Bearing displayed is relative to your vessel's position.

Find nearest options

Note:

Legacy LightHouse Charts refers to retired LightHouse vector, raster and NC2 Charts.

The options available on the find nearest page depend on the cartography type you are using:

- **Marinas** (LightHouse Charts, Navionics and C-Map)
- **Anchorages** (LightHouse Charts)
- **Fishing Areas** (LightHouse Charts)

- **Fuel** (LightHouse Charts)
- **Wrecks** (LightHouse Charts, Legacy LightHouse Charts, Navionics and C-Map)
- **Tides** (Legacy LightHouse Charts, Navionics and C-Map)
- **Currents** (Legacy LightHouse Charts, Navionics and C-Map)
- **Lakes** (Navionics and C-Map)
- **Obstructions** (LightHouse Charts, Legacy LightHouse Charts, Navionics and C-Map)
- **Ports/Services** (LightHouse Charts, Navionics and C-Map)
- **Boat Ramps** (LightHouse Charts)
- **Food & Drink** (LightHouse Charts)
- **Toilets** (LightHouse Charts)
- **Beach/Swim/Recreation** (LightHouse Charts)
- **Search for port** (LightHouse Charts, Legacy LightHouse Charts, Navionics, C-Map)
- **Small Craft Facility** (Legacy LightHouse Charts)
- **Harbor Facility** (Legacy LightHouse Charts)
- **Businesses** (Navionics)
- **Point of interest** (C-Map)
- **Outdoor Recreational Areas (ORA)** (C-Map)
- **ORA Services** (C-Map)

List options

From the list of found objects or places the following pop-over options are available for each item in the list:

- View more information about the object by selecting **More info**.
- Navigate to the selected object by selecting **Goto**.
- Create an automatic route to the selected object by selecting **Autoroute to**, if available.
- Display the selected object in the Chart app by selecting **Show on chart**.

When an item from the list is selected the **LiveView** on the right of the screen will highlight and zoom to the selected object.

8.11 Measure

The Measure feature can be used to measure distances from your vessel or distances between 2 points.

The measure feature is available from the Chart context menu: **Context menu > more options > Measure**.

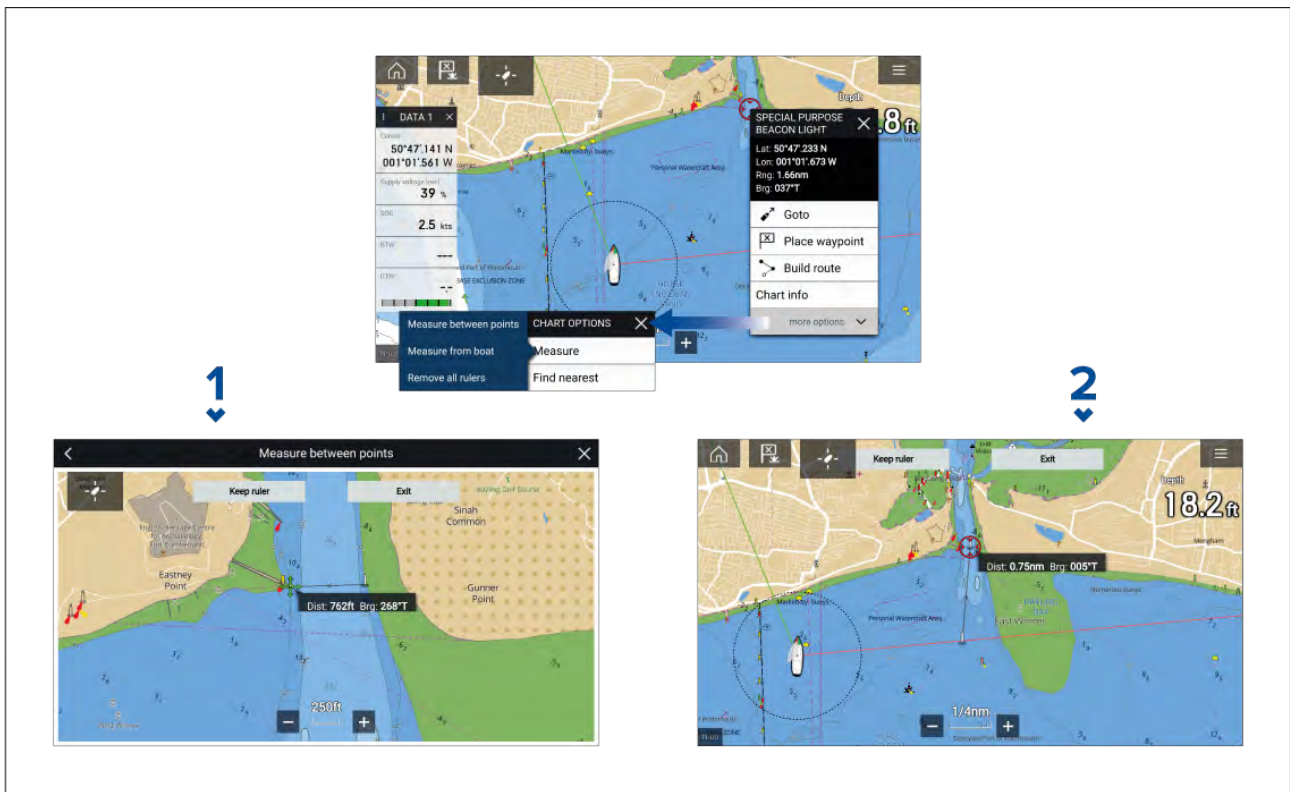

1. Point to point ruler.
2. Vessel to point ruler.

Multiple rulers can be created and displayed simultaneously.

Measuring vessel to point

To measure the distance and bearing of a location from your vessel's location follow the steps below.

1. Select (press and hold) on the required location.
The context menu is displayed.
2. Select **more options**.
3. Select **Measure**.
4. Select **Measure form boat** from the pop-over options.
A ruler line is drawn on the screen from your vessel's location to the cursor's location. The distance and bearing from your vessel is also displayed in an information box.
5. If you would like to keep the ruler line select **Keep ruler** from the top of the screen.
The ruler will be permanently displayed onscreen, the vessel end of the ruler will move with your vessel updating distance and bearing as you travel.
6. If you do not want to keep the ruler select **Exit** from the top of the screen and select **Discard** from the confirmation dialog.

Measuring point to point

To measure the distance between 2 points and bearing to the first point follow the steps below.

1. Select (press and hold) any location on the screen.
The context menu is displayed.
2. Select **more options**.
3. Select **Measure**.
4. Select **Measure between points** from the pop-over options.
5. Select the location for the first point.
6. Select the location for the second point.
7. If you would like to keep the ruler line select **Keep ruler** from the top of the screen.
The ruler will be permanently displayed onscreen.
8. If you do not want to keep the ruler select **Exit** from the top of the screen and select **Discard** from the confirmation dialog.

Deleting rulers

You can delete individual rulers or all rulers at the same time.

1. Select (press and hold) on a ruler point.
2. Select **Delete ruler** from the context menu.

Alternatively you can delete all rulers by selecting **Remove all rulers** from the context menu.

8.12 SAR (Search and Rescue) patterns

Attempting to search the water for an object can be challenging, due to the vastness of the ocean and the effects of tide. Additionally, the object you are searching for is not normally in its last known location.

SAR Patterns are routes that can help you find an object in the water. The pattern can be modified and can take the effects of the tide into account, providing a more accurate and consistent route to search. SAR Patterns can be created on your MFD in the **Chart app**.

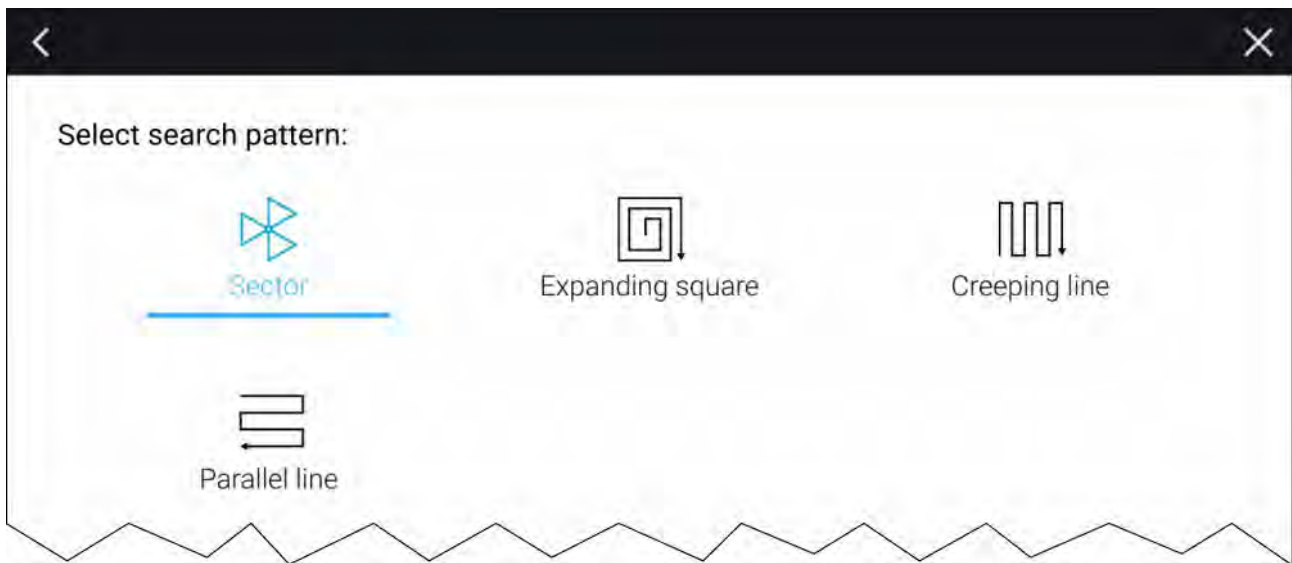

Access search pattern options: **Chart app > Menu > New > Search patterns**.

The available Search Patterns are:

- Sector Search
- Expanding square
- Creeping line
- Parallel Line

Once a search pattern is created it is saved as a Route and can be managed and navigated in the same manner as any other saved Route. For more information refer to: [7.2 Routes](#)

When the MFD is configured using the 'First responder' boating activity profile SAR patterns can be received over STEDS messaging. For more information refer to: [9.8 SAR pattern receipt](#)

Sector search pattern

The Sector Search pattern is made up of 9 legs, with the 3rd, 6th and 9th leg running past the datum (the Track Spacing will change depending on whether you are with or against the drift).

Note: As the Search patterns take in to account drift, the resulting Route may not resemble the patterns shown.

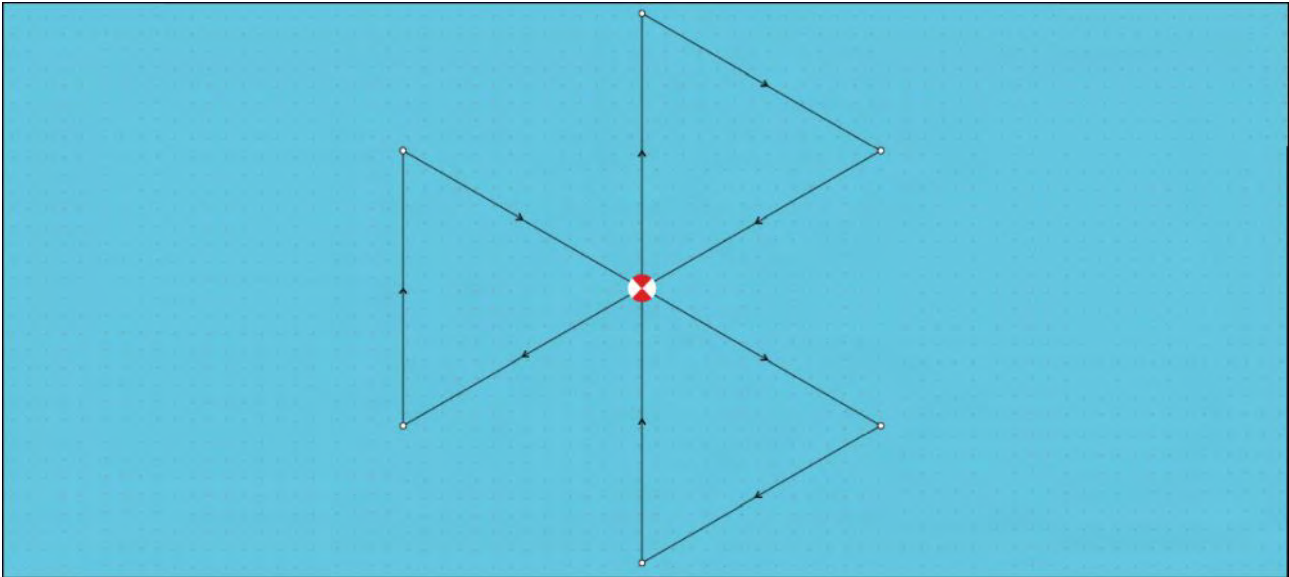

Creating a sector search pattern

To create a Sector Search pattern follow the steps below:

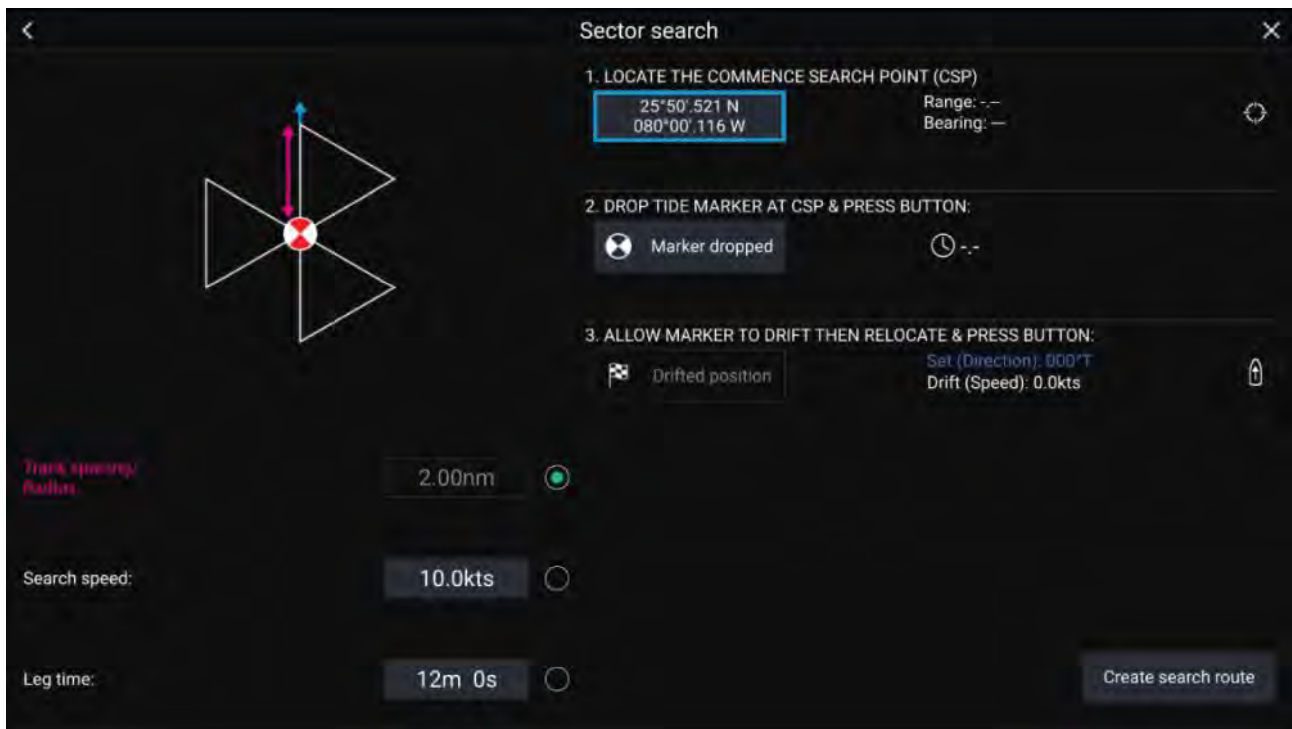

1. Set Commence Search Point (CSP)

- i. Manually input the **CSP** coordinates; a **Range** and **Bearing** are displayed to direct your vessel towards it.
- ii. Alternatively, set the **CSP** as your vessel's current location by selecting the ⁽¹⁾ **CSP Shortcut** button.

2. Set Drift

- i. Drop the **Datum Marker** in the water and select **Marker dropped**.
- ii. Wait for the **Datum Marker** to drift through the water.
- iii. Return to the **Datum Marker** in the new location and select **Drift position** to calculate the **Set (Direction)** and **Drift (Speed)**.
- iv. Alternatively, you can use your vessel's **Heading** and **SOG** to define the set and drift by selecting the ⁽²⁾ **Set / Drift shortcut** icon.

3. Set Track spacing / Radius, Search Speed, and Leg time

[All 3 variables are dependent on each other. One variable is always the product of the other two.]

- i. Select one of the variables by selecting the ⁽³⁾ **Output** icon.

- ii. The selected variable will then be calculated as a result of changes made to the other two variables.

Variable	Maximum Value
Track spacing / Radius	5 nm / 5 sm / 5 Km
Search Speed	40 Kts / 46 Mph / 74 Kph
Leg Time	59m 59s

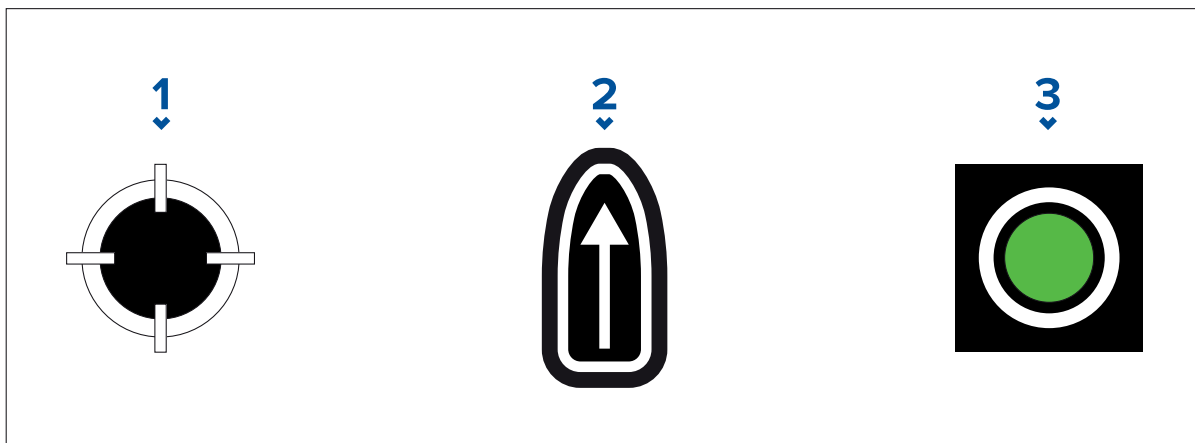

1. **CSP Shortcut**
2. **Set / Drift Shortcut**
3. **Output**

4. **Create search route**

[After all the above steps have been completed you can create your SAR pattern.]

- i. To create a search pattern, select the **Create search route** button in the bottom right of the screen.
- ii. The creation page will display your SAR pattern data and its location on the Chart app.

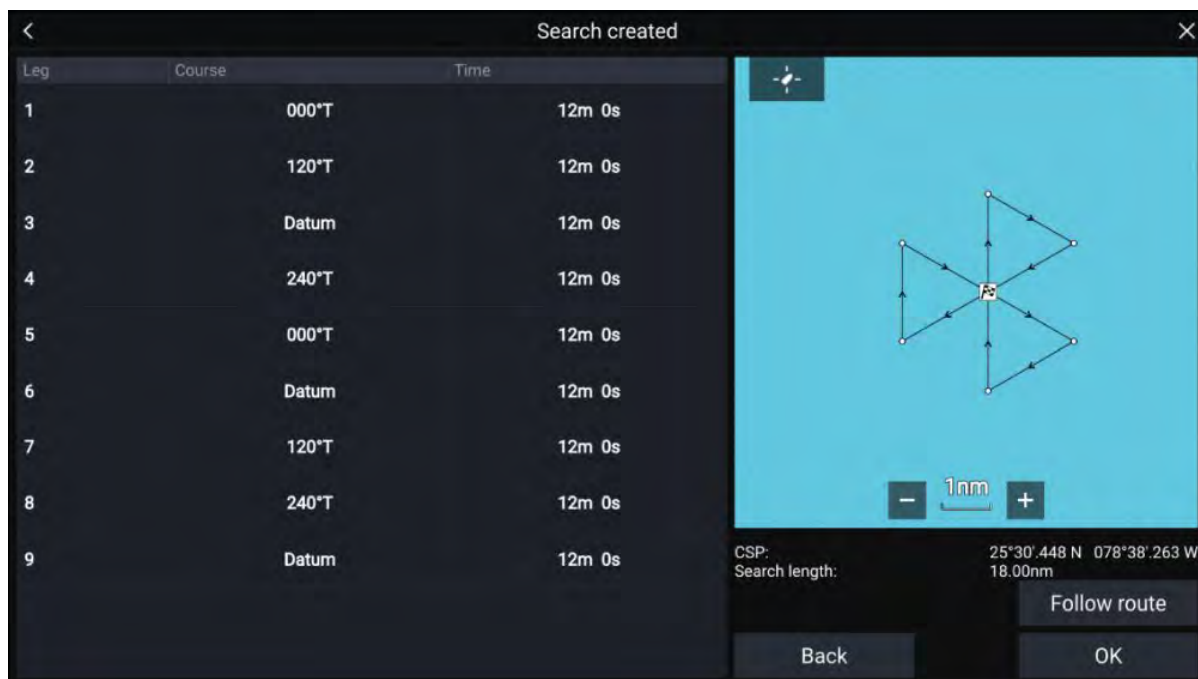

- iii. Select **Follow Route** to overlay the pattern on the **Chart app** and automatically follow the route.
- iv. Alternatively, select **OK** to overlay the pattern on the **Chart app** without following it.

Drift effects on sector search patterns

As the search patterns account for drift the resulting **Route** may not resemble the pattern shown above.

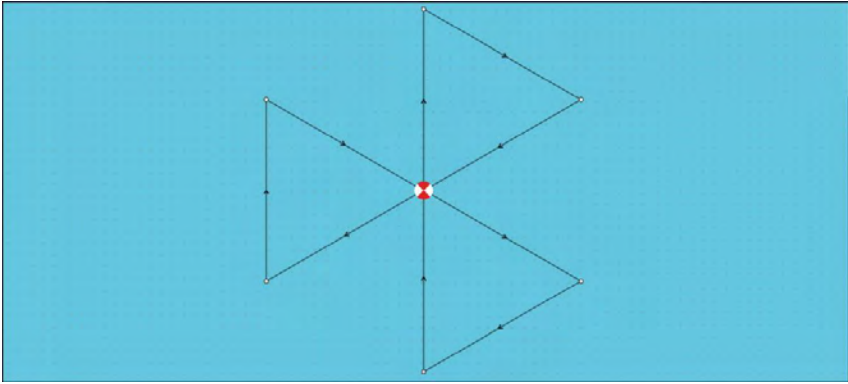
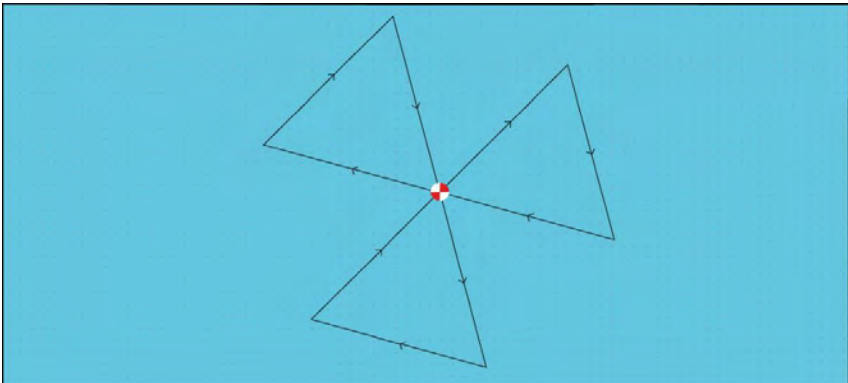
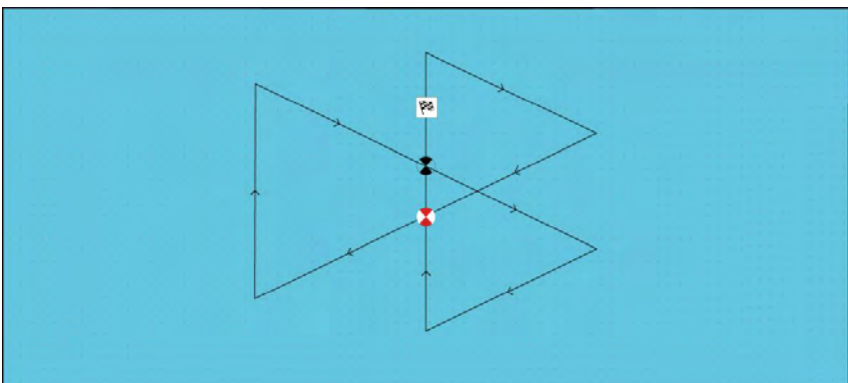
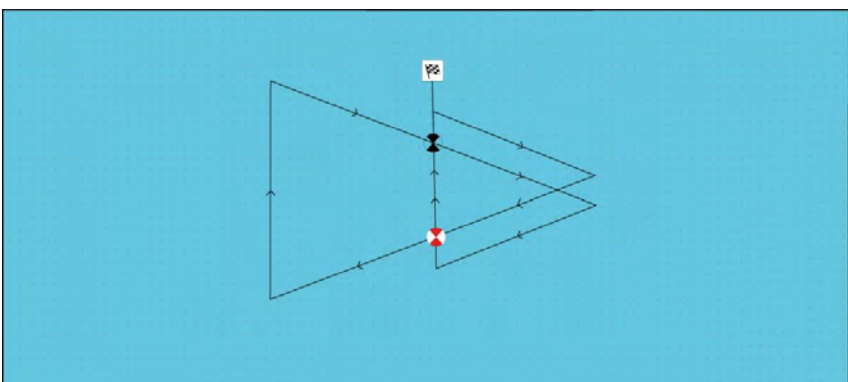
Example	Drift
	Direction: 0° Speed: 0 Kts
	Direction: 45° Speed: 0 Kts
	Direction: 0° Speed: 0.5 Kts
	Direction: 0° Speed: 1 Kts

Expanding square search pattern

The Expanding Square search pattern is an outwards spiralling square pattern, and is particularly suited to very detailed and methodical searches.

Note:

The Search patterns take drift into account, and therefore the resulting route may not resemble the patterns shown.

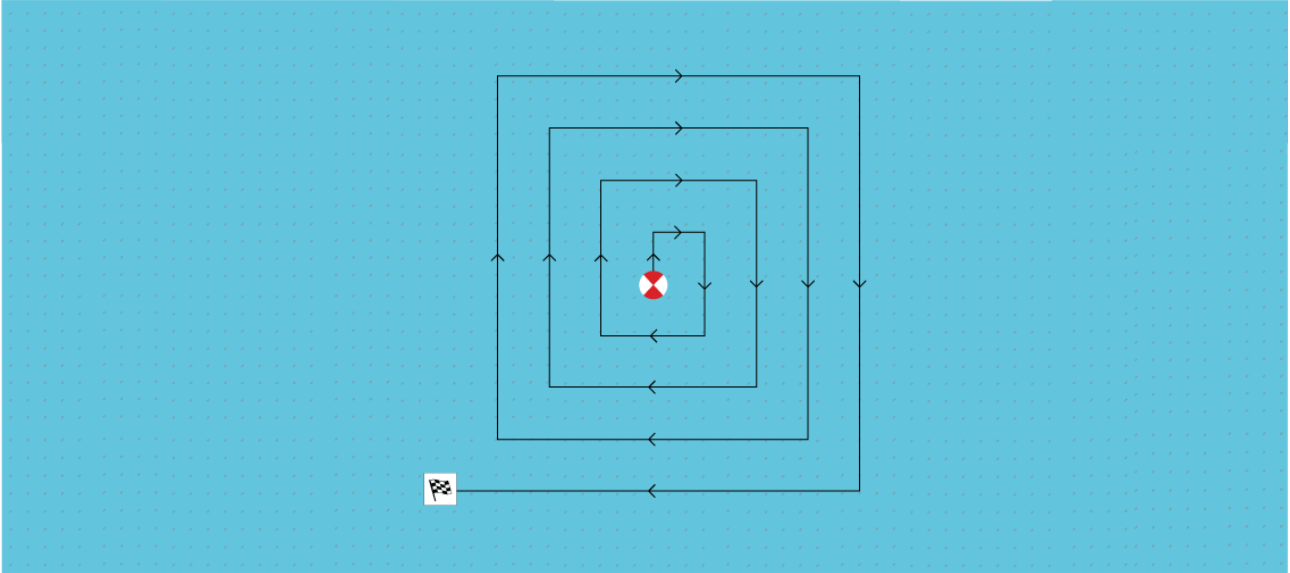

Creating an expanding square search pattern

To create a Expanding Square search pattern follow the steps below:

Expanding square search

1. LOCATE THE COMMENCE SEARCH POINT (CSP)

25°41'.408 N
080°13'.132 W

Range: 346ft
Bearing: 180°T

2. DROP TIDE MARKER AT CSP & PRESS BUTTON:

Marker dropped

3. ALLOW MARKER TO DRIFT THEN RELOCATE & PRESS BUTTON:

Drifted position

Set (Direction): 000°T
Drift (Speed): 0.0kts

Track spacing: 0.5nm

Search speed: 6.0kts

Leg time: 5m 0s

Number of Legs: 7

Create search route

1. Set Commence Search Point (CSP)

- Manually input the **CSP** coordinates; a **Range** and **Bearing** are displayed to direct your vessel towards it.
- Alternatively, set the **CSP** as your vessel's current location by selecting the ⁽¹⁾ **CSP Shortcut** button.

2. Set Drift

- Drop the **Datum Marker** in the water and select **Marker dropped**.
- Wait for the **Datum Marker** to drift through the water.

- iii. Return to the **Datum Marker** in the new location and select **Drift position** to calculate the **Set (Direction)** and **Drift (Speed)**.
- iv. Alternatively, you can use your vessel's **Heading** and **SOG** to define the set and drift by selecting the ⁽²⁾ **Set / Drift shortcut** icon.

3. **Set Track spacing / Radius, Search Speed, and Leg time**

[All 3 variables are dependent on each other. One variable is always the product of the other two.]

- i. Select one of the variables by selecting the ⁽³⁾ **Output** icon.
- ii. The selected variable will then be calculated as a result of changes made to the other two variables.

Variable	Maximum Value
Track spacing / Radius	5 nm / 5 sm / 5 Km
Search Speed	40 Kts / 46 Mph / 74 Kph
Leg Time	59m 59s

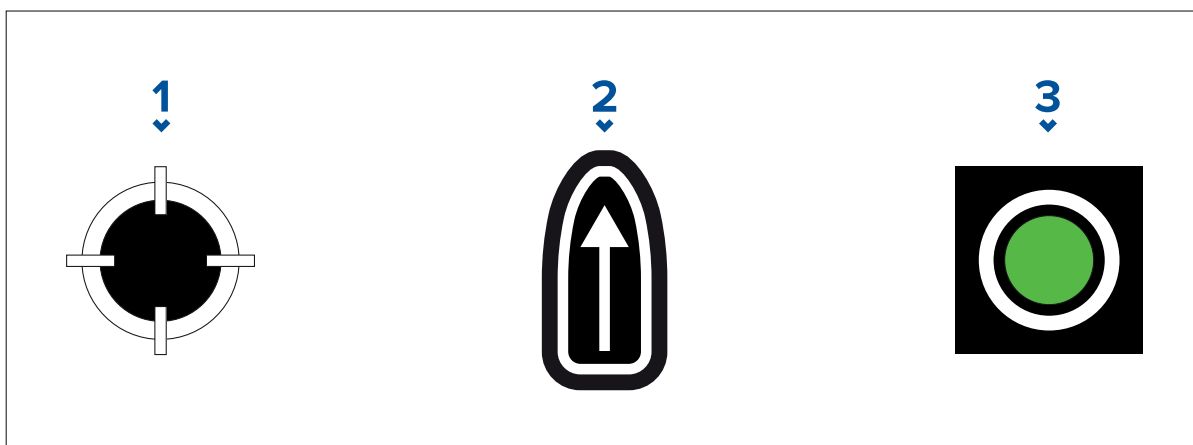

- 1. **CSP Shortcut**
- 2. **Set / Drift Shortcut**
- 3. **Output**

4. **Set the number of legs**

- i. Select the number of legs for your expanding square search pattern.

5. **Create search route**

[After all the above steps have been completed you can create your SAR pattern.]

- i. To create a search pattern, select **Create search route** in the bottom right of the screen.
- ii. The creation page will display your SAR pattern data and its location in the Chart app.

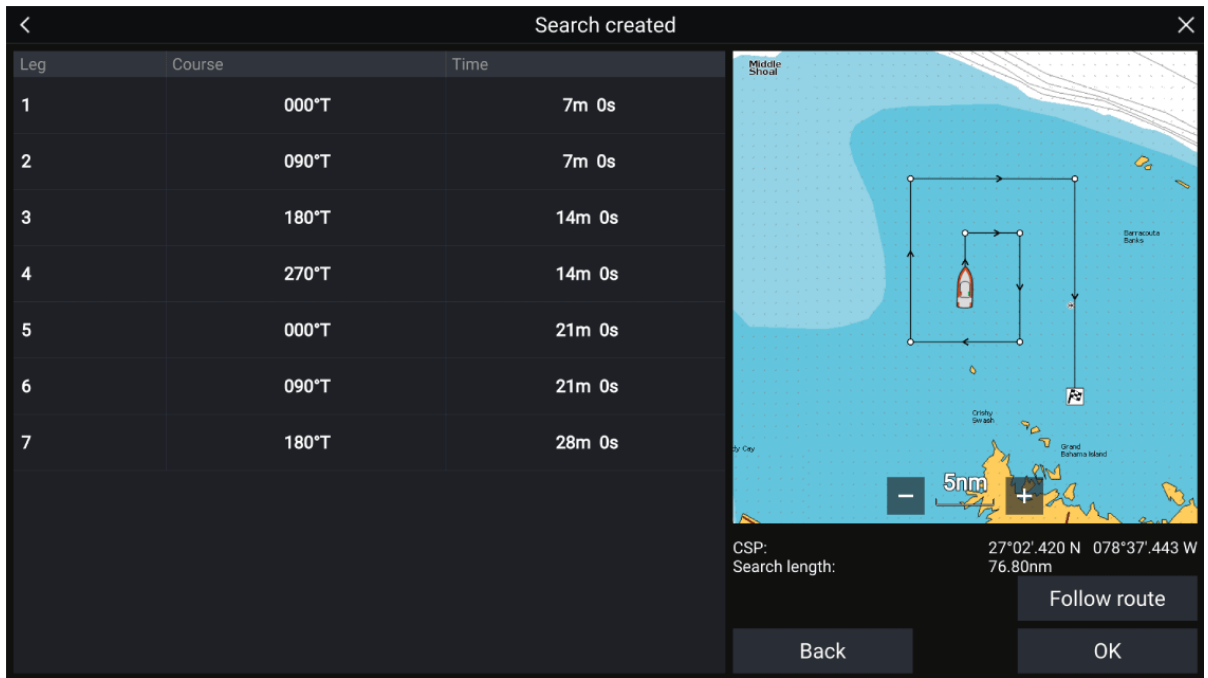

- iii. Select **Follow Route** to overlay the pattern on the Chart app and automatically follow the route.
- iv. Alternatively, select **OK** to overlay the pattern on the Chart app without following it.

Drift effects on expanding square search patterns

As the search patterns account for drift the resulting **Route** may not resemble the pattern shown above.

Example	Drift
	Direction: 0° Speed: 0 Kts
	Direction: 45° Speed: 0 Kts

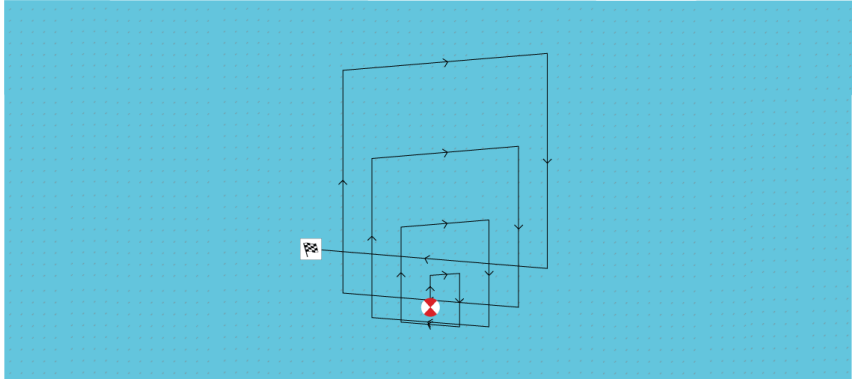
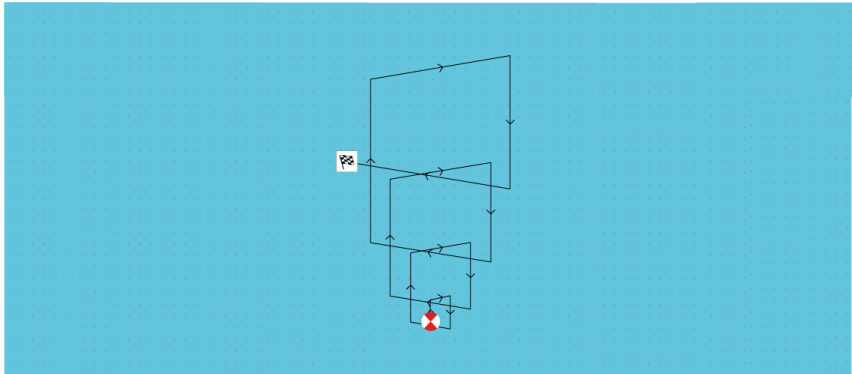
Example	Drift
	Direction: 0° Speed: 0.5 Kts
	Direction: 0° Speed: 1 Kts

Creeping line / Parallel line search pattern

The **Creeping / Parallel Line search pattern** covers a rectangular area. The area is searched either by starting at one end of the search area (Creeping), which provides greater coverage of one end but will take time to cover the whole area, or by searching the area lengthways (Parallel). This provides reasonable coverage of the area quickly.

The Creeping Line search should be used when there is a logical end of the search area to start your search from.

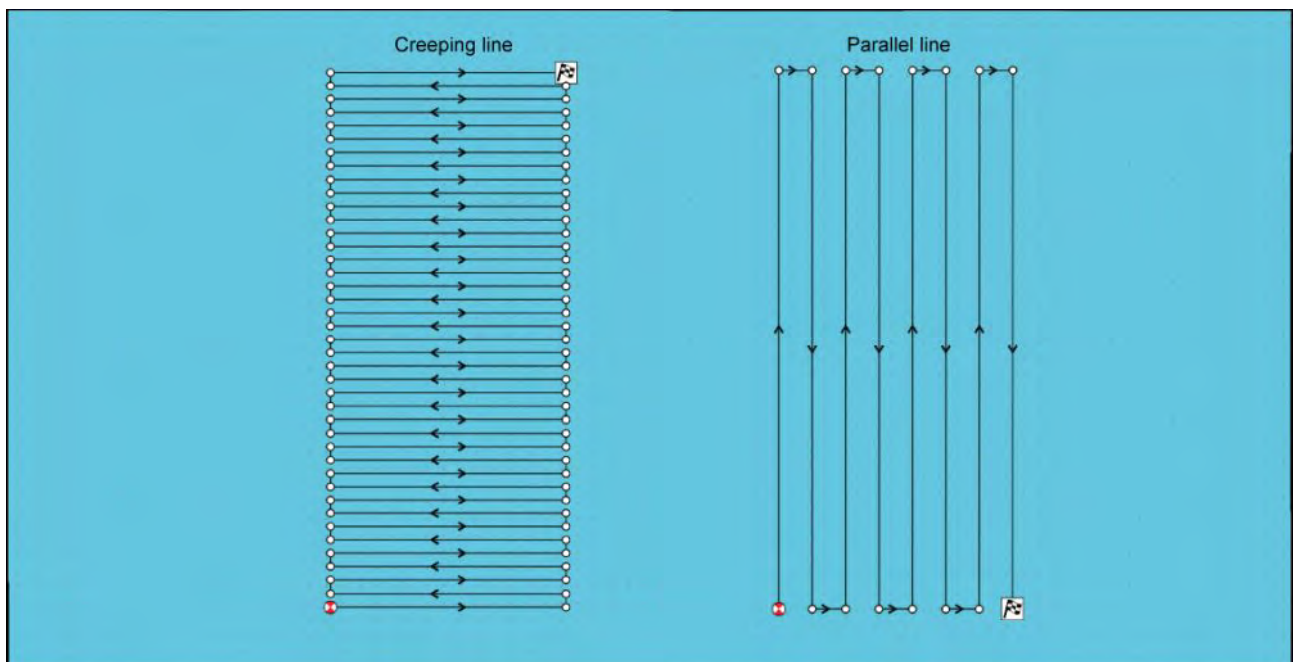

Creating a Creeping line / Parallel line search pattern

To create a Creeping line / Parallel line search pattern follow the steps below:

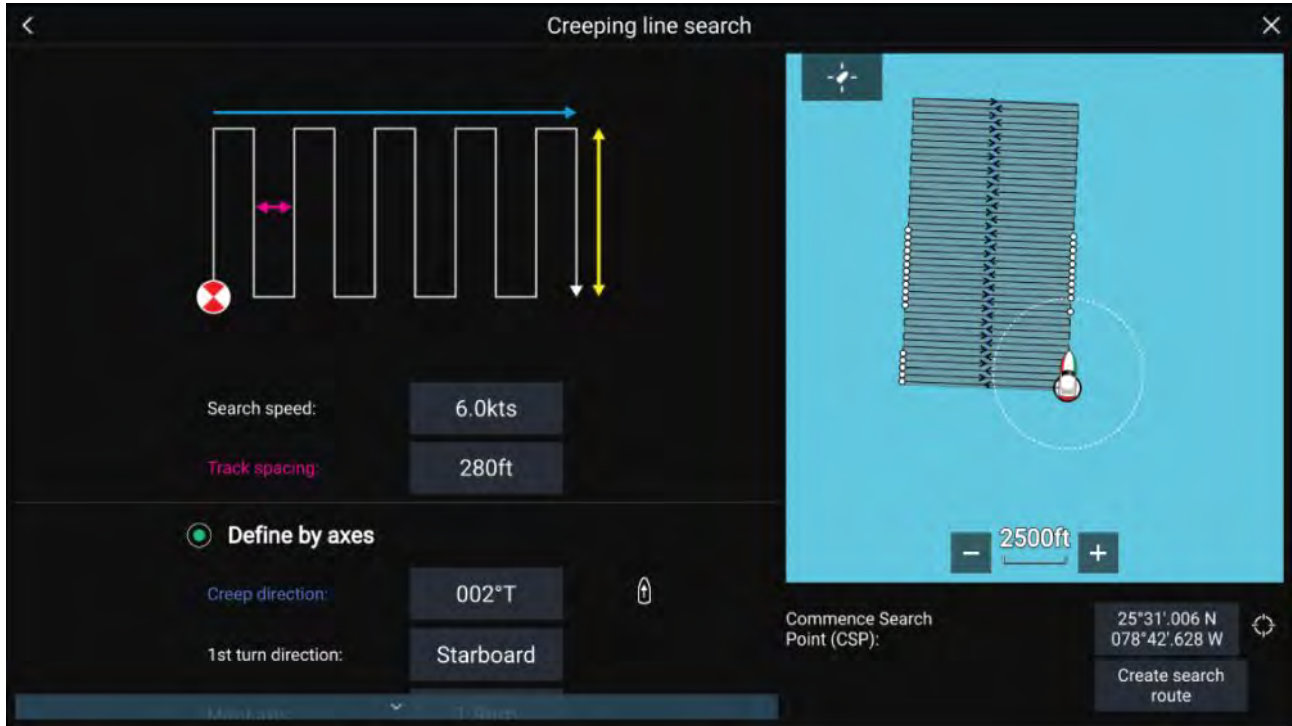

1. **Set Commence Search Point (CSP)**
 - i. Manually input the **CSP** coordinates.
 - ii. Alternatively, set the **CSP** as your vessel's current location by pressing the ⁽¹⁾ **CSP Shortcut** button.
2. **Set Search Speed, and Track Spacing**
 - i. Select and edit each variable.
3. **Define Search Rectangle (Define by axes)**
 - i. Define the rectangle's dimensions by using the **Major axis** and **Minor axis** boxes.
 - ii. Set the **Creep / Parallel direction** manually or set it as your Vessel's heading by using the ⁽²⁾ **Shortcut** button.
 - iii. Set the 1st turn direction by selecting **Port** or **Starboard**.

Variable	Maximum Value
Track spacing / Radius	5 nm / 5 sm / 5 Km
Search Speed	40 Kts / 46 Mph / 74 Kph
Major / Minor Axis	20 nm / 23 sm / 37 Km

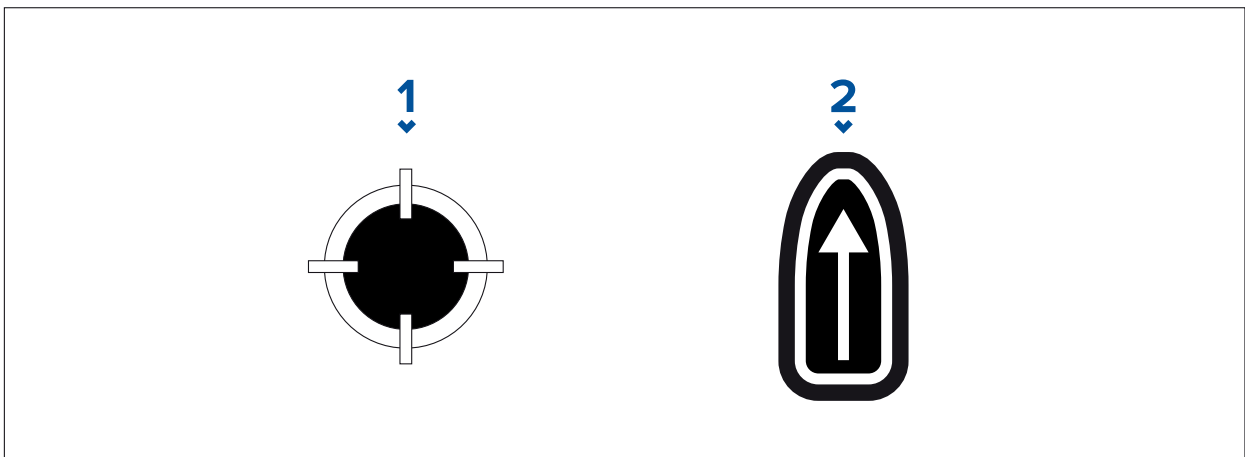

1. **CSP Shortcut**
2. **Creep / Parallel Direction Shortcut**
4. **Define Search Rectangle (Define by corner points)**

[If you would prefer not to define the search rectangle dimensions using the major and minor axis, the rectangle can be defined by setting the coordinates of each corner point instead]:

- i. Enter the coordinates of each corner point 1–4.

Note:

- The corner coordinates need to form a rectangle. If the coordinates are not suitable then you will not be able to create the search route.
- The CSP must be on one of the sides of the search pattern.
- For a Creeping Line search pattern the CSP must be located along one of the longer sides.
- For a Parallel Line search pattern the CSP must be located along one of the shorter sides.
- The CSP must be on a bearing of between 85° to 95° (i.e. right angle $\pm 5^\circ$) from the previous side.
- The CSP should be half a track width from the corner point.

8.13 Laylines

Laylines are used in sailing to show how far the vessel must sail on the current tack in order to make a target waypoint after tacking, given present wind conditions.

When a layline is used to calculate the route to a waypoint, it will take into account a number of factors to provide a better alternative course, compared to simply navigating in a straight line to a waypoint.

The reason why laylines are a more efficient way to sail to a specific point is because they're based on True Wind Direction (TWD) and either: a) fixed upwind / downwind sailing angles, or b) the use of polars to reflect the performance of your particular vessel. In this respect, sailing along laylines maximizes your Velocity Made Good (VMG) to windward. Another reason why laylines are more accurate is because they can also be configured to account for tidal current, as well as the leeway of your vessel.

To ensure the layline calculations are as accurate as possible, it's important to ensure that the following settings are correctly configured:

- **Boat details (specifically those relating to sailing):** **Homescreen > Settings > Boat details**
- **Laylines settings:** **Chart app > Menu > Settings > Laylines**

For more information on these settings, refer to: [p.85 – Boat details](#) and [p.186 – Laylines settings](#)

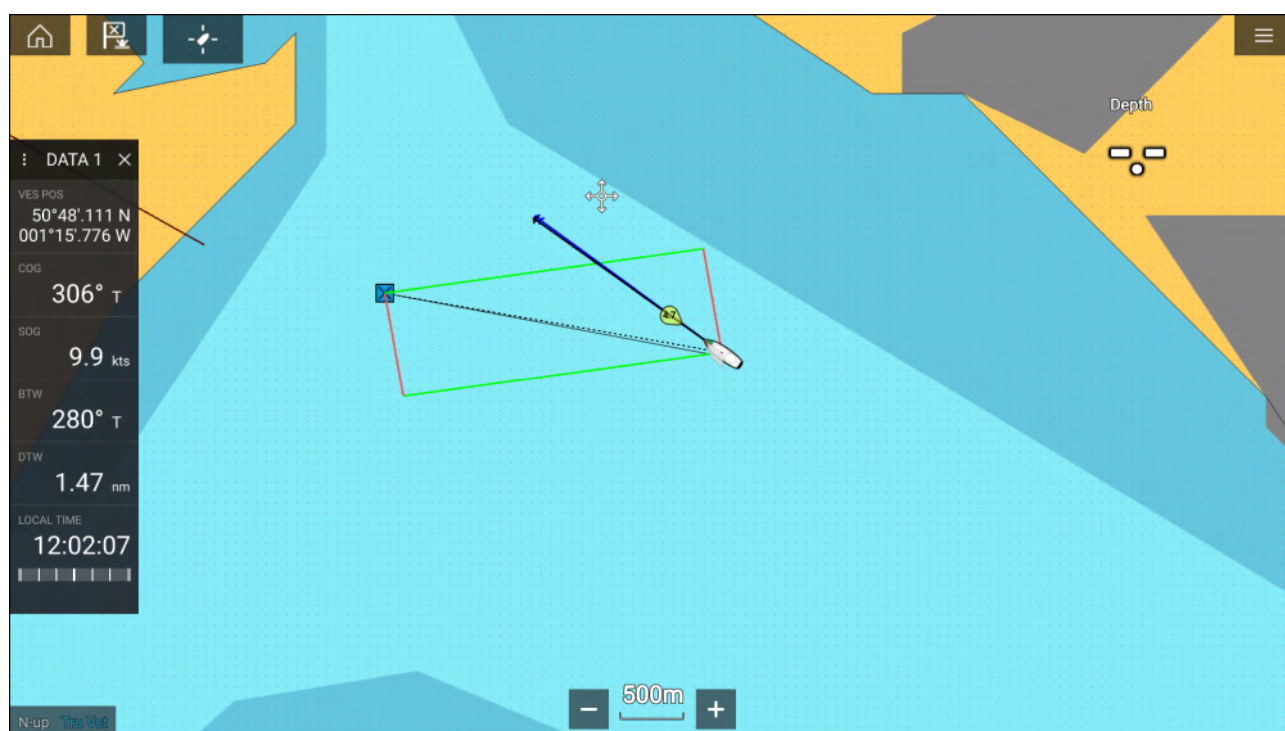

Note:

You should not steer your vessel so that its heading points exactly along the layline. Instead try to align your Course Over Ground (COG) with the visual laylines, as well as using the information displayed on the Sailing page in the **Dashboard app** to help you steer to your optimum wind angle. Your vessel should then travel along the layline, under the effects of tide and leeway.

Sailing data page

Sailing data and dials are available for display alongside laylines to help indicate which direction to turn in order to maximise your VMG to windward.

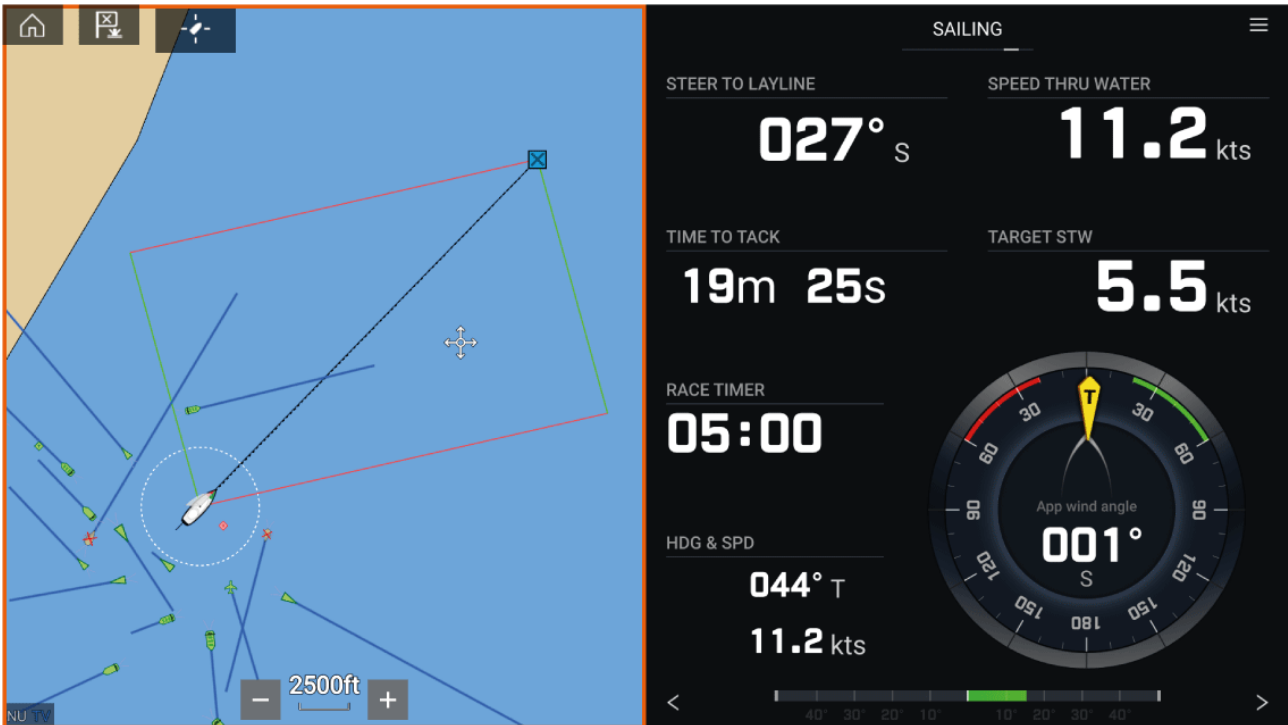

Sailing dials can be displayed in the **Dashboard app** by selecting the Sailing default data page. For more information on customizing the Sailing data page, refer to [Chapter 13 Dashboard app](#)

Laylines — system requirements

To use the Laylines feature, your system must meet the following conditions:

- Your MFD must be running LightHouse™ software version 3.9 or later.
- The **Boating Activity** setting must be set to **Sailing** during the MFD Startup Wizard procedure. For more information on how to configure the **Boating Activity** settings, refer to: [18.3 Getting started](#)
- The following data must be present on the MFD network:
 - Wind
 - Speed Through Water (STW)
 - GPS
 - Heading

Enabling Laylines

The Laylines feature can be enabled from the Laylines settings page in the **Chart app**.

Chart app > Menu > Settings > Laylines

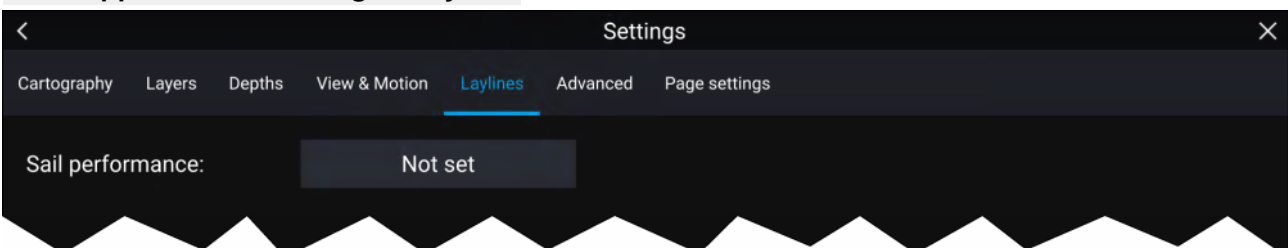

From this page you can select the Layline Sail Performance profile:

- Fixed, or
- Polar

With the relevant Sail Performance profile selected, laylines will be displayed automatically in the Chart app.

Laylines settings

The following settings are available on the laylines page:

Setting	Description	Options
Sail Performance	<p>Allows you to select a profile that determines the preferred level of sailing performance when using laylines. The laylines feature is only available when the profile is set to Fixed Angles or Polars.</p> <ul style="list-style-type: none"> • Not set — laylines are disabled. • Fixed Angles — laylines are created based on specified Upwind and Downwind angles. These angles are set by default to 45° and 140° respectively and can be configured in the menu. • Polars — laylines will be created using a polar table available on your MFD. You can select the relevant polar table using the Polar menu item, described below. 	<ul style="list-style-type: none"> • Not set • Fixed • Polar
(Fixed angle) Upwind angle	<ul style="list-style-type: none"> • Set the upwind angle for layline calculations. 	<ul style="list-style-type: none"> • 15° to 70° • 45° (default)
(Fixed angle) Downwind angle	<ul style="list-style-type: none"> • Set the downwind angle for layline calculations. 	<ul style="list-style-type: none"> • 125° to 175° • 140° (default)
(Polar) Polar	<ul style="list-style-type: none"> • Select the Polar table that will define your layline calculation. Selecting a vessel's make and model that most closely matches your own vessel will provide better calculations and more accurate laylines to follow when sailing. • If your vessel's make and model are not listed, submit the polar data for your vessel to: polars@raymarine.com so it can be included in the next software release. 	<ul style="list-style-type: none"> • List of available Polar tables
Display Layines on this chart	<ul style="list-style-type: none"> • Display or hide laylines on the current Chart app instance. 	<ul style="list-style-type: none"> • On • Off

Setting	Description	Options
Adjust for tides	<ul style="list-style-type: none"> Adjust the laylines to take into account tidal flow. 	<ul style="list-style-type: none"> On Off
Boat type	<ul style="list-style-type: none"> Set your vessel's boat type to provide more accurate leeway calculation. 	<ul style="list-style-type: none"> List of available Boat types
Show wind shifts	<ul style="list-style-type: none"> Display the minimum and maximum waypoint laylines, based on the varying True Wind Direction (TWD) over the last specified period. 	<ul style="list-style-type: none"> On Off
(Wind shifts) Time Period	<ul style="list-style-type: none"> Set the specified time period for wind shifts. 	<ul style="list-style-type: none"> 3 min 6 min (default) 12 min 30 min 60 min
(Wind shifts) Reset	<ul style="list-style-type: none"> Reset the recorded time of historical wind shifts back to 0. 	<ul style="list-style-type: none"> Reset

Displaying and interpreting laylines

Once laylines are enabled and correctly configured in the **Laylines** tab in the Chart app Settings, they will start rendering on the Chart display as your vessel is underway.

Laylines are displayed as a parallelogram under the following conditions:

- The vessel is under active navigation towards a **Waypoint** or **Goto**.
- A tack is required to meet an active **Waypoint** or **Goto**.
- The direct distance to the destination point is less than 150 nm from your vessel.

When the destination point is **upwind** the laylines will be displayed in a parallelogram formation, with green and red laylines showing the port and starboard tacks, as shown below:

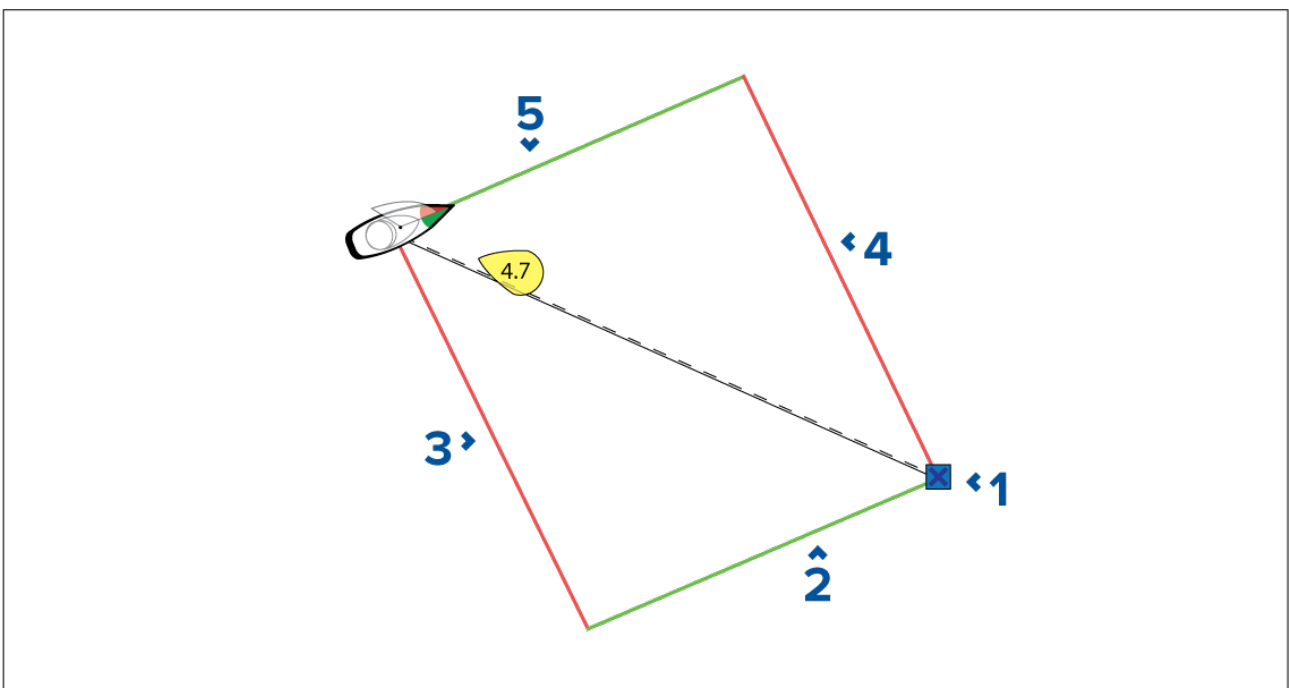

1. Destination
2. Starboard destination layline
3. Port vessel layline

4. Port destination layline
5. Starboard vessel layline

When the destination point is **downwind** the laylines will be displayed as an orange parallelogram formation, adjusted for gybing, as shown below:

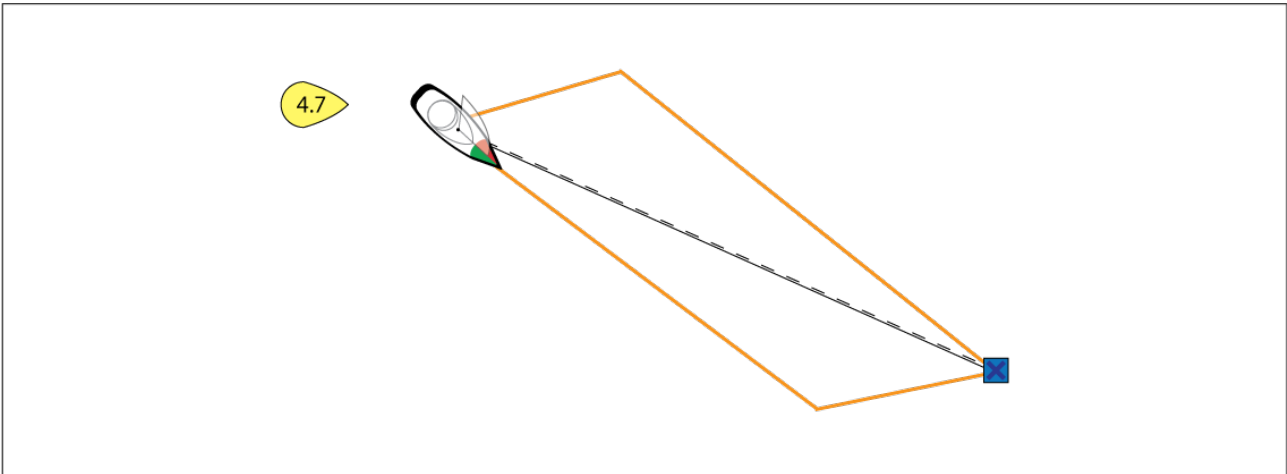

Displaying wind shift data

As True Wind Direction (TWD) is constantly changing, the position of the laylines changes over time. These changes are shown as lighter colored shaded triangles which represent the variation of TWD over a specified time period.

- With TWD holding at the high end of its range of variation, the vessel can tack to starboard and will lay the windward or leeward mark as it enters the shaded area. However, if TWD shifts back towards the lower end of its range of variation, the vessel will fall short of the layline and may have to perform extra tacks to reach the waypoint.
- With TWD holding at the low end of its range of variation, the vessel can tack to starboard and will only lay the windward or leeward mark when it reaches the end of the shaded area. However, if TWD shifts back towards the high end of its range of variation, the vessel will overstand the windward or leeward mark and may need to travel farther to reach the waypoint.
- Depending on the situation, the normal course of action would be to tack when the vessel is halfway through the shaded area. However this may not be the shortest or quickest route.

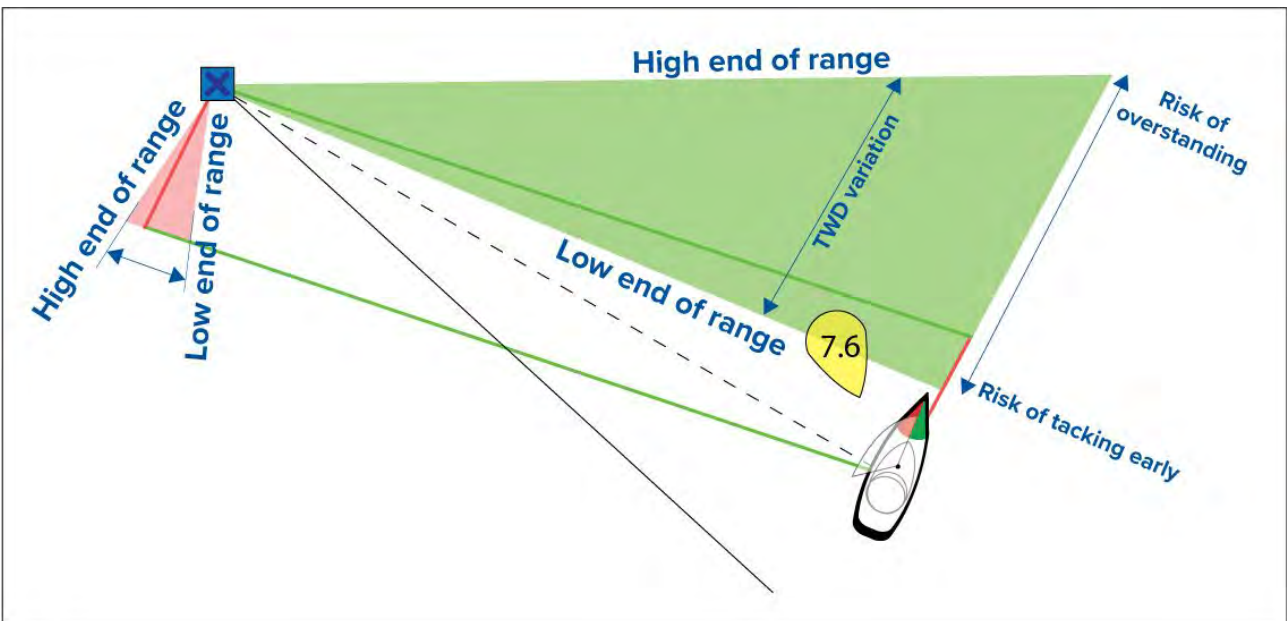

Wind shift data options are available from the **Laylines** settings page:

Chart app > Settings > Laylines



- **Show wind shifts** — Toggle wind shifts ON / OFF
- **Time Period** — Select the time period that you want the wind shift data to cover
- **Reset** — Reset the recorded wind shift data

8.14 Race Start Line (SmartStart) and Race Timer

The Race Start Line and Race Timer features can help you achieve a better racing start. The features assist you in approaching the race start line at the optimum speed, angle and time.

The basic concept of an effective race start is to guide your vessel and tune the sail configuration in an optimum way to ensure you are approaching the start line at the very last moment with full power. In race sailing, the countdown to this last moment is known as “Time to Burn”.

The race start line features help you to do this by providing a visual indication of the position of the race line on the Chart, as well as key data, including race timer, distance to start line, line bias, and Time to Burn. These features can also be used in conjunction with Laylines to further assist you in optimizing your approach to the start line. When the Race Start Line, Race Timer and Laylines are active, Laylines will visually protrude from the race start line’s port and starboard ends to help guide your vessel on an optimum course to the start line.

For more information on Laylines, refer to: [p.184 — Laylines](#)

The Race Start Line and Race Timer data is displayed in 2 different places:

- **In the Chart app’s Sidebar** — When the Chart app is in Racing mode, you can swipe from the left of the screen to display a sidebar showing the key race start information.
- **In the Dashboard app** — The dedicated Race Start page displays key race start information, including an apparent wind sailing dial, race timer, distance to start line, line bias, Time to Burn, and more. For more information, refer to: [p.301 — Race Start data items](#)

Note:

- Lighthouse software version 3.10 or later is required.
- The Race Start Line and Race Timer features require that the Chart app is set to Racing mode, accessible from the Chart app Menu.
- The Race Start Line and Race Timer sync to all MFDs on the network and can be interacted with on all MFDs on the network.
- Race Start Line and Race Timer options are available via the Sidebar when the Chart app is in Racing mode.



Creating the Race Start Line

A Race Start Line can be created by placing port and starboard end points.

The end points can be created by:

- Placing them anywhere on the Chart app — or for greater accuracy — placing them using existing chart waypoints and chart objects (e.g. Buoys).
- Pinging your vessel's current location, using GPS position data.

Once both end points have been entered, the race start line will be drawn between the two points.

Placing the Race Start Line

Race Start Line end points can be placed anywhere on the Chart app. You can use waypoints or chart objects to place Race Start Line end points at specific coordinates.

To place an end point on a waypoint or chart object:

1. Select the waypoint or chart object to display the context menu.
2. Select **Set start line**.
3. Select **Port end** or **Starboard end**.
4. Repeat for the alternate end.

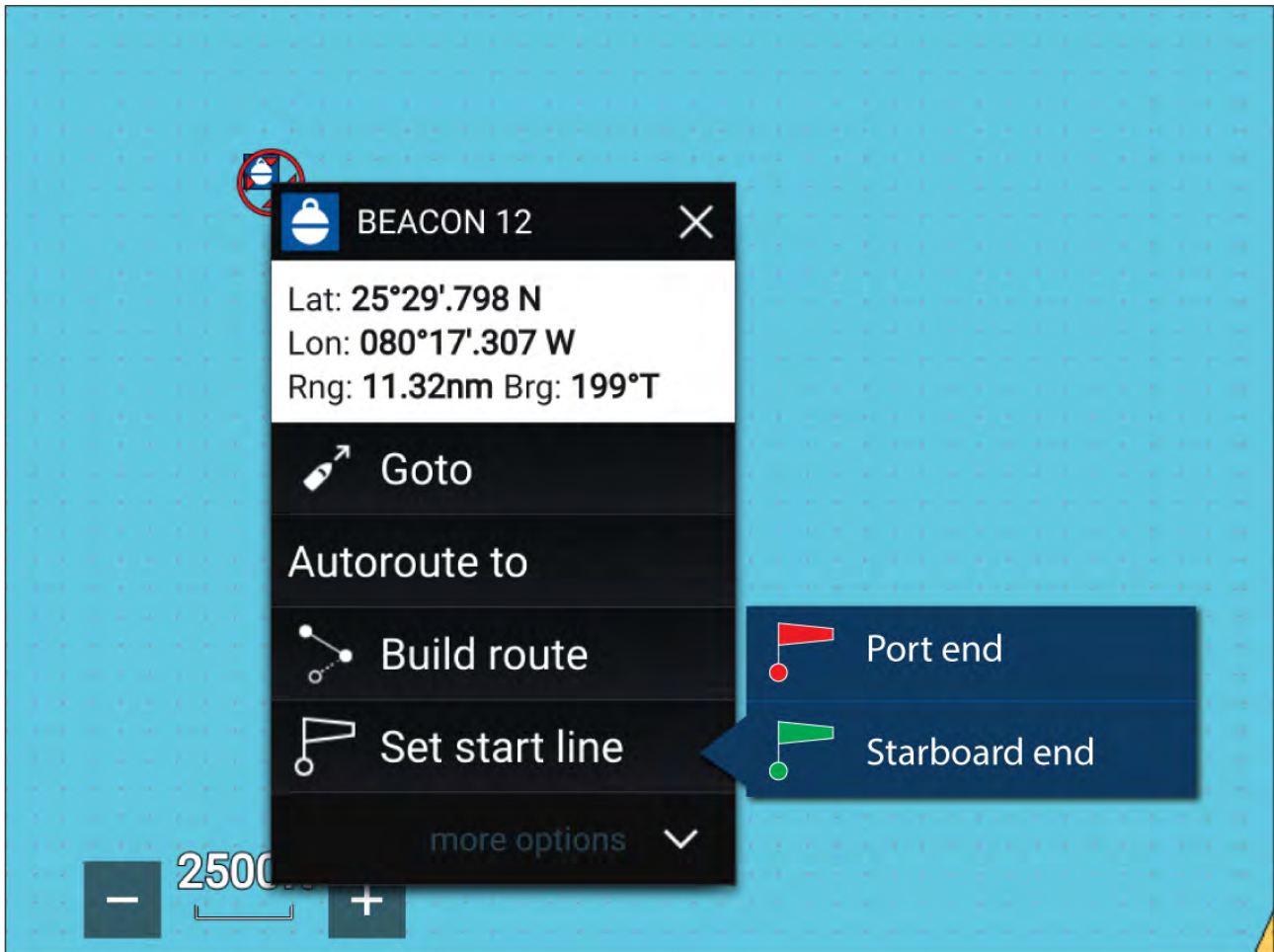

Pinging the Race Start Line

You can use your vessel's location to ping each end of the Race Start Line.

When your vessel is at the end point:

1. Open the menu.
2. Select **Race start line**.
3. Select either **Ping Port end** or **Ping Stbd (Starboard) end**.
4. Repeat for the alternate end.

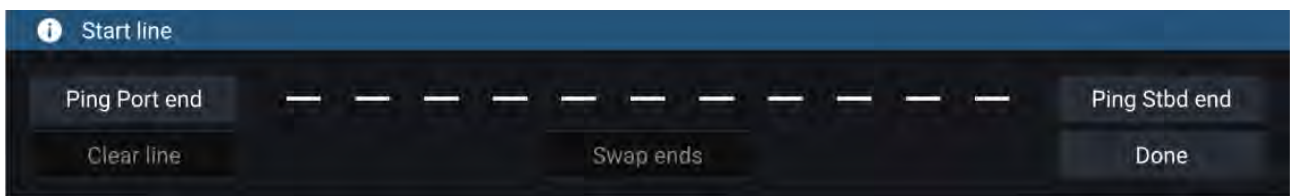

Important:

Pinging the Race Start Line ends will use your GPS location (from an internal or external GPS receiver). When pinging the end points, it is important to compensate for the distance between your vessel's bow and the GPS location.

To increase the accuracy of start line placement:

1. Approach an end point from the same direction you will be traveling when starting the race.
2. Align your vessel so it is perpendicular to the end point.
3. When the bow of your vessel reaches the end point, ping the location.
4. Repeat for the alternate end, ensuring your vessel remains perpendicular to the line.

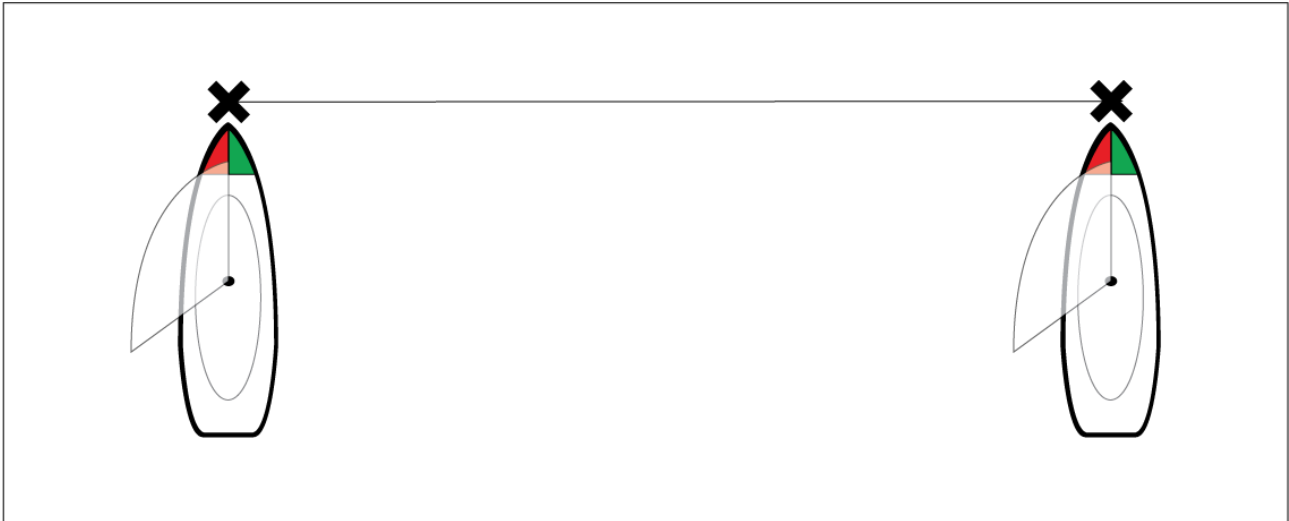

Editing and clearing the Race Start Line

The Race Start Line can be edited and deleted.

To edit the Race Start Line:

1. Select the line or end points on the chart app.
2. Select **Edit line**.

From here you can choose to swap the positions of the Port and Starboard end points, re-ping them to your vessel's current position, or clear the start line.

3. Select **Done** to save changes.

Starting the Race Timer

A Race Timer is available to count down until race start.

To start the Race Timer:

1. Open the menu.
2. Select **Race Timer**.
3. Select **Timer duration** to set the countdown time (default is 5 minutes).
4. Select **Start** to begin the countdown.

Important: The Race Timer can be set from 1 minute to 30 minutes.

5. You can change the countdown time as well as stop and reset the timer by reopening the Race Timer options menu.

Note:

The Race Timer can also be operated from the Dashboard app Race Start Page.

Race laylines

When the Race Start Line, Race Timer and Laylines are active, laylines will protrude from the race start line's port and starboard ends to help guide your vessel on an optimum course to the start line. A Favoured End Marker will also appear on the end point that provides a more competitive start. For more information on laylines refer to [8.13 Laylines](#)

The start line will appear differently depending on whether it is an upwind or downwind start:

- Upwind starts will show red and green laylines as well as a Favoured End Marker on the end point closer to the True Wind Direction (TWD).
- Downwind starts will show orange laylines as well as a Favoured End Marker on the end point farther from the True Wind Direction (TWD).

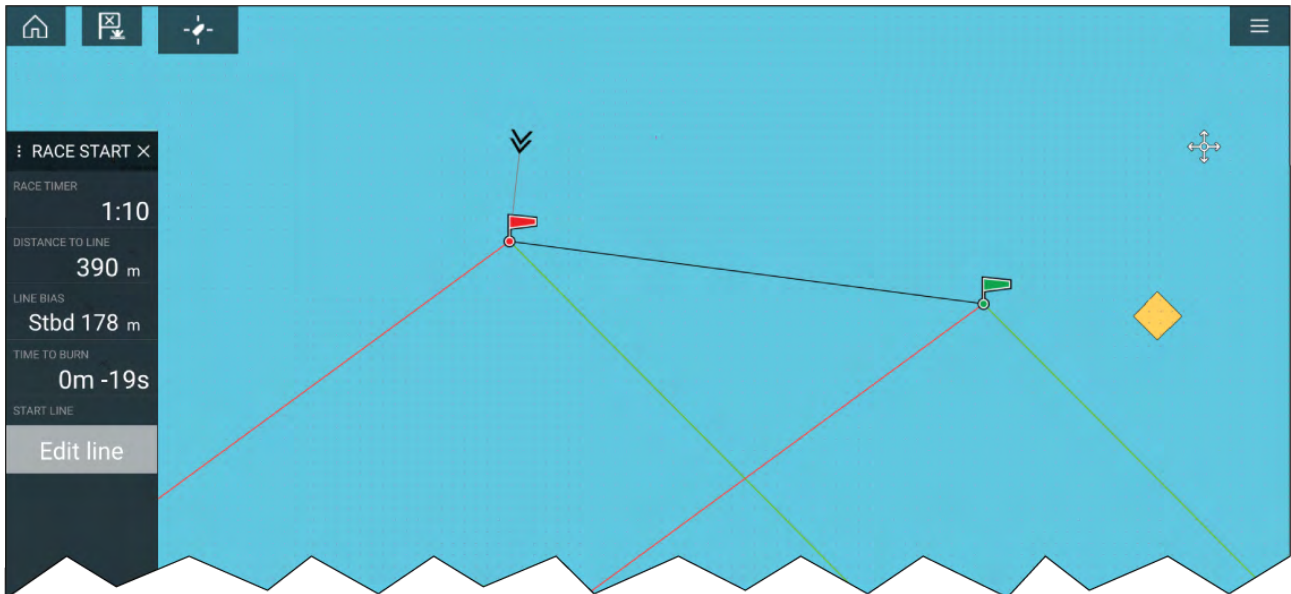

Race sidebar

Race Start Line and Race Timer information and options are available via the Sidebar when it is set to Race Start mode.

Menu item	Description	Options
Race Timer	Displays the countdown time until race start. When the timer reaches 0 it will begin to count up, indicating how long it has been since race start.	<p>Before Start</p> <ul style="list-style-type: none"> • Start • Timer duration <p>During Countdown</p> <ul style="list-style-type: none"> • Sync nearest minute • Up 1 minute • Down 1 minute • Stop & reset <p>When Counting Up</p> <ul style="list-style-type: none"> • Stop & reset
Distance To Line	Displays how far your vessel is from any point of the start line.	N/A
Line Bias	Displays how much closer or further away the favoured endpoint is to the wind in comparison to the other endpoint.	N/A
Time To Burn	Displays how much time you have before you need to navigate towards the start line. A negative value is shown if you are predicted to be running behind and will not be at the start line at race start. Time to burn is calculated using wind speed and speed through water (STW): <ul style="list-style-type: none"> • If you are using polars for sail performance then speed from the polar diagram is 	N/A

Menu item	Description	Options
	<p>used as the assumed starting speed through water.</p> <ul style="list-style-type: none"> If you are using fixed angles or have nothing set then you can manually set the expected speed or use your current speed by opening the race start line context menu (long pressing the start line). <p>For more information on sail performance refer to Laylines settings</p>	
Edit Line	<p>Allows you to edit the end points of the start line or clear it. You can ping the port or starboard end points to your current location as well as swap them.</p>	<ul style="list-style-type: none"> Ping Port end Ping Stbd (starboard) end Swap ends Clear Done

Dashboard

New race start data items are available in the dashboard app. These can be customized and displayed alongside the Race Start Line and Race Timer features. For more information refer to [Race Start data items](#)

8.15 ClearCruise™ Augmented Reality

The Chart app has additional Augmented Reality features, which are available when an AR200 and a compatible IP camera are connected.

Augmented Reality features must also be enabled and configured in the Video app.

With the Augmented Reality features enabled, the AIS Target, Waypoint and Chart Object data available in the Chart app will also be available in the video app, where the data will be overlaid onto the live video feed.

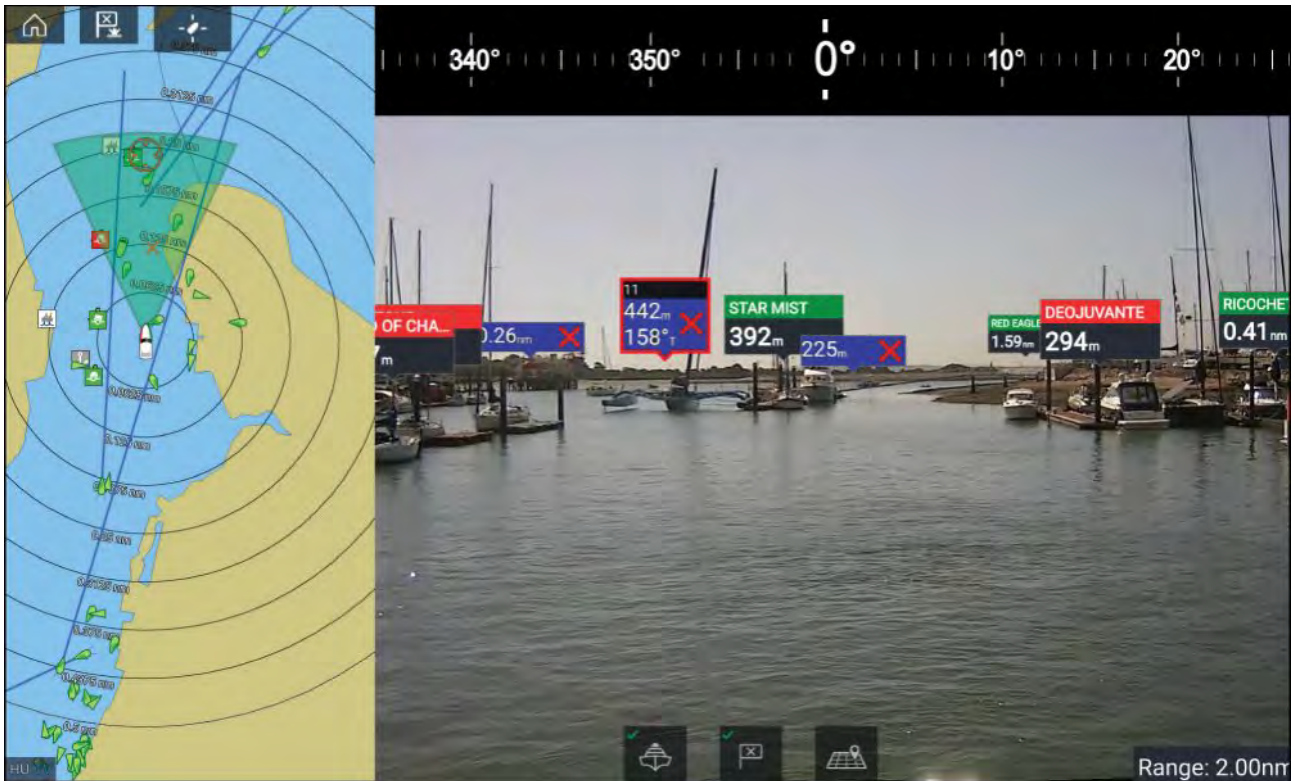

For further information on ClearCruise™ Augmented Reality, refer to [p.336 – ClearCruise™ features](#)

Field of View

The Field of View (FOV) cone acts as a range indicator to illustrate the area of coverage of the camera with respect to displaying chart objects in the Video app as part of the ClearCruise™ Augmented Reality features.

Chart objects that are within the scope of the displayed FOV cone will be displayed in the Video app as “flags”. For more information on flags, refer to [p.344 – Augmented Reality flags](#)

The area of coverage of the FOV cone is determined by:

- The camera’s horizontal Field of View (FOV). This setting can be adjusted in the Video app: **Video settings > Camera Setup tab**.
- The Augmented Reality Range Limit. For more information refer to [p.349 – Range limit](#). You can also manually specify the maximum range limit; refer to [p.348 – ClearCruise settings \(Augmented Reality\)](#) for more information. When you adjust this setting, the FOV cone in the Chart app will change accordingly.



The FOV cone can be enabled/disabled in the Chart app settings: **Menu > Settings > Layers**.

8.16 UAV Chart integration

When a compatible UAV with a GNSS (GPS) position fix is connected to your MFD, a UAV icon representing the position of the UAV is displayed in the Chart app.

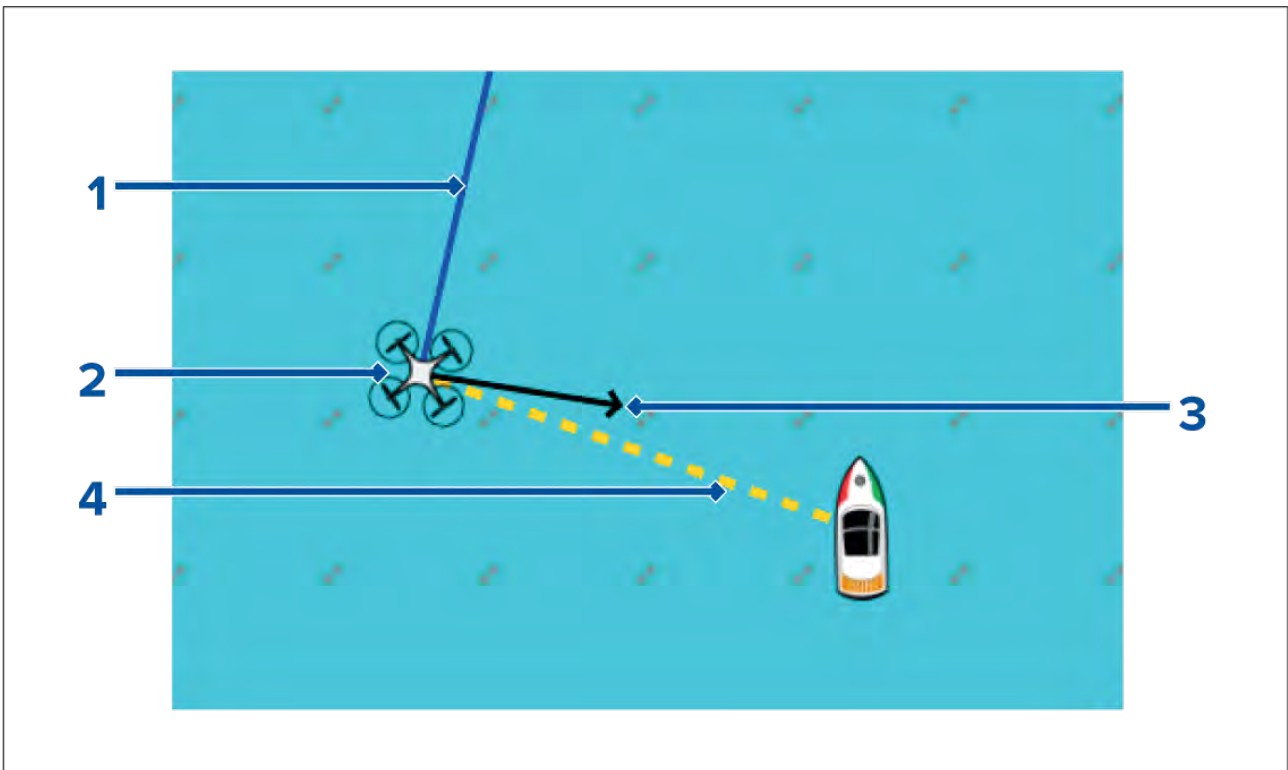

1	<p>UAV COG</p> <p>The direction of the Blue line indicates the UAV's current Course Over Ground (COG). The length of the line indicates the UAV's predicted position when the specified vector Reference period has passed.</p> <p>The Vector Reference period can be adjusted from the vessel icon's context menu.</p>
2	<p>UAV Icon</p> <p>Displayed when the UAV option is enabled in the Chart app settings, and your UAV has a GNSS (GPS) position fix.</p>
3	<p>Camera heading</p> <p>The Black Camera heading arrow is fixed to provide an indication of the direction the UAV's camera is pointing towards.</p>
4	<p>Line to vessel</p> <p>The Yellow dotted line represents the angle of the UAV's position relative to your vessel.</p>

Showing or hiding the UAV icon

The UAV icon is displayed by default in the Chart app. The icon can be hidden if required.

From the Chart app menu:

1. Select **Settings**.
2. Select the **Layers** tab.
3. Select the **UAV**: toggle switch.

Selecting the UAV toggle switch will make the UAV icon visible (on) or invisible (off).

Performing a UAV Goto

When your UAV is in flight you can select a location or object in the Chart app and perform a **UAV Goto** (your UAV will fly to the selected location or object and hover).

1. Select a location or object in the Chart app.
The Chart context menu is displayed.
2. Select **More**.
3. Select **UAV Goto**.

A UAV waypoint marker is placed to signify the UAV's destination and the UAV will fly to that location.

You can stop a UAV Goto at anytime by selecting the Red **Cancel UAV Goto** that is displayed onscreen in the UAV app, when a UAV Goto is active. Cancelling a UAV Goto will stop the Goto action and the UAV will hover in its current location.

A UAV Goto can be cancelled at any time by selecting **Stop UAV Goto** from the Chart context menu.

8.17 SonarChart™ Live

You can create personal bathymetry charts using your depth transducer and the SonarChart™ Live feature, available with compatible Navionics® electronic cartography cards.

Note: Before using SonarChart™ Live ensure you have correctly configured your transducer depth settings.

When using SonarChart™ Live, new contour lines are drawn in real time on the screen based on your transducer's depth readings. Color shading is used to reflect depth, with dark red signifying the shallowest area. The sonar data is recorded to your cartography card and is shared with Navionics when you update your chart card online.

Tide correction

SonarChart™ Live records the actual readings from your depth transducer under current tide / water level conditions. You can enable automatic adjustment of depth readings based on normalized low tide / low water level depth data taken from a nearby Tide station.

Enabling SonarChart Live

To enable creation of real time SonarChart™ Live bathymetry lines:

With your transducer depth settings correctly configured and compatible cartography selected:

1. Select the **Depth** tab from the Chart app settings menu: **Chart app > Menu > Settings > Depth**.
2. Enable **Sonar logging**.
3. Enable **SonarChart Live**.
4. Select the **Visibility** setting field, and adjust to your preferred value.
5. If required, enable **Tide correction**.

8.18 Chart settings menu

The table below lists settings applicable to the Chart app and their location within the app's **Settings** menu. Available settings are dependent on the cartography in use. If a setting is not displayed then the feature is not compatible with your cartography. If a feature is grayed out then it requires a subscription to activate the feature.

Cartography

Description	Options
<p>Allows you to select the cartography that you want to use in the current Chart app.</p> <hr/> <p>Note:</p> <ul style="list-style-type: none"> • Cartography options are available for charts on an inserted memory card or installed to the internal memory to your MFD. • When configured for S-63 Encrypted Charts S-63 related options will be available. 	<ul style="list-style-type: none"> • LightHouse Chart • S-63 Encrypted Charts • Navionics • C-MAP

Layers tab

Menu item and description	Options
<p>Chart detail: Allows you to select the level of detail displayed onscreen for vector based cartography. This setting is available when using LightHouse™, Legacy LightHouse™, C-MAP® and Navionics® charts.</p>	<ul style="list-style-type: none"> • Low • Medium • High
<p>Chart Object Size Adjust the display size of chart objects. This setting is available when using LightHouse™ charts and S-63 charts.</p>	Slider bar control.
<p>Day color palette When enabled Bright sun switches to a darker color palette in the Chart app which is more easily readable in bright sunlight. This setting is available when using LightHouse™ charts.</p>	<ul style="list-style-type: none"> • On • Off
<p>Chart style Switch between chart presentation styles. This setting is available when using LightHouse™ charts.</p>	<ul style="list-style-type: none"> • Leisure • Government
<p>AIS Enables and disables the display of AIS targets in the Chart app.</p> <hr/> <p>Note: AIS hardware is required.</p> <p>This setting is always available and not dependent on the charts in use.</p>	<ul style="list-style-type: none"> • On • Off

Menu item and description	Options
<p>Radar Enables and disables the display of a Radar overlay in the Chart app.</p> <hr/> <p>Note: Radar hardware is required.</p> <p>This setting is always available and not dependent on the cartography in use.</p>	<ul style="list-style-type: none"> • On • Off
<p>Aerial overlay Enables and disables display of a photographic aerial overlay. This setting is available when using C-MAP® and Navionics® charts.</p>	<ul style="list-style-type: none"> • On • Off
<p>Range rings Enables and disables the display of Radar style range rings in the Chart app. This setting is always available and not dependent on the cartography in use.</p>	<ul style="list-style-type: none"> • On • Off
<p>FOV: Enables and disables the ClearCruise™ Augmented Reality (AR) camera's field of view (FOV) overlay in the Chart app.</p> <hr/> <p>Note: ClearCruise enabled camera is required.</p> <p>This setting is always available and not dependent on the charts in use.</p>	<ul style="list-style-type: none"> • On • Off
<p>Weather Radar Enables Weather Radar precipitation data overlay in the Chart app.</p> <hr/> <p>Note: Only available when connected to a compatible SiriusXM weather receiver with a valid subscription.</p> <p>This setting is always available and not dependent on the charts in use.</p>	<ul style="list-style-type: none"> • On • Off
<p>Tides Enables and disables display of Tide and Current graphics at tide and current stations. This setting is available when using Navionics® charts.</p>	<ul style="list-style-type: none"> • On • Off
<p>Streets & POI Enables and disables the display of enhanced street details and point of interest in the Chart app. This setting is available when using LightHouse™ charts with a valid premium subscription.</p>	<ul style="list-style-type: none"> • On • Off
<p>UAV Displays the UAV icon, the UAV heading (camera direction), UAV COG and a line between the UAV and your vessel. This setting is always available and not dependent on the charts in use.</p>	<ul style="list-style-type: none"> • On • Off
<p>AIS PAD Enables the collision avoidance interception zone layer for AIS targets. Only available when the AIS layer is enabled.</p> <hr/> <p>Note: For more information about the collision avoidance feature refer to p.152 – Predicted areas of danger</p> <p>This setting is always available and not dependent on the charts in use.</p>	<ul style="list-style-type: none"> • On • Off

Menu item and description	Options
<p>Radar PAD Enables the collision avoidance interception zone layer for Radar targets. Only available when the Radar layer is enabled.</p> <p>Note: For more information about the collision avoidance feature refer to p.152 – Predicted areas of danger</p> <p>This setting is always available and not dependent on the charts in use.</p>	<ul style="list-style-type: none"> • On • Off
<p>EasyView Enables and disables the magnification of useful icons and text, making them easier to read. This setting is available when using Navionics® charts.</p>	<ul style="list-style-type: none"> • On • Off
<p>Community edits Enables and disables the display of crowd-sourced data. This setting is available when using Navionics® charts.</p>	<ul style="list-style-type: none"> • On • Off
<p>High res bathy Enables and disables the display of High Resolution Bathymetry charts, which provide improved bottom detail, contours and structure. This setting is available when using C-MAP® charts.</p>	<ul style="list-style-type: none"> • On • Off
<p>Sports fishing Allows you to display easy-to-use information pages about fishing locations including fish type, size, depth, and reef and bottom composition. This setting is available when using C-MAP® charts.</p>	<ul style="list-style-type: none"> • On • Off
<p>Marine protected areas Allows clear identification of areas where commercial and recreational fishing is prohibited or restricted. This setting is available when using C-MAP® charts.</p>	<ul style="list-style-type: none"> • On • Off
<p>Fishing AOI Enables and disables the display of Fishing AOIs (Areas Of Interest). This setting is available when using LightHouse™ and C-MAP® charts.</p>	<ul style="list-style-type: none"> • On • Off
<p>ActiveCaptain Enables and disables the display of crowd-sourced data. This setting is available when using C-MAP® charts.</p>	<ul style="list-style-type: none"> • On • Off

Depths tab

Menu item and description	Options
<p>Show soundings Enables and disables the display of depth soundings on the chart. When set to Manual, depth soundings will be shown from Zero to the maximum depth you specify. This setting is not available for Raster charts</p>	<ul style="list-style-type: none"> • None • Manual • All
<p>Show contours Enables and disables the display of depth contours on the chart. When set to Manual, contours will be shown from zero to the maximum depth you specify. This setting is available when using LightHouse™, C-MAP® and Navionics® vector charts.</p>	<ul style="list-style-type: none"> • None • Manual • All
<p>Shallow contour Determines the depth at which the Shallow contour is displayed. The Shallow contour cannot be set to a value greater than the Safe contour or Deep contour value. This setting is available when using LightHouse™, legacy LightHouse™ and S-63 vector charts.</p>	Numeric depth value

Menu item and description	Options
<p>Safe contour Determines the depth at which the Safe contour is displayed. The Safe contour cannot be set to a value that is less than the Shallow contour or greater than the Deep contour. This setting is available when using LightHouse™, legacy LightHouse™ and S-63 vectors charts.</p>	<p>Numeric depth value</p>
<p>Shallow area Enables and disables identification of areas deemed to be shallow. When enabled, a red hatched area is displayed in areas shallower than the depth specified in the Zero to field. This setting is available when using Navionics® charts.</p>	<ul style="list-style-type: none"> • On • Off
<p>Deep contour: Determines the depth at which the deep contour. This setting is not available for Raster charts</p>	<p>Numeric depth value</p>
<p>Depth gradient Allows you to specify the gradient shade between shallow and deep. This setting is available when using LightHouse™ and legacy LightHouse™ vector charts.</p>	<ul style="list-style-type: none"> • Dark to light • Light to dark
<p>Deep water color Allows you to specify the color that will be used to display Deep water. This setting is available when using C-MAP® and Navionics® charts.</p>	<ul style="list-style-type: none"> • White • Blue
<p>Record depth data Enables depth and position data to be recorded to memory card. This setting is available when using LightHouse™ and legacy LightHouse™ vector charts.</p>	<ul style="list-style-type: none"> • On • Off
<p>Waterline to tdc Enter the distance between the waterline and your depth transducer. This setting is available when using LightHouse™ and legacy LightHouse™ vector charts.</p>	<p>Numeric depth value</p>
<p>Save to When a suitable MicroSD card has been inserted the free space available for recording depth data and RealBathy is displayed. This setting is available when using LightHouse™ and legacy LightHouse™ vector charts.</p>	<ul style="list-style-type: none"> • SD1 • SD2
<p>RealBathy Displays previously recorded RealBathy™ data saved on memory card on the chart. This setting is available when using LightHouse™ and legacy LightHouse™ vector charts.</p>	<ul style="list-style-type: none"> • On • Off
<p>Visibility Determines the transparency of the RealBathy data displayed onscreen. This setting is available when using LightHouse™ and legacy LightHouse™ vector charts.</p>	<ul style="list-style-type: none"> • 0% to 100%
<p>Height correction Determines the level of height correction applied to RealBathy and depth data. This setting is available when using LightHouse™ and legacy LightHouse™ vector charts.</p>	<ul style="list-style-type: none"> • None • Tidal • Lake level
<p>Density Selects the density of available depth contours. This setting is available when using LightHouse™ and legacy LightHouse™ vector charts.</p>	<ul style="list-style-type: none"> • Low • Medium • High • Very high

Menu item and description	Options
<p>Sonar logging Allows logging of depth and position data to your Navionics chart card. This setting is available when using Navionics®charts.</p>	<ul style="list-style-type: none"> • On • Off
<p>SonarChart Live Enables and disables the Navionics SonarChart Live feature, which enables the realtime creation and display of high resolution bathymetry charts. This setting is available when using Navionics®charts.</p>	<ul style="list-style-type: none"> • On • Off
<p>Visibility Determines the level of transparency used when displaying SonarChart data. This setting is available when using Navionics®charts.</p>	<ul style="list-style-type: none"> • 0% to 100%
<p>Tide correction Enables Sonar logging depth measurements to be offset by tide height data from nearby tide stations. This setting is available when using Navionics®charts.</p>	<ul style="list-style-type: none"> • On • Off
<p>Shallow depth shading Enables and disables the identification of areas deemed to be shallow. When set to On, a red hatched area is displayed in areas shallower than the specified depth. This setting is available when using Navionics®charts.</p>	<ul style="list-style-type: none"> • On • Off
<p>Density Determines the density of available depth contours. This setting is available when using Navionics®charts.</p>	<ul style="list-style-type: none"> • Very high • High • Medium • Low
<p>Fishing Zone You can set up a Fishing Range by enabling Fishing Zone and specifying a minimum and maximum depth. Areas on the chart that are between these depths will be colored White; areas outside of these depths will be colored Blue. This setting is available when using Navionics®charts.</p>	<ul style="list-style-type: none"> • On • Off

View & Motion tab

The options available in the **View & Motion** tab are not dependent on charts in use.

Menu item and description	Options
<p>Chart motion Relative motion In Relative motion mode the vessel icon remains fixed onscreen and the chart area moves relative to your position. In this mode you can adjust your vessel's fixed position using the Boat position setting. True motion In True motion mode the chart is fixed and your vessel icon moves around the chart. As your vessel's position reaches the edge of the screen, the chart is redrawn to reveal the area in front of your vessel. Auto range In Auto range the largest possible scale is maintained that will display both your vessel and the destination / target waypoint simultaneously.</p>	<ul style="list-style-type: none"> • Relative motion • True motion • Auto range
<p>Chart orientation North-up In North-up the top of the screen always points towards north. As your vessel's heading changes, the vessel icon rotates accordingly. Head-up</p>	<ul style="list-style-type: none"> • North-up • Head-up • Course-up

Menu item and description	Options
<p>In Head-up the top of the screen always points towards your vessel's current heading, and as your heading changes the chart rotates accordingly.</p> <p>Course-up In Course-up the top of the screen always points towards your destination, and as your destination changes the chart rotates accordingly.</p>	
<p>Boat position The boat position determines the position of your vessel icon onscreen. The default is Center but you can adjust this to provide a greater distance in front of your vessel. Your boat position can only be changed when Chart motion is set to Relative motion.</p>	<ul style="list-style-type: none"> • Center • Partial offset • Full offset
<p>Sync view with other charts: All charts with Sync turned On will synchronize orientation and position.</p>	<ul style="list-style-type: none"> • On • Off

Laylines

The Laylines tab is available when a **Sailing** is selected as your boating activity during the MFD's initial start up wizard.

Menu item and description	Options
<p>Sail Performance Choose between Layline types:</p> <ul style="list-style-type: none"> • Not set — Laylines are disabled. • Fixed Angles — the vectors are created based on specified Upwind and Downwind angles. These angles are set by default to 45° and 165° respectively and can be configured in the menu. • Polars — the vectors use an imported polar table for your vessel to create the laylines. 	<ul style="list-style-type: none"> • Not set • Fixed • Polar
<p>Upwind angle When Fixed angle sail performance is selected you can set the angle of upwind layline calculations</p>	<ul style="list-style-type: none"> • 15° to 70° • 45° (default)
<p>Downwind angle When Fixed angle sail performance is selected you can set the angle of downwind layline calculations</p>	<ul style="list-style-type: none"> • 125° to 175° • 165° (default)
<p>Polar When Polar sail performance is selected you can select the Polar table that will affect your layline calculation. Selecting your vessel's make and model will provide better calculated laylines to follow when sailing.</p>	<ul style="list-style-type: none"> • List of available Polars
<p>Display Layines on this chart Display or hide laylines on the current Chart app instance</p>	<ul style="list-style-type: none"> • On • Off
<p>Adjust for tides Adjust the laylines to take into account tidal flow</p>	<ul style="list-style-type: none"> • On • Off
<p>Boat type Set your vessel's boat type to provide more accurate leeway calculation</p>	<ul style="list-style-type: none"> • List available Boat types

Note:

- The level of detail available on charts is dependent on vendor, chart type, subscription level and geographic region. Prior to purchasing charts check the vendor's website to establish what level of detail is available on the charts you want to purchase.
- The information relating to available chart detail and settings in this manual should be treated as guidance only as it is subject to change that is not under Raymarine's control.

Advanced tab

Menu item and description	Options
<p>Chart orientation</p> <p>North-up In North-up the top of the screen always points towards north. As your vessel's heading changes, the vessel icon rotates accordingly.</p> <p>Head-up In Head-up the top of the screen always points towards your vessel's current heading, and as your heading changes the chart rotates accordingly.</p> <p>Course-up In Course-up the top of the screen always points towards your destination, and as your destination changes the chart rotates accordingly.</p>	<ul style="list-style-type: none"> • North-up • Head-up • Course-up
<p>Enhanced AIS targets Switches between using standard and enhanced AIS targets.</p>	<ul style="list-style-type: none"> • On • Off
<p>Auto find ship When enabled the Chart app will automatically center to your vessel after 30 seconds.</p>	<ul style="list-style-type: none"> • On • Off
<p>Use Radar without heading data Enables use of Radar overlay without Heading data.</p>	<ul style="list-style-type: none"> • On • Off
<p>Cursor info boxes Allows display of information pop-ups for targets and objects.</p>	<ul style="list-style-type: none"> • On • Off
<p>Tide animation interval Allows you to select the time interval used for the Tide and Current animations in Tides mode.</p>	<ul style="list-style-type: none"> • 15 minutes to 2 hours in 15 minute steps.
<p>Cartographic objects Enables and disables the display of cartographic objects. The settings available are dependent on the cartography in use.</p> <div style="background-color: #f0f0f0; padding: 5px; border: 1px solid black;"> <p>Note:</p> <ul style="list-style-type: none"> • (1) Available on Navionics®, C-MAP® and Legacy LightHouse™ charts. • (2) Available on all charts. • (3) Available on Navionics®, C-MAP®, Legacy LightHouse™ and LightHouse™ charts. • (4) Available on Navionics®, C-MAP®, Legacy LightHouse™, LightHouse™ and S-63 charts. • (5) Available on Navionics® and C-MAP® charts. • (6) This setting is always available and not dependent on the cartography in use. • (7) Available on Navionics® charts. • (8) Available on S-63 Encrypted Charts </div>	<ul style="list-style-type: none"> • Navigation marks (1) • Navigation mark symbols (1) • Rocks (2) • Light sectors (1) • Routing systems (3) • Caution areas (1) • Marine features (3) • Land features (4) • Business services (5) • Panoramic photos (5) • Roads (6) • Colored seabed areas (7) • Buoy names (8) • Light desc (8)

Menu item and description	Options
<p>Chart appearance Allows you to change the appearance of the Chart app. The settings available are dependent on the cartography in use.</p> <p>Note:</p> <ul style="list-style-type: none"> • (1) Available on Navionics® charts • (2) Available on Navionics® and LightHouse™ charts. • (3) Available on Navionics®, C-MAP® and LightHouse™ charts. • (4) This setting is always available and not dependent on the cartography in use. • (5) Available on Navionics®, C-MAP®, Legacy LightHouse™ and LightHouse™ charts. • (6) Available on C-MAP® and LightHouse™ charts. • (7) Available on Navionics® and C-MAP® charts. 	<ul style="list-style-type: none"> • 2D shading (1) • Aerial overlay (2) • Aerial overlay opacity (3) • Relief shading (1) • Grid (4) • Chart text (4) • Chart boundaries (5) • Text/symbol size (6) • Deep water color (7) • Community edits (1)
<p>My data appearance You can change how your User data appears in the Chart app. This setting is always available and not dependent on the cartography in use.</p>	<ul style="list-style-type: none"> • Waypoints names • Route names • Track names • Route width • Track width • Vector width • Vector length

Weather settings tab

Menu item and description	Description
<p>Wind symbol Determines whether Arrows or Barbs are used for Wind direction graphics in Weather mode.</p>	<ul style="list-style-type: none"> • Arrows • Barbs
<p>Marine zone boundaries Determines whether marine boundaries are shown in Weather mode.</p>	<ul style="list-style-type: none"> • On • Off
<p>Watchbox alerts Enables and disables Watchbox alerts.</p>	<ul style="list-style-type: none"> • On • Off
<p>Watchbox range Determines the range from your vessel that Watchbox alerts are displayed</p>	<ul style="list-style-type: none"> • 50nm • 150nm • 300nm • 500nm
<p>Signal strength Displays the signal strength of a connected weather receiver.</p>	Signal strength graph
<p>Receiver ESN Displays the Electronic Serial Number (ESN) of a connected weather receiver.</p>	ESN

Note:

The Weather settings tab is only displayed when the Chart app is set to Weather mode.

Page settings tab

- **Data Overlays** — Enables configuration of Data overlays, which overlay key information from connected sensors onto the Chart, Radar, Sonar and Camera apps.

- **Edit split ratio** — Enables you to customize the position of the partitions in splitscreen app pages. For example, 50/50, 70/30 etc.

Chapter 9: First responder

Chapter contents

- 9.1 First responder configuration on page 208
- 9.2 Data logging on page 210
- 9.3 Intel targets on page 211
- 9.4 DSC targets on page 213
- 9.5 Target Of Interest (TOI) on page 214
- 9.6 First responder AIS modes on page 219
- 9.7 SITREP (Situation report) on page 220
- 9.8 SAR pattern receipt on page 222
- 9.9 Messaging on page 222

9.1 First responder configuration

Configuring the MFD for First responders enables extra features that are otherwise not available on the MFD. Several of the First responder features require a STEDs compatible AIS transceiver to provide Sensitive Tactical Information Exchange and Display System (STEDS) functionality.

First responder and STEDS features require **First responder** to be selected as the 'Boating activity' during step 2 of the MFD's initial startup wizard.

Note:

To change boating activity a factory reset must be performed to initiate the startup wizard.

STEDS specific features also require:

- an AIS5000 to be connected to the same NMEA 2000 / SeaTalkng® network as the MFD.

Note: The AIS5000 must be correctly configured with an MMSI number and where required a radio operators license must be obtained.

- each vessel must be configured with the same STEDS passphrase.

STEDS features use the existing Automatic Identification System (AIS) network to transmit and receive messages and data but as the messages and data are encrypted they are not visible or available to standard Class A and Class B AIS receivers/ transceivers.

Note:

On an MFD network only the Data master MFD needs to be configured.

First responder features:

The following features are available when the MFD is configured as 'First responder':

- The **Responder** settings menu tab is available and the **Responder vessel type** can be selected. For details refer to: [p.208 – Responder setup](#)
- Data logging is enabled. For details refer to: [p.210 – Data logging](#)
- DSC target tracking are enabled. For details refer to: [p.213 – DSC targets](#)
- Intel target tracking is available. For details refer to: [p.211 – Intel targets](#)
- LightHouse™ charts obstruction alarm is available For details refer to: [p.161 – Obstruction alarm \(LightHouse charts\)](#)

First responder STEDS features:

The following STEDS features are available when the MFD is configured as 'First responder' and the STEDS requirements have been met:

- The STEDS text messaging app is available: For details refer to: [p.222 – Messaging](#)
- SITREP status can be configured. For details refer to: [p.220 – SITREP \(Situation report\)](#)
- AIS restricted mode is available. For details refer to: [p.219 – First responder AIS modes](#)
- Targets of Interest (TOI) feature is enabled. For details refer to: [p.214 – Target Of Interest \(TOI\)](#)
- Search and Rescue (SAR) patterns can be received over STEDS messaging. For details refer to: [p.222 – SAR pattern receipt](#)
- Blue Force tracking is used to identify other STEDS configured vessels. For details refer to: [p.220 – Blue Force Tracking](#)

Responder setup

The Responder menu tab is only available when **First responder** is selected as the 'Boating activity' during step 2 of the MFD's initial startup wizard. The Responder menu includes settings for STEDS specific features, which require an AIS5000 to be connected to the system.

- **Responder vessel type** — Select your responder vessel type from a list.
- **Boat name** — Enter your vessel name (this option is also available in the Boat details menu).
- **MMSI** — Set your vessel's MMSI number.

Important:

- In the United States of America (USA), the MMSI and Static Data must be entered only by a Raymarine® dealer or other appropriately qualified installer of marine communications equipment for marine vessels. In the USA, the user is NOT authorized to do this.
- In Europe and other parts of the world outside of the United States of America, the MMSI can be set up by the user.
- For further details, refer to the relevant Telecommunications Regulatory Body for your region.
 - In the United States of America (USA), the MMSI and Static Data must be entered only by a Raymarine® dealer or other appropriately qualified installer of marine communications equipment for marine vessels. In the USA, the user is NOT authorized to do this.
 - In Europe and other parts of the world outside of the United States of America, the MMSI can be set up by the user.
 - For further details, refer to the relevant Telecommunications Regulatory Body for your region.
- **AIS mode** — Determines the transmit/receive mode of STEDS AIS hardware. For details see: [p.219 — First responder AIS modes](#)
- **Passphrase** — Enter the designated passphrase your team / organization is using to transmit and receive STEDS messages.
- **Clear passphrase** — Deletes the entered passphrase.
- **Passphrase auto-wipe** — Passphrase expiry. Set the number of days before the passphrase is automatically deleted (the passphrase will be wiped at 00:00 UTC).
- **Data logging** — Enables and disables Data logging.
- **Logging interval** — Time interval between recording data.
- **Save to:** — Select the card slot to use for Data logging.
- **Advanced set-up** — Configure OneShot TOI settings and STEDS messaging transmission FIDs and checksums.
 - For details on OneShot TOI settings see: [p.216 — TOI OneShot settings](#)
 - For details on FIDs and checksums see: [STEDS messaging transmission FIDs and checksums](#)

STEDS messaging transmission FIDs and checksums

The SITREP and Static data functional IDs (FIDs) and FID checksum validation can be enabled and disabled from the **Advanced set-up** menu. **Homescreen > Settings > Responder > Advanced set-up > Configure**

STEDS messages

The following transmission SITREP and Static data FIDs are available:

- Tx FID 10 (SITREP)
- Tx FID 11 (Static data)
- Tx FID 56 (Legacy SITREP)
- Tx FID 57 (Legacy static data)

Note:

FID 10 and FID 11 are enabled by default. FID 56 and FID 57 are disabled by default.

Checksum validation

Checksum validation is enabled by default but can be enabled and disabled from the **Transmission checksums** menu: **Homescreen > Settings > Responder > Advanced set-up > Configure > Transmission checksums**.

When enabled received FID's checksums are checked to validate messages.

Checksum validation is available for the following FIDs:

- FID 3— PI message acknowledgement
- FID 4 — Target of interest — 15s
- FID 5 — Target of interest — 60s

- FID 6 — Target of interest — 180s
- FID 7 — Target of interest — 600s
- FID 8 — Target of interest — single
- FID 10 — Situation report (v0 and v1 supported when clear)
- FID 11 — Static data report (v0 and v1 supported when clear)
- FID 23 — Search pattern report (encrypted)
- FID 28 — Text message

9.2 Data logging

The Data Logger records, at regular intervals, readings taken by your vessel's equipment, an active Man overboard alarm, and the 5 closest AIS targets.

The Data logger is enabled by default and records data to a CSV file saved to a MicroSD card inserted into a card slot on the MFD. A new CSV file is created every hour up to a maximum of 73 files (72 hours of data), after which the first file will be overwritten by the next new Data logging file.

If the MicroSD card is removed or reaches capacity, Data logging will be suspended and a notification will be displayed onscreen.

Note:

- On MFD networks the Data master MFD performs the data logging.
- For optimal performance, Do NOT use cartography cards for Data logging.

The status of the Data logger is displayed in the status area of the Homescreen using icons.

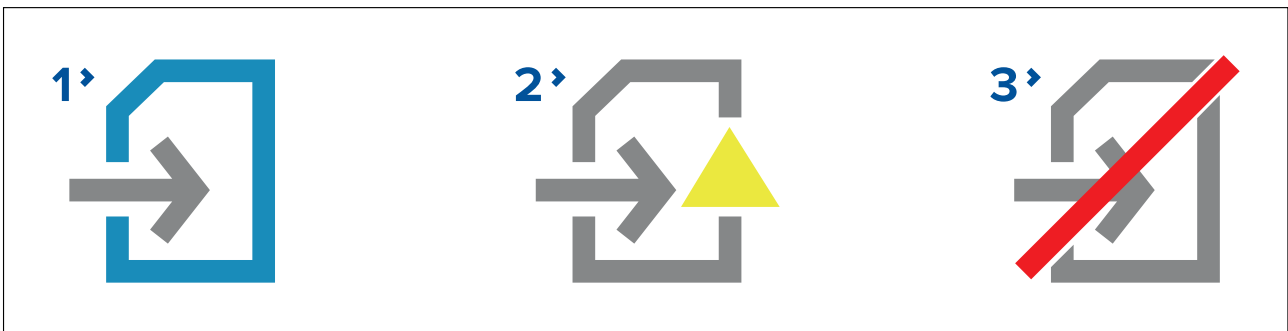

1. Data logging active
2. Data logging error (e.g.: no MicroSD card inserted)
3. Data logging disabled

The Data logger records the following data, when available:

Own vessel:

- Date and time
- Latitude and Longitude
- Heading
- Speed (SOG)
- Depth

Man Overboard:

- Latitude and Longitude
- Elapsed time

5 closest AIS targets:

- Vessel name
- Vessel MMSI
- Latitude and Longitude
- Heading

- Speed (SOG)

The Data logger can be configured from the **Responder** settings menu: **Homescreen > Settings > Responder**.

9.3 Intel targets

Intel targets are targets created manually based on visual or reported information of a vessel's position and if available, course and speed.

Intel targets are listed in the Intel targets list and an icon is used in the Chart app to represent the target.

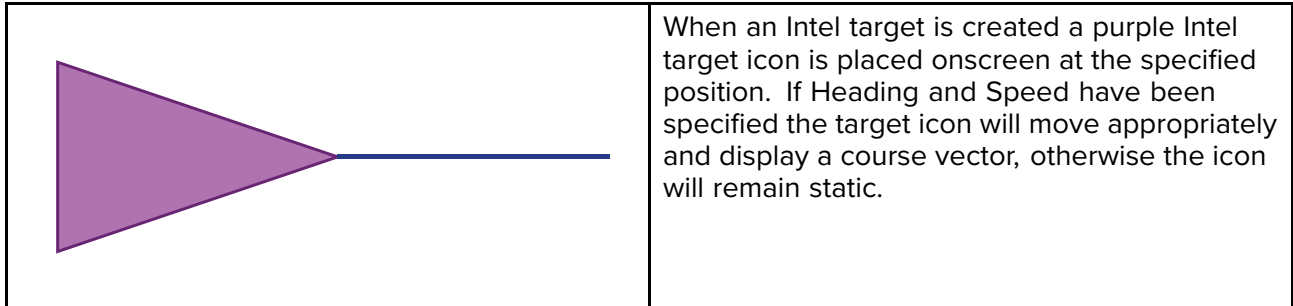

Intel targets will remain on the system until cancelled.

Creating an Intel target

Targets can be created using reported or sighted information about a target's location, Heading and Speed.

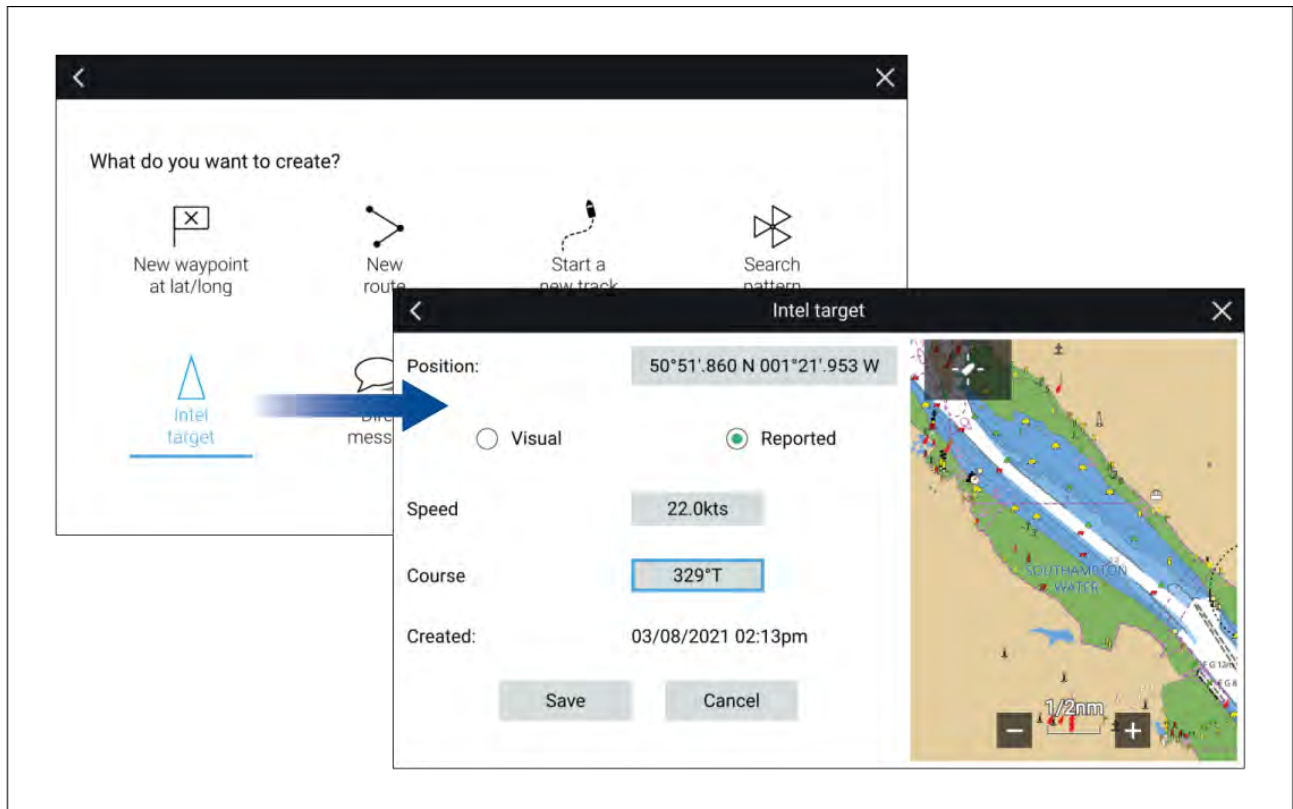

Intel targets are created from the Chart app's **New** menu: **Menu > New > Intel target**

To create an Intel target follow the steps below:

1. Place the cursor at the desired location in the Chart app..
2. Select **New** from the Chart app menu.
3. Select **Intel target**.
4. Ensure that the latitude and longitude for the target are correct in the **Position** field, adjusting if necessary.
5. Select whether the Intel is **Visual** or **Reported**.

6. Enter a **Speed** and **Course** for the Intel target.
7. Select **Save**.

The Intel target will be displayed in the Chart app using a purple target icon.

Intel targets can also be created from the Pop-over options in the Intel targets list: **Menu > Targets > Intel > New intel target**.

Accessing target options

Target specific options are available for targets that are currently being tracked. The target options can be accessed from the target's context menu and from the Pop-over options in the relevant target list. The options available are dependent on the type of target.

To access a target's context menu:

- Press and hold on the target onscreen, or
- Highlight the target onscreen using the **Direction controls** and press the **OK** button.

To access the target list Pop-over menu:

- Select the target in the relevant target list, or
- Highlight the target in the list using the **Direction controls** and press the **OK** button.

Intel target options

The following options are available for Intel targets.

- **Designate TOI** — If your MFD is configured for STEDS you can designate a target as a Target of Interest (TOI). For details see: [p.214 — Target Of Interest \(TOI\)](#)
- **Cancel Target** — Cancels the Intel target and removes it from the system.
- **Intercept** — Initiates a Target interception . For details see: [p.163 — Target intercept](#)
- **Show on chart** — Displays the target centered in the Chart app.

Intel target list

The target list identifies the target position, course, speed and the type of intel the target is based on (i.e.: Visual or Reported.). If the target has been designated as a TOI then the related Link ID will also be displayed.

The Intel targets list can be accessed from the Targets menu in the Radar app and Chart app: **Menu > Targets > Intel**.

Selecting a target from the list highlights the selected target in the LiveView app pane on the right of the page and opens the Pop-over menu.

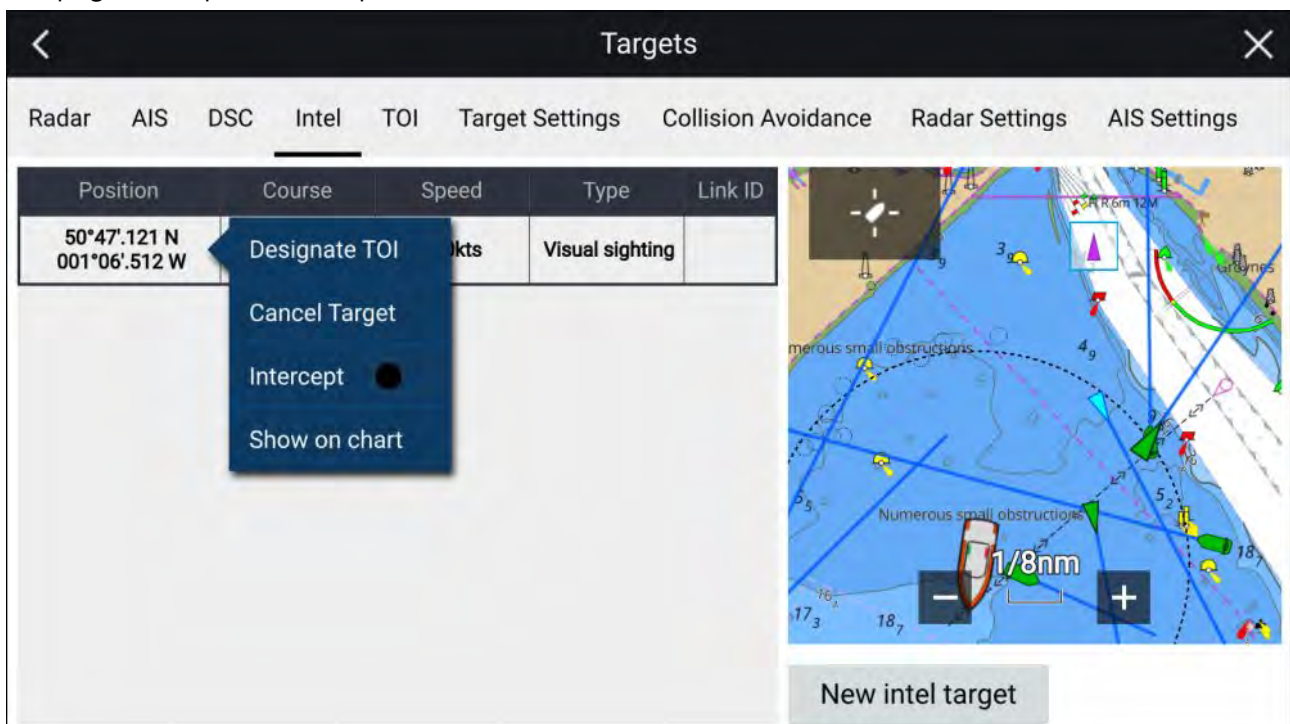

9.4 DSC targets

Waypoints created from DSC notifications will be displayed in the DSC target list and are displayed onscreen at the originating vessel's reported position.

For details on creating a waypoint from a DSC notification see: [p.82 — DSC VHF radio integration](#)

DSC target symbols are static and remain in the reported position, however if a DSC position update is received a new DSC waypoint symbol can be placed at the new location.

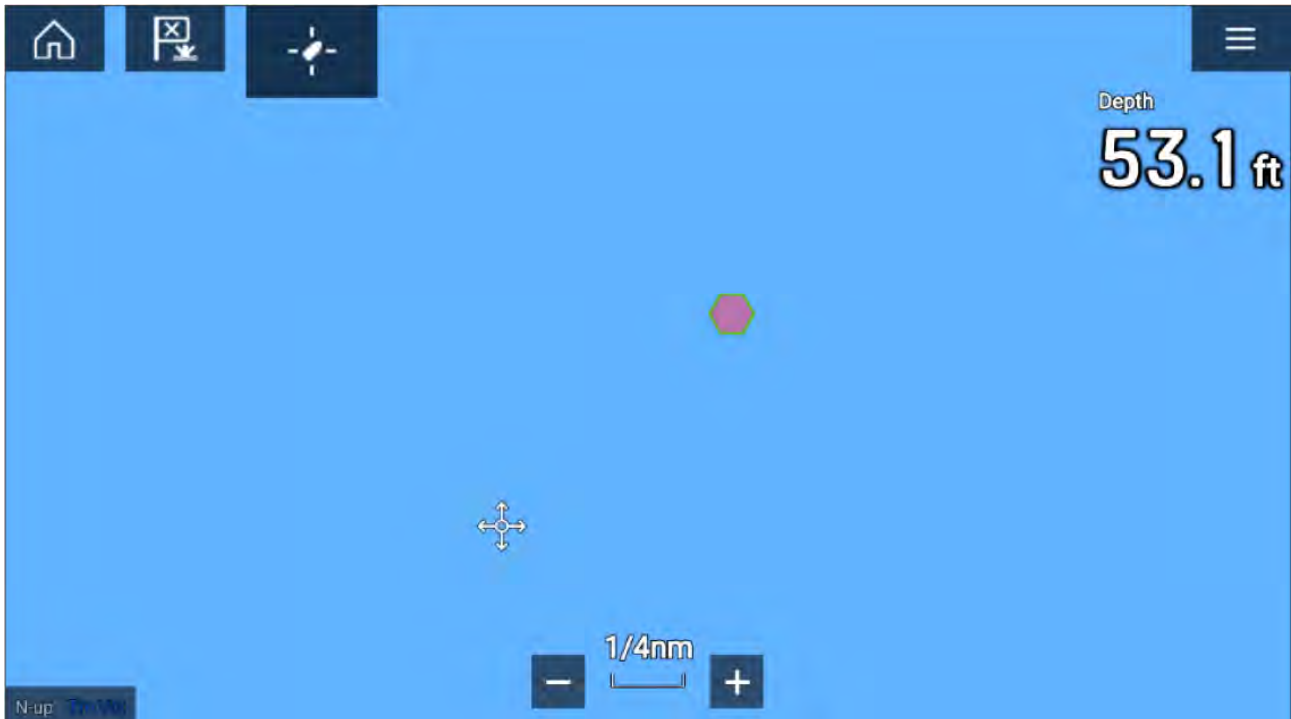

DSC targets will remain on the system until cancelled manually.

Accessing target options

Target specific options are available for targets that are currently being tracked. The target options can be accessed from the target's context menu and from the Pop-over options in the relevant target list. The options available are dependent on the type of target.

To access a target's context menu:

- Press and hold on the target onscreen, or
- Highlight the target onscreen using the **Direction controls** and press the **OK** button.

To access the target list Pop-over menu:

- Select the target in the relevant target list, or
- Highlight the target in the list using the **Direction controls** and press the **OK** button.

DSC target options

The following options are available for DSC targets.

- **Designate TOI** — If your MFD is configured for STEDS you can designate a target as a Target of Interest (TOI). For details see: [p.214 — Target Of Interest \(TOI\)](#)
- **Cancel Target** — Cancels the DSC target and removes the DSC waypoint from the system.
- **Intercept** — Initiates a Target interception . For details see: [p.163 — Target intercept](#)
- **Goto** — Initiate navigation to the target position.
- **Show on chart** — Displays the target centered in the Chart app.

DSC target list

The target list identifies: The MMSI number of the originating vessel, its reported Position, Range and Bearing from your vessel and the Type of distress. If the target has been designated as a TOI then the related Link ID will also be displayed.

The DSC target list can be accessed from the Targets menu in the Radar app and Chart app: **Menu > Targets > DSC**

Selecting a target from the list highlights the selected target in the LiveView app pane on the right of the page and opens the Pop-over menu.

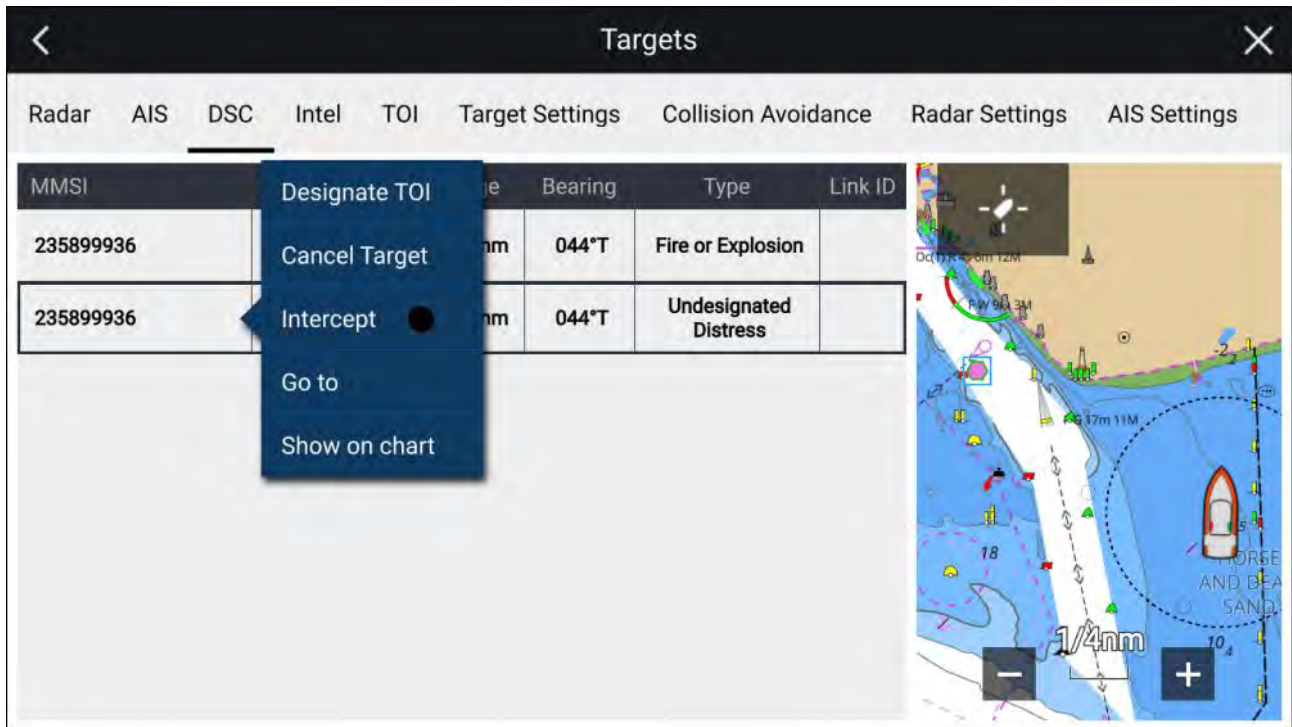

9.5 Target Of Interest (TOI)

AIS, Radar, DSC and Intel targets can be designated as TOIs. Once a target is designated as a TOI, STEDS messaging is used to broadcast the TOI to all vessels in range or to send the TOI to an individual MMSI number. TOIs can also be received over STEDS messaging.



Important:

Recipient MFDs must have the same STEDS passphrase installed as the sender's MFD.

TOIs can be assigned as 'OneShot' TOIs or as recurring TOIs. OneShot TOIs are sent once and are automatically cancelled after a specified decay period. Recurring TOIs are repeated until cancelled at the selected transmission rate.

TOIs created from Inter targets or DSC targets are always assigned as OneShot TOIs.

TOI icons are displayed in the Chart app and Radar app. Different icons are used to differentiate between sent and received TOIs.

	<p>Sent recurring TOI icon A recurring TOI is represented on the sender's MFD using a red triangle icon with 2 red rings around it. Recurring TOIs will be tracked until cancelled.</p>
	<p>Sent OneShot TOI icon A OneShot TOI is represented on the sender's MFD using a red triangle icon with 2 red dashed rings around it. OneShot TOIs will be tracked until the decay period has elapsed. See: p.215 – OneShot TOI decay times</p>
	<p>Received TOI icon A TOI that has been received from another vessel is represented on the recipient's MFD using a red triangle icon. When a TOI message is received a notification is displayed onscreen. The incoming message is saved in the Messages app. A TOI received from another vessel cannot be forwarded on to other vessels. Received TOIs will be tracked until cancelled.</p>

If a Radar target or AIS target that a TOI is based on becomes lost then the TOI will also become lost.

OneShot TOI decay times

TOIs designated as OneShot are temporary and are subject to a delay period before reverting to their original target states (i.e.: AIS target, Radar target, DSC target or Intel target).

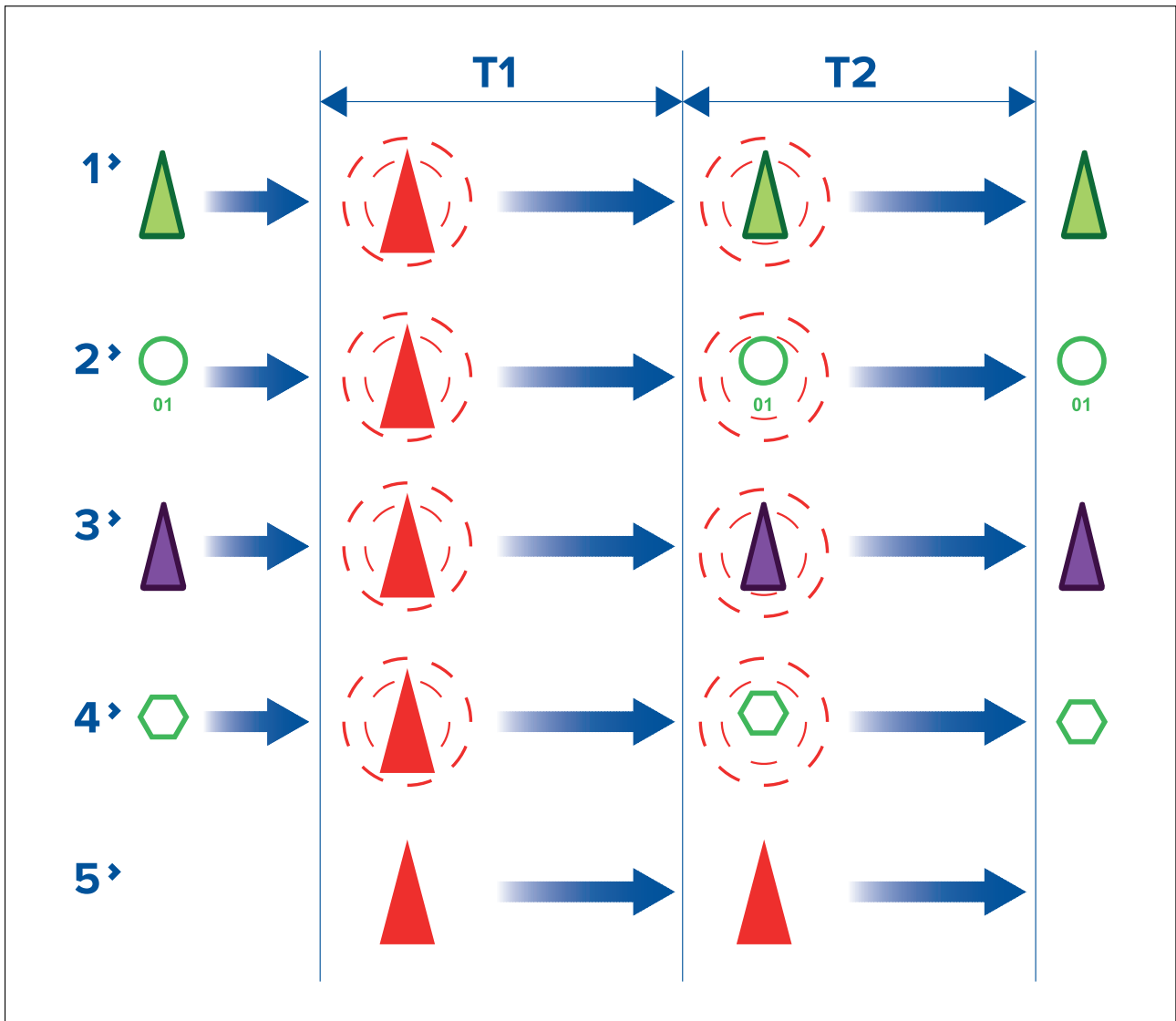

- **T1** Initial delay — The OneShot TOI icon is used to represent OneShot TOIs until an initial delay period has expired.
- **T2** Second delay — After the initial delay period has expired the TOI will revert to using its original target icon but maintain the Red dashed rings around the icon. After a second delay period expires the Red dashed circles are removed and the target reverts to using its original target icon. After the second delay period expires the target is no longer designated as a TOI.

1. AIS targets
2. Radar targets
3. Intel targets
4. DSC targets
5. Received TOI

Note:

Received OneShot TOIs use the standard received TOI icons for the duration of both delay periods and will then disappear.

TOI OneShot settings

TOI OneShot decay times and automatic repeat for sending / broadcasting the related STEDS message can be adjusted.

TOI OneShot settings are accessed from the **Advanced set-up** menu: **Homescreen > Settings > Responder > Advanced set-up > Configure**.

The following settings are available:

- **T1** — Number of seconds for the initial delay period.

- **T2** — Number of seconds for the second delay period.

TOI transmission rates

TOIs can be transmitted as either a single 'OneShot' transmission or as a recurring transmission.

TOIs generated from Intel targets or DSC targets are automatically assigned as OneShot TOIs. TOIs generated from AIS targets and Radar targets allow the sender to select the TOI rate when the TOI is created. Recipients and senders can change the TOI rate at anytime.

The following TOI rates can be selected:

- OneShot (Single Transmission) — TOI message is transmitted only once.
- Slow Target (600 sec repeat) — TOI message is transmitted every 600 seconds.
- Medium Target (180 sec repeat) — TOI message is transmitted every 180 seconds.
- Fast Target (60 sec repeat) — TOI message is transmitted every 60 seconds.
- Aircraft Target (15 sec repeat) — TOI message is transmitted every 15 seconds.

Note:

- A vessel can only send 1 recurring TOI message at a time. If a second recurring TOI message is sent out it will replace the first TOI message.
- A vessel can send out multiple OneShot TOI messages.
- A vessel can receive multiple OneShot and recurring TOI messages.
- TOI rates for Intel targets and DSC targets are always set as OneShot and cannot be changed.

TOI cancellation repeat

To ensure a TOI cancellation is received cancellations can be automatically repeated multiple times at a specified interval.

The cancellation repeat options are accessed from the Responder menu tab: **Homescreen > Settings > Responder > Advanced settings > Configure > CANCEL/UPDATE MESSAGES**. For following options are available:

- **Repeat** — Determines the number of times the TOI cancellation is transmitted.
- **Interval** — Determines the time interval between sending cancellation repeats..

TOI position updates

TOI positions are updated as follows:

- AIS targets and Radar targets will receive regular position updates from the relevant device.
- Intel targets will maintain their initially reported heading and speed
- DSC targets remain static, unless position reports are received.

Accessing target options

Target specific options are available for targets that are currently being tracked. The target options can be accessed from the target's context menu and from the Pop-over options in the relevant target list. The options available are dependent on the type of target.

To access a target's context menu:

- Press and hold on the target onscreen, or
- Highlight the target onscreen using the **Direction controls** and press the **OK** button.

To access the target list Pop-over menu:

- Select the target in the relevant target list, or
- Highlight the target in the list using the **Direction controls** and press the **OK** button.

TOI options

TOI options are available which change the status and details of a TOI. Changes to TOI options are sent and received over STEDS messaging.

Note:

Context menu options — In addition to the TOI options listed below, options relevant to the type of target the TOI originated from will also be available in the target context menu (i.e.: Radar, AIS, DSC or Intel).

- **Cancel TOI** — TOIs can be cancelled by selecting **Cancel TOI**.
 - Sent TOI — When a sender selects **Cancel TOI** the local TOI target icon will revert to its original target icon and the TOI is automatically cancelled for all recipients.
 - Received TOI — When a recipient selects **Request TOI cancellation** a cancellation request is sent to the originator and once acknowledged the TOI target icon will be removed or revert to its original target icon.
- **TOI description** — The type of vessel that the TOI target icon represents can be set or updated using the **TOI description** option. Changes are automatically updated for the sender and all recipients.
- **TOI status** — The status of the TOI can be set or updated using the **TOI status** option. Changes are automatically updated for the sender and all recipients.
- **Intercept** — Selecting **Intercept** initiates target interception for the selected target. For details see: [p.163 — Target intercept](#)
- **Centre on chart** — Selecting **Centre on chart** centres the TOI in the Chart app.
- **View related messages** — Selecting **View related messages** opens the STEDS messaging app and displays all related messages (messages that have the same link ID as the selected TOI).
- **TOI rate** — The rate of transmission can be changed for recurring TOIs by selecting **TOI rate** and then selecting the required rate.

Note: TOI rate for OneShot TOIs cannot be changed.

- **Clear lost TOI** — Selecting removes the TOI from the TOI list and either removes the TOI icon from the Chart app or reverts the target icon to its previous target icon.

TOI list

Targets currently designated as TOIs are listed in the TOI target list: The TOI list identifies: The Link ID created when the TOI was sent/broadcast. The Description, Originating vessel, Range and Bearing and the TOI status.

The TOI list can be accessed from the Targets menu in the Radar app and Chart app: **Menu > Targets > TOI**

Selecting a target from the list highlights the selected target in the LiveView app pane on the right of the page and opens the Pop-over menu.

TOI target list

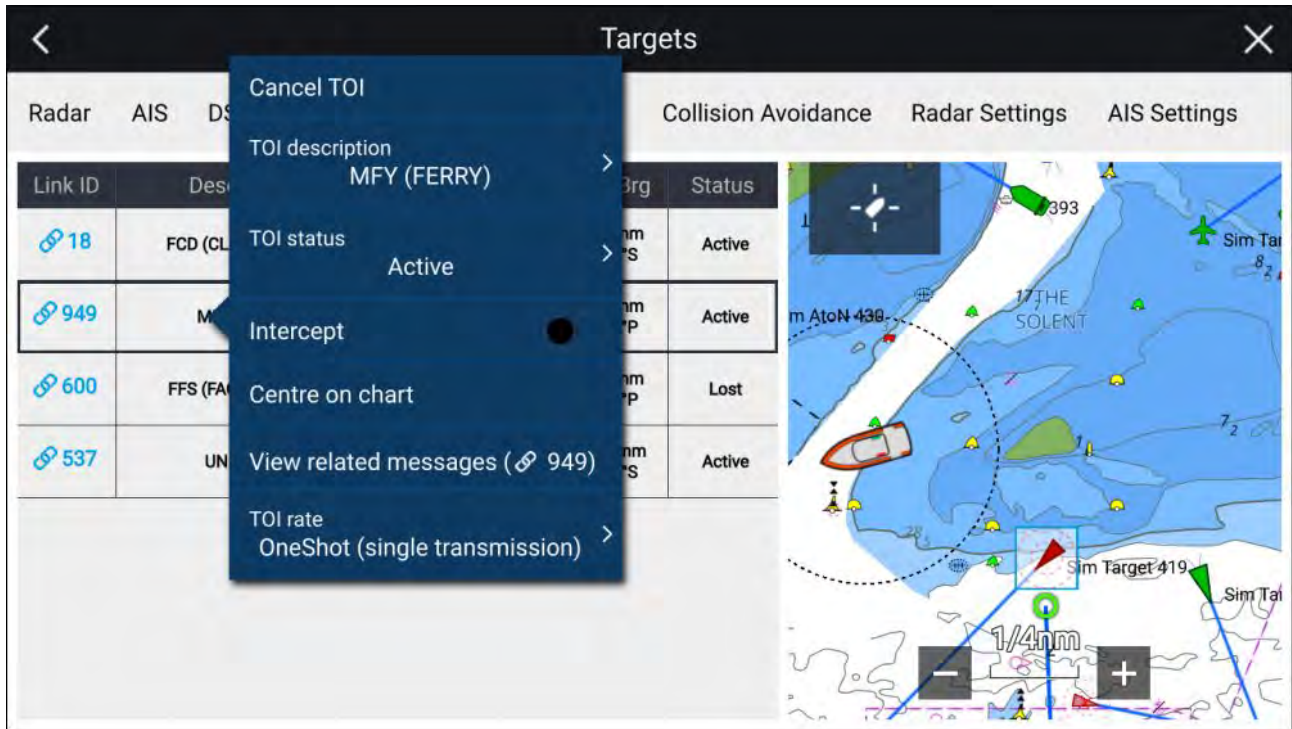

9.6 First responder AIS modes

With compatible STEDS AIS hardware connected the mode of the AIS hardware can be set from the MFD.

The AIS modes can be viewed and changed from the Status area in the Homescreen. Select the Status area and then select AIS to display and select available modes.

The AIS mode of the connected STEDs compatible AIS hardware will automatically be updated to match the selected mode.

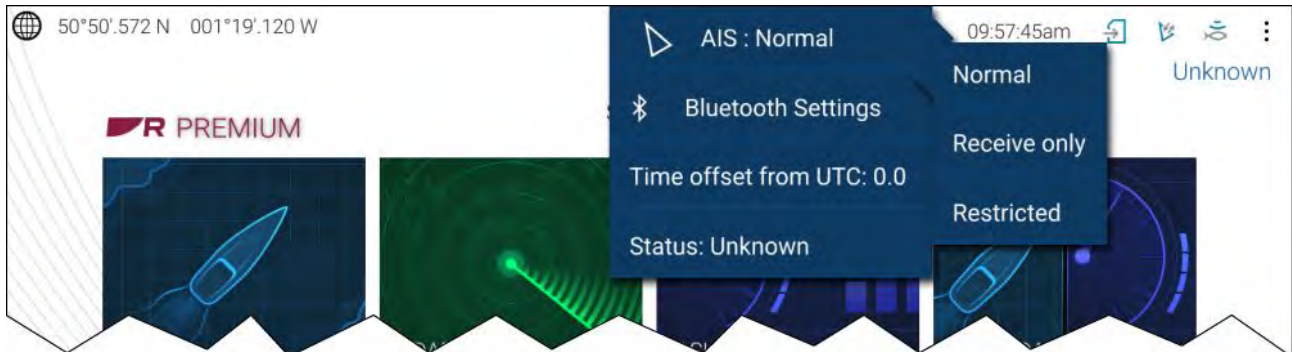

The following AIS modes are available:

- **Normal** — In this mode your AIS hardware will receive and transmit AIS messages and encrypted AIS messages.
- **Receive only** — In this mode your AIS hardware receives AIS messages and encrypted AIS messages, but transmits nothing (maintaining radio silence).
- **Restricted** — In this mode your AIS hardware will receive AIS messages and encrypted AIS messages, but only transmits encrypted AIS messages (no AIS messages are transmitted). This means vessels with 'standard' AIS receivers / transceivers will not be able to detect Blue Force vessels.

The AIS mode can also be changed from the **AIS Settings** menu: **Menu > Targets > AIS Settings > AIS mode** and from the Homescreen settings menu: **Homescreen > Settings > Responder. AIS mode**

Note:

AIS mode replaces the **Silent mode** option available on non-STEDS First responder configurations.

AIS mode status icons

Status icons are displayed in the Homescreen status area which identify the current AIS mode in use.

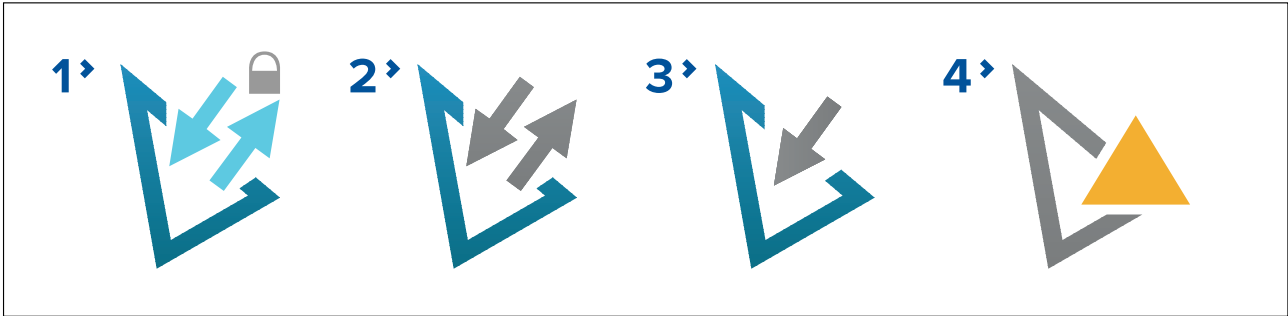



1. Restricted mode.
2. Normal mode.
3. Receive only mode.
4. Error.

Blue Force Tracking

Other vessels that are equipped with STEDS compatible AIS hardware, such as the AIS5000 are displayed onscreen using Blue Force AIS target icons.

The following icons are used:

	Blue Force vessel		Blue Force SAR
--	-------------------	--	----------------

The Blue Force icons are used as long as:

- your MFD has a matching First responder passphrase.
- you have received a SITREP from them within the last 6 minutes.
- their AIS mode is not set to Receive only.

If the above conditions are not met then the target icon will revert to using the standard, Green AIS target icon.

9.7 SITREP (Situation report)

SITREP status is transmitted and received over STEDS messaging so that other STEDS equipped vessels using the same STEDS passphrase can see your status and you can see their status.

The current SITREP status is displayed in the Status area of the Homescreen. The SITREP status can be changed by selecting **Status:** from the Status area Pop-over menu and then selecting a SITREP.

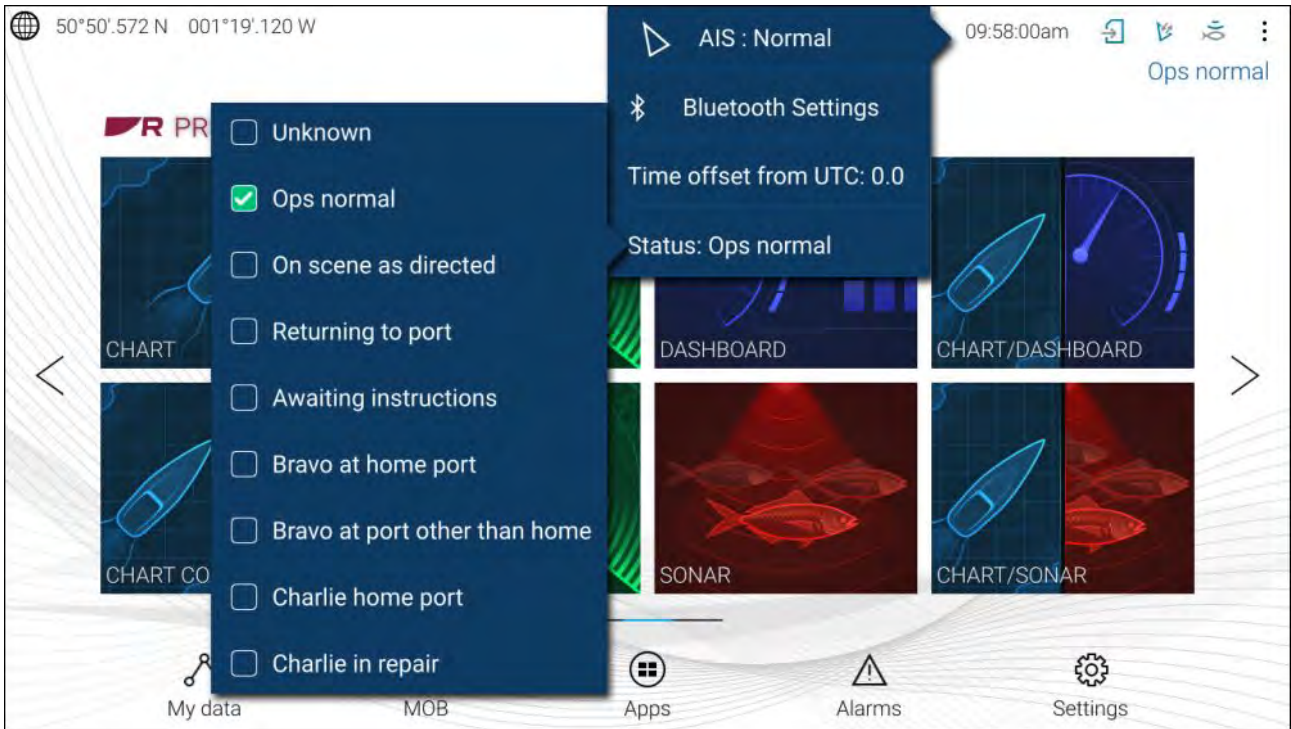

Note:

- SITREP status is transmitted every 15 seconds if a vessel is traveling at 3 knots or more.
- SITREP status is transmitted every 30 seconds if a vessel is traveling under 3 knots for more than 3 minutes.

The SITREP status of other vessels is displayed in the Blue Force Target's context menu in the Chart app and Radar app.

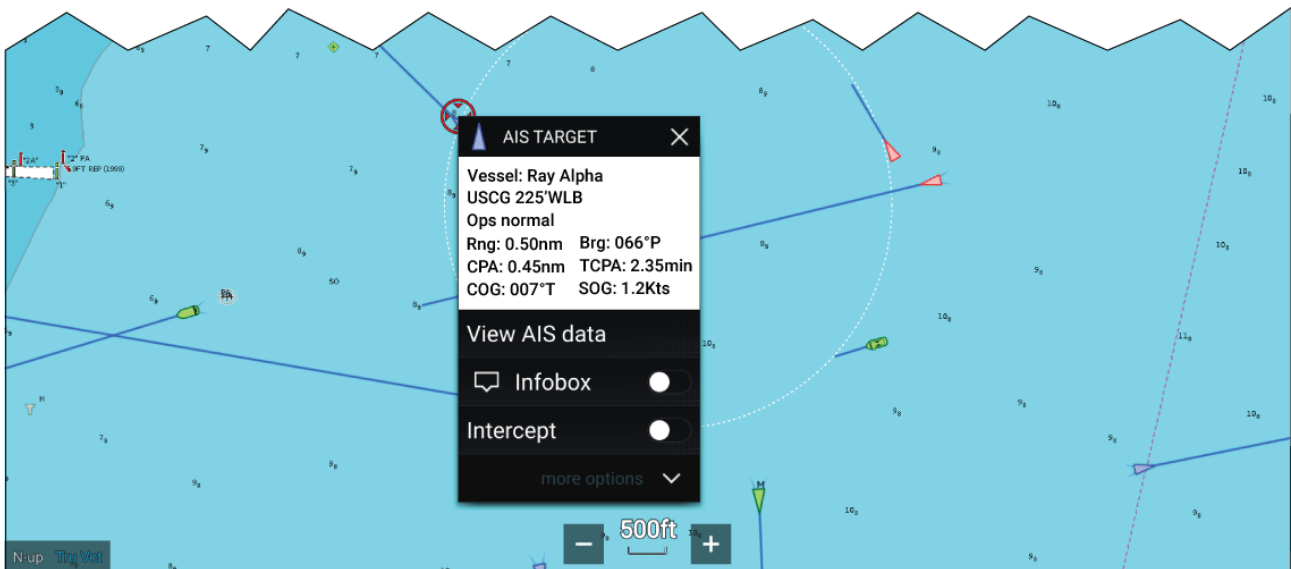

The MFD supports both current (FID 10) and legacy (FID 56) SITREPs.

Note:

- Blue Force targets using Legacy SITREP FID 56 are displayed using the Blue Force icons, however cannot be interacted with (i.e.: you cannot send or receive text messages, SAR patterns or TOIs).
- Blue Force targets using Legacy SITREP FID 56 can also be displayed when using an NMEA 0183 connection but cannot be interacted with.

9.8 SAR pattern receipt

SAR patterns can be received over STEDS messaging and imported so that it can be followed. When a SAR pattern is received a notification is displayed onscreen.



The notification provides details about the SAR pattern and the following options:

- **Import SAR Route** — Imports the SAR pattern as a router so that it can be followed.
- **Reply** — Allows you to send a new direct message to the sender.
- **View Inbox** — Opens the Messaging app.
- **Dismiss** — Dismisses the notification. The SAR pattern can still be imported from the Messaging app if required.

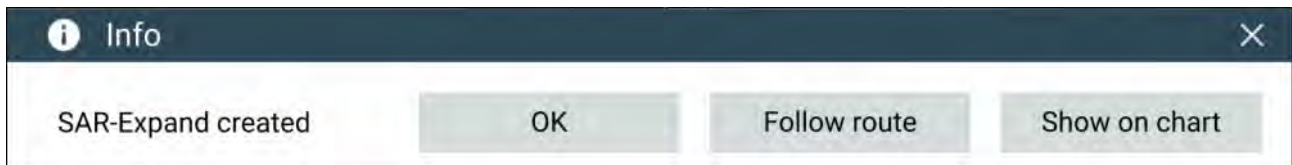

Once a SAR pattern is imported it can be followed by selecting **Follow route** or, if the Chart app is open it can be displayed onscreen by selecting **Show on chart**.

For more information about SAR patterns refer to: [p.175 — SAR \(Search and Rescue\) patterns](#)

9.9 Messaging

MFDs configured as 'First responder' which also have STEDs functionality can send and receive secure text messages with other properly equipped STEDs vessels.



When a message is received it is displayed onscreen in a dialog box. The dialogue will identify the sender, the link ID and display the message.

The following options are available on the Message dialog:

- **OK** — Dismisses the Dialog (The message will be saved in the Messages inbox).
- **Reply** — Opens the onscreen keyboard so that a reply can be sent.

Sent and received messages are stored in the Messages inbox.

The Messages inbox can be accessed by creating a Messages app page on the Homescreen or from the **My data** menu: **Homescreen > My data > Messages**.

Message inbox

The inbox stores all direct messages and broadcasts that you have sent and received from other responder vessels.

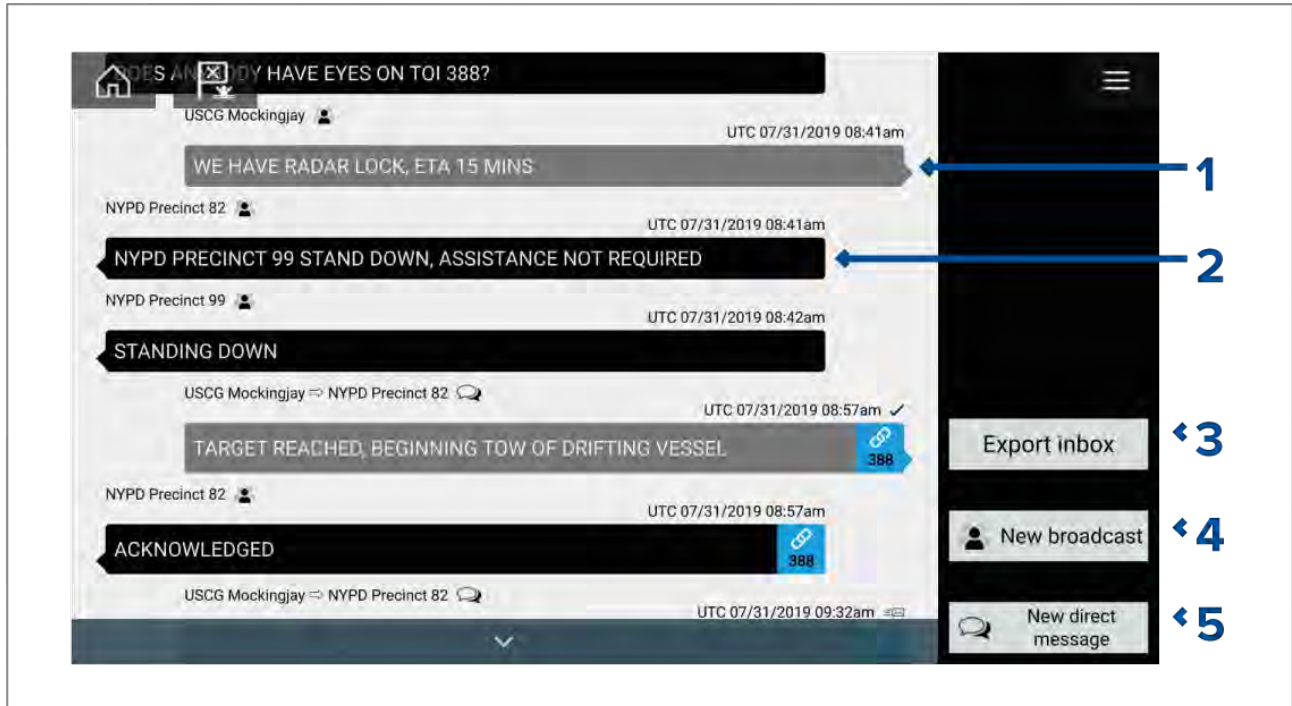

1. **Sent** broadcasts and direct messages (white, right side).
2. **Received** broadcasts and direct messages (grey, left side).
3. **Export inbox** — Exports the current view / filter of messages to a .csv (Comma Separated Values) spreadsheet file to a memory card inserted in the MFD's card reader. The Export inbox option is only available when a memory card is present in the MFD's card reader.
4. **New broadcast** — Send a broadcast to all responder vessels.
5. **New direct message** — Send a direct message to a specific responder vessel.

Note:

Messages older than 72 hours will be removed from the inbox after a power cycle.

New broadcast

A new message can be broadcast to all responder vessels with the same STEDs passphrase.

Selecting **Broadcast message** from the Chart app's **New** menu or selecting **New broadcast** from the Messages inbox opens the onscreen keyboard where you can enter your message. When you are happy with your message select **Send** to broadcast the message.

Note:

Inbox messages have a 57 character limit per message.

New direct message

A new direct message can be sent to specific vessel using its MMSI number or to an AIS vessel designated as a 'Buddy'.

Selecting **Direct message** from the Chart app's **New** menu or selecting **New direct message** from the Messages inbox opens the **Recipient** page where you can select **Recent** contacts (recent message senders and recipients) and **Buddy** contacts or you can enter the MMSI number of a vessel you want to send a direct message to.

Select a recent or buddy contact and select **Next** to open to the onscreen keyboard where you can enter your message. When you are happy with your message select **Send** to send the message. or, Select Enter MMSI to enter a new MMSI number then select **Next** to open to the onscreen keyboard where you can enter your message. When you are happy with your message select **Send** to send the message.

Direct message Blue Force targets

A direct message can be sent to Blue Force targets in the Chart app and Radar app.

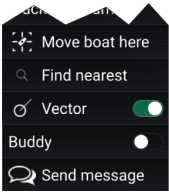

Open the Blue Force target's context menu and select **Send message** to open to the onscreen keyboard where you can enter your message. When you are happy with your message select **Send** to send the message.

For more information on Blueforce AIS targets, refer to: [p.220 – Blue Force Tracking](#)

Reply to messages

You can reply to direct messages and broadcasts from the **Inbox**.

To reply, perform a long hold on a received direct message or broadcast until the context menu appears:

- **Reply** — Reply to a direct message with a direct message.
- **Broadcast reply** — Reply to a broadcast with a broadcast.
- **Reply / Broadcast reply (with Link ID)** — Reply to a direct message or broadcast that has a link ID by responding with a direct message or broadcast that contains the same link ID.

Onscreen keyboard

Use the onscreen keyboard to type your messages. Messages can contain a maximum of 57 characters.

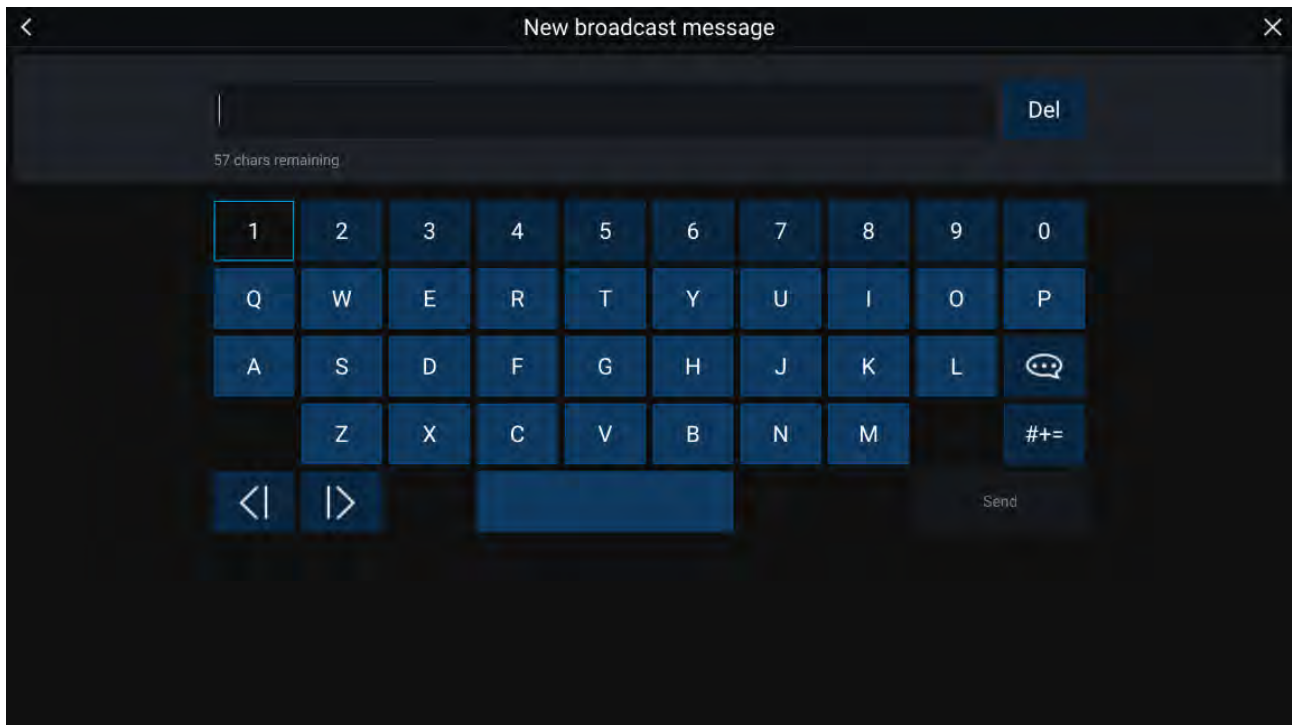







Selecting the **Template Text** icon will change the onscreen keyboard to a list of template messages that can be quickly added to the message when selected. Selecting **My Position** will enter your vessel's current coordinates into the message.

Note:

Coordinates entered into the message display degrees as **'DEG'**.

Message symbols

Symbols attached to messages in the **Inbox** indicate its type and status.

	<p>Broadcast — A broadcast to all other responder vessels.</p>
	<p>Direct message — A direct message to a specific responder vessel.</p>
	<p>Sender — Indicates the sender (left of the arrow) and recipient (right of the arrow) of a direct message.</p>
	<p>Message sent — Direct message has been sent and acknowledged by the recipient's hardware.</p>
	<p>Message sending — Direct message is still waiting to be acknowledged as successfully received by the recipient's hardware.</p> <p>Note: A maximum number of 4 attempts will be made to send the message by the sender's hardware, with 150 seconds of separation between each attempt.</p>
	<p>Message failed to send — Direct message has failed to be acknowledged by the recipient's hardware.</p> <p>Note: The failed message will remain in the Inbox.</p>
	<p>Link ID — A link ID generated and used by responder vessels.</p> <p>Note: Replying to a direct message or broadcast that has a link ID will send a reply that contains the same link ID.</p>

Chapter 10: Weather mode

Chapter contents

- [10.1 Weather mode on page 228](#)
- [10.2 Activating your SiriusXM receiver on page 229](#)
- [10.3 Animated weather on page 230](#)
- [10.4 Weather mode context menu on page 231](#)
- [10.5 Weather Radar layer on page 231](#)
- [10.6 Cities and Surface observation stations layers on page 233](#)
- [10.7 Cloud top and Lightning layers on page 234](#)
- [10.8 Storm cast and Storm tracks layers on page 235](#)
- [10.9 Sea surface temperature and Surface pressure layers on page 236](#)
- [10.10 Wind and Watchbox layers on page 238](#)
- [10.11 Wave direction, height and period layers on page 239](#)

10.1 Weather mode

Weather mode is available in the Chart app if you have a weather receiver and valid subscription. Switching the Chart app to weather mode allows you to overlay weather data and information from your weather receiver.

To enter Weather mode, open the Chart app menu and select **WEATHER**.

Weather mode allows you to track weather systems in relation to your vessel by overlaying live, historical and forecasted weather data directly on the chart. In Weather mode you can also view animated weather graphics and read weather reports. Weather mode sets the **Chart detail** setting to Low and hides other data which increases the visibility of Weather data.

Important:

- Compatible hardware and a valid subscription is required to enable Weather mode.
- By enabling Weather mode you agree to its terms of use.
- Do not use Weather mode for navigation.
- Weather data is only available in North America and its coastal waters.

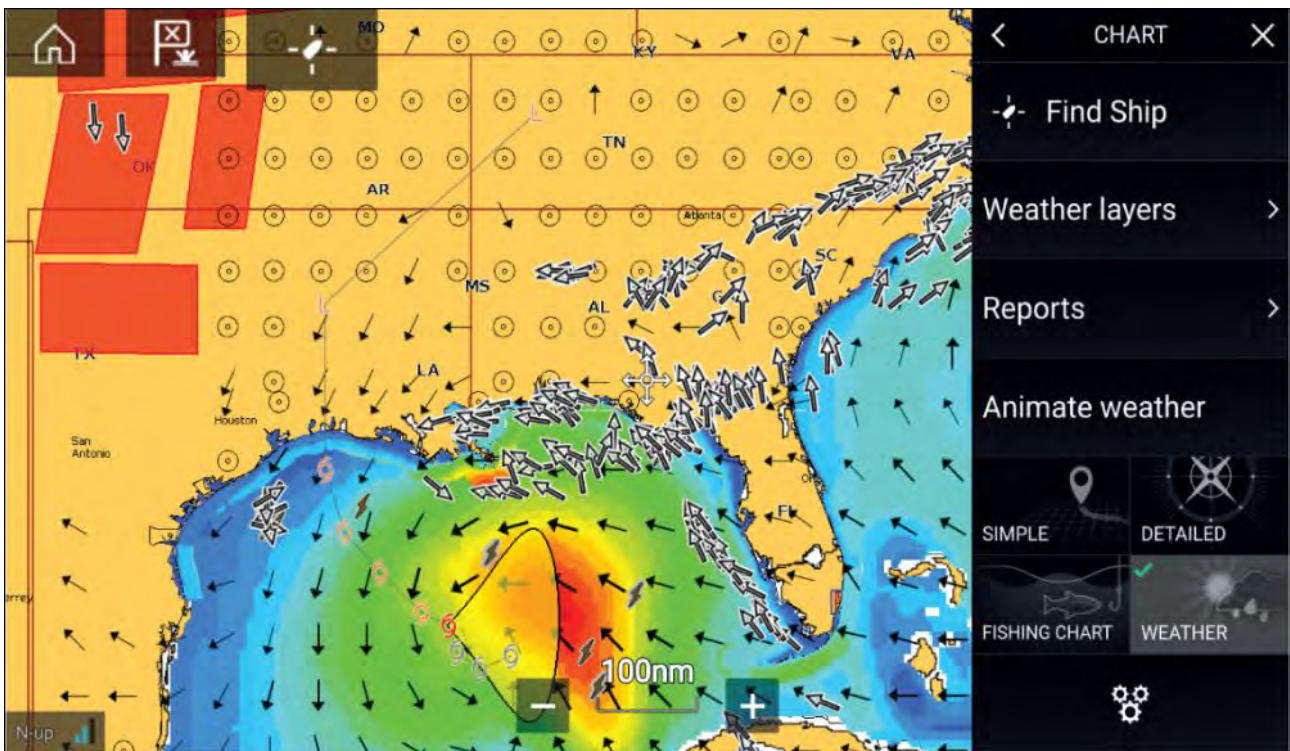

Weather symbols are organized into layers, accessible from the Chart menu: **Menu > Weather layers**. Each layer can be enabled and disabled independently.

The following Layers are available:

Weather radar	Surface pressure
Cities	Surface observation stations
Cloud top	Wind
Lightning	Watchbox
Sea surface temperature	Wave height
Storm cast	Wave period
Storm tracks	Wave direction

In Weather mode the **Chart orientation** is fixed in **North-Up**.

10.2 Activating your SiriusXM receiver

Your MFD is compatible with the SR150 and SR200 SiriusXM receivers. Your receiver must be activated before you can use Weather mode on your MFD.

Note:

Lighthouse Software Version

- LH3.10 – SR200 SiriusXM receiver for Weather mode is compatible on all Axiom Multifunction Displays on the same network as the data master.

The following information is required to activate your SiriusXM receiver:

- Electronic Serial Number (ESN) — The ESN is printed on the product label located on the underside of your SiriusXM receiver. You can also access the ESN from the Weather settings tab in the Chart app: (**Menu > Settings > Weather > Receiver ESN**).
 - Current billing information (if you already have a valid subscription).
 - Desired subscription package.
1. Obtain your SiriusXM receiver's ESN.
 2. Visit the Sirius Marine Weather website: <http://www.siriusxm.com/sxmmarine>, and choose a subscription package.
 3. Follow the "Activate Now" link to activate your receiver online. Alternatively, call 1-855-796-9847.

Once your SiriusXM receiver is activated, you will be able to enable Weather mode and display Weather layers in the Chart app. To enable Weather mode, open the Chart app and select **WEATHER**.

SR200 diagnostics mode

The SR200 diagnostic mode can be accessed from the audio settings menu from the master MFD on the network. The diagnostics mode should be referred to when liaising with Sirius product support.

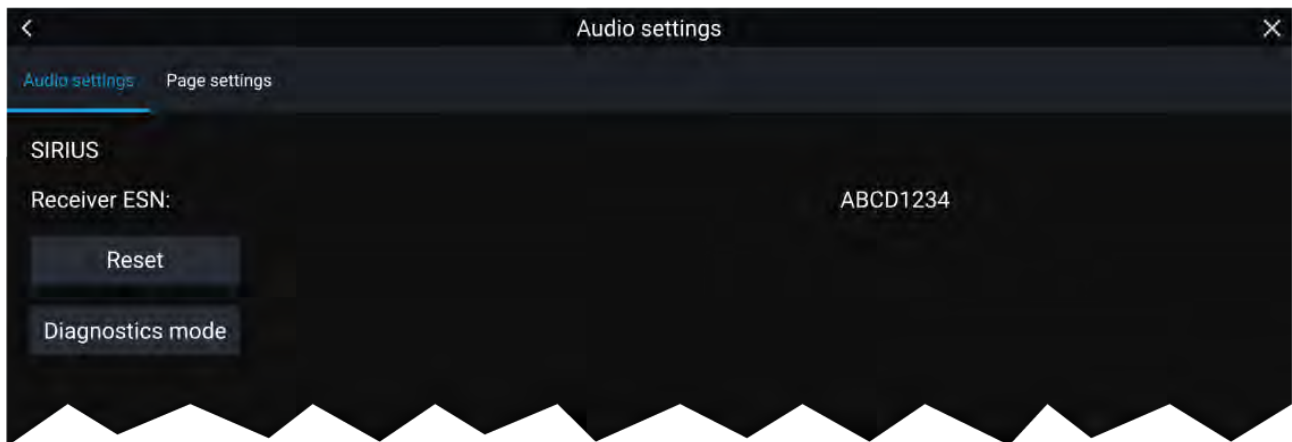

1. Reset — Performs a factory reset and power cycle of the SR200.
2. Diagnostics mode — Displays the SR200's diagnostic information.

Weather receiver status

The status of your weather receiver is displayed in the app info area in the bottom left of the screen.



The app info area displays:

- chart orientation mode — (N-up) orientation is fixed in weather mode.
- signal strength of your Weather receiver:

- Animated dots = no signal; searching for signal.
- 1 bar (orange) = poor signal strength.
- 3 bars (blue) = good signal strength.
- time and date related to the weather data being displayed.

10.3 Animated weather

In Weather mode you can play weather animations of historical **Weather radar** data and forecasted wind, wave and surface pressure data.

Weather animations can be accessed in Weather mode by selecting **Animate weather** from the menu.

When Animate weather is selected the animation player controls and symbols representing the type of animated data available are displayed onscreen.







Player controls

Player controls include a progress bar, Play/Pause, Fast forward and rewind options.

Animated weather data

Duration of forecasts are dependent on subscription type.

	<p>Weather Radar Historical precipitation data for the previous 2 hours can be played.</p>
	<p>Wind Offshore wind forecast for up to 48 hours. High resolution coastal and inland wind forecast for up to 24 hours.</p>

	<p>Wave height Offshore wave height forecast for up to 48 hours. High resolution coastal wave height forecast for up to 24 hours. Great Lakes wave height forecast for up to 24 hours.</p>
	<p>Wave period Offshore wave period forecast for up to 48 hours. Great Lakes wave period forecast for up to 24 hours.</p>
	<p>Wave direction Offshore wave direction forecast for up to 48 hours. Great Lakes wave direction forecast for up to 24 hours.</p>
	<p>Surface pressure Surface pressure forecast for up to 48 hours.</p>

To exit Animate weather open the main **Menu**.

10.4 Weather mode context menu

The Weather context menu provides Lat/Lon and Range and Bearing information, relative to your vessel. The context menu also provides access to further weather-related data.

	<p>The context menu provides access to:</p> <ul style="list-style-type: none"> • Weather info • Reports. <p>Depending on the symbol selected, the context menu also provides additional data when the Cities, Storm cast, Storm tracks or Watchbox option is selected.</p>
---	--

10.5 Weather Radar layer

With the Weather Radar layer enabled a color coded Radar image is displayed. This image shows a complete view of any precipitation across North America, including the type and intensity. Rain is shown as light green, dark green, yellow, orange and red as intensity increases. Hail, freezing rain

and snow are represented with colors from bright pink to blue. The images are displayed as pixels on screen and the resolution of this feature is 2 km per pixel. Coverage includes the Continental US, Canada, and portions of Mexico/Caribbean.

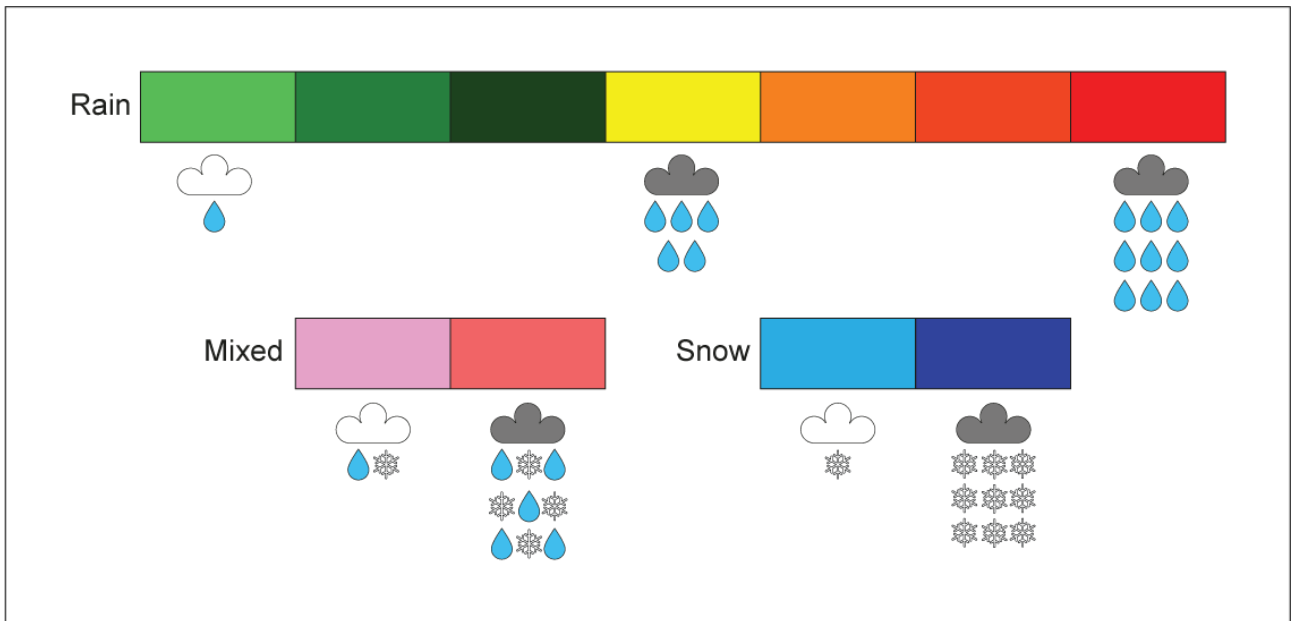
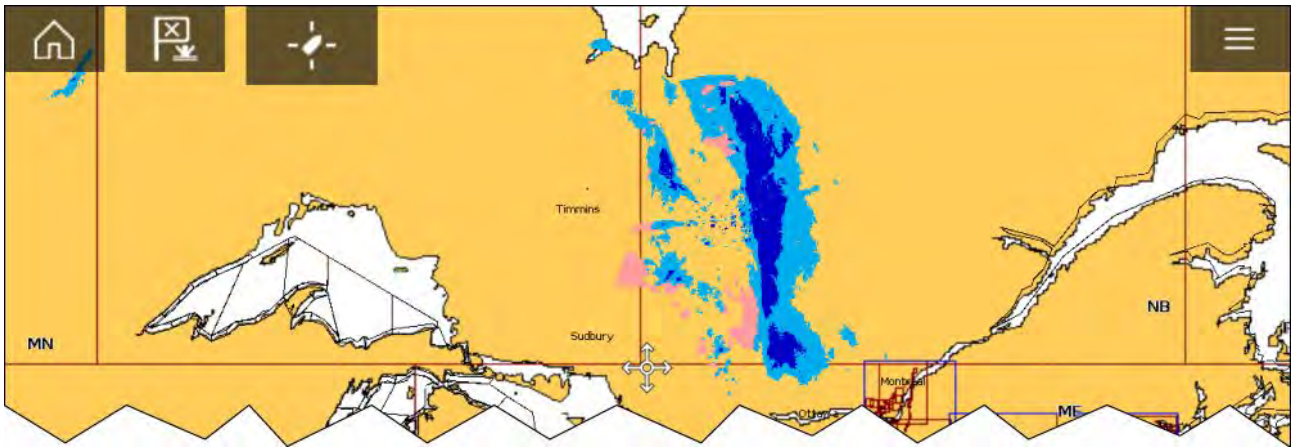

10.6 Cities and Surface observation stations layers

The Cities layer and Surface observation stations layer display symbols which represent the location of Cities and Surface observation stations respectively. The symbols used for Surface observation stations also identify the station type.

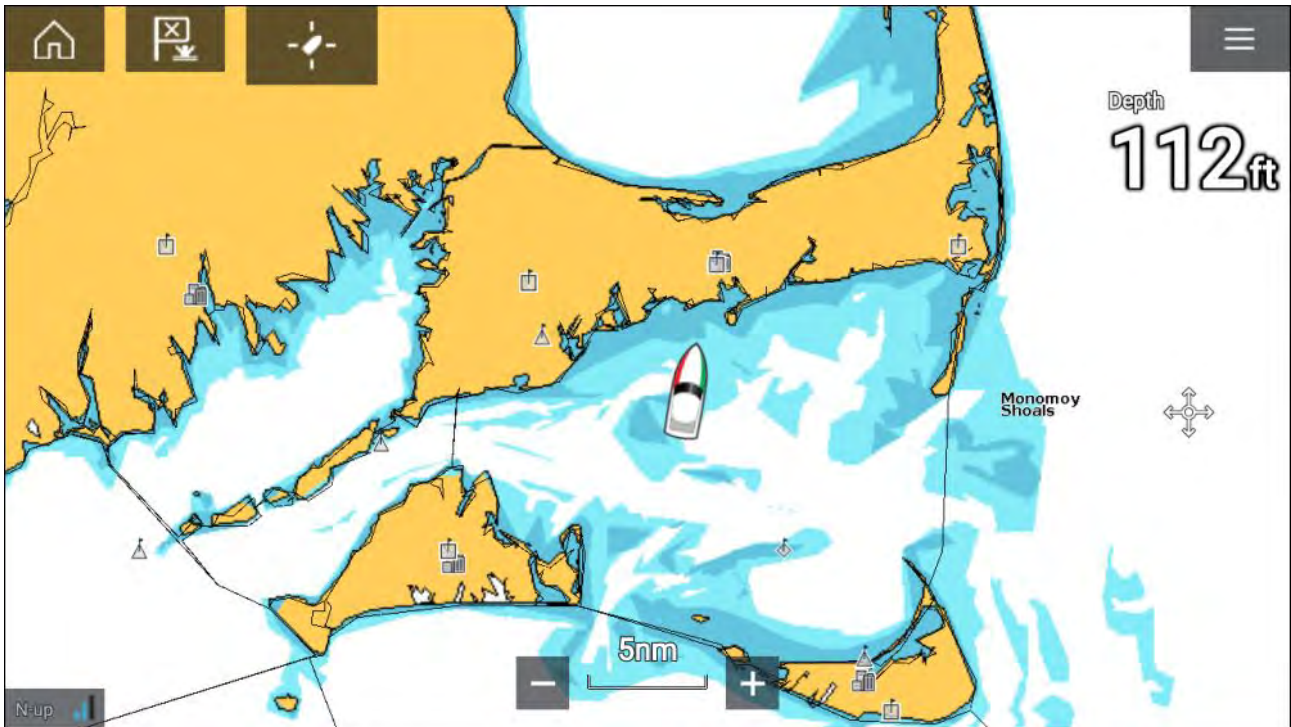

City forecasts are available from the context menu when a City is selected.

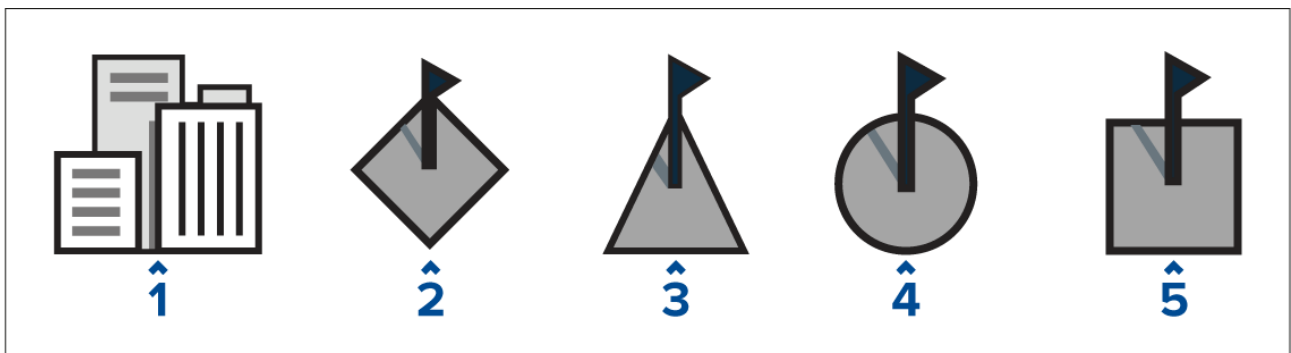

	Layer	Description
1	Cities	City
2	Surface observation station	Buoy station
3	Surface observation station	Coastal-marine automated network (C-MAN)
4	Surface observation station	Weather services international (WSI)

10.7 Cloud top and Lightning layers

The Cloud top layer provides a satellite image of current cloud coverage and the Lightning layer provides symbols to show the location of recent lightning strikes.

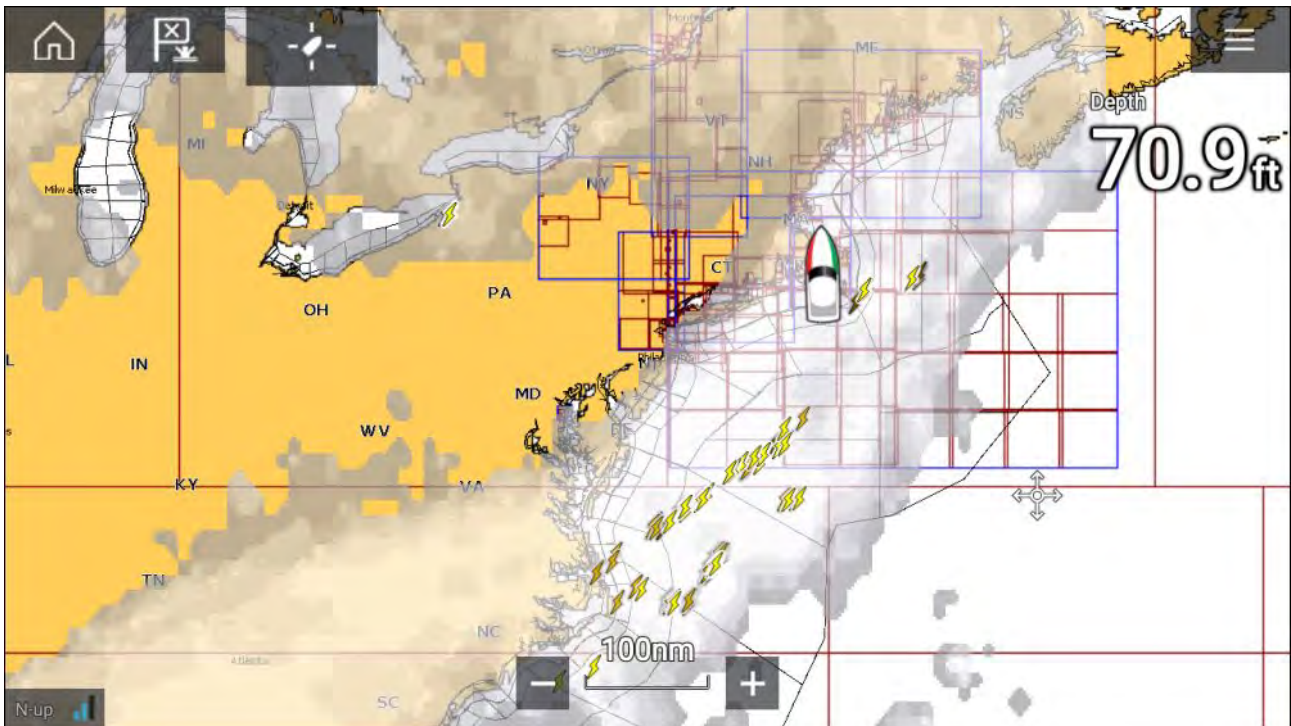

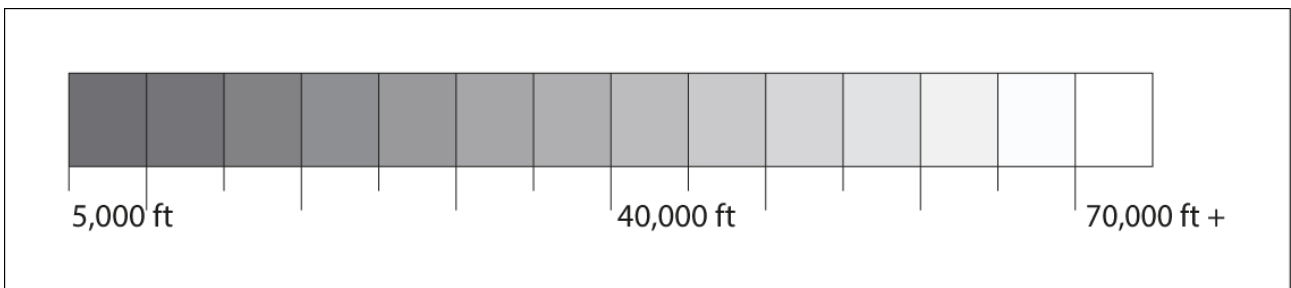

Cloud tops

Cloud tops use Gray shading to identify cloud top height. The shading changes at 5,000 feet increments, from Dark Gray to White. Clouds lower than 5,000 feet are not displayed.



Lightning

The shade of the lightning symbols represent the time the lightning strike was detected.

		
0 to 5 minutes ago	5 to 10 minutes ago	10 to 15 minutes ago

- **Pink** — wind speed = 64 knots or greater.
- **Orange** — wind speed = 50 knots or greater.
- **Yellow** — wind speed = 34 knots or greater.

10.9 Sea surface temperature and Surface pressure layers

The Sea surface temperature layer uses color coding to identify water temperature. The Surface pressure layer uses standard pressure patterns and Isobars to identify surface pressure.

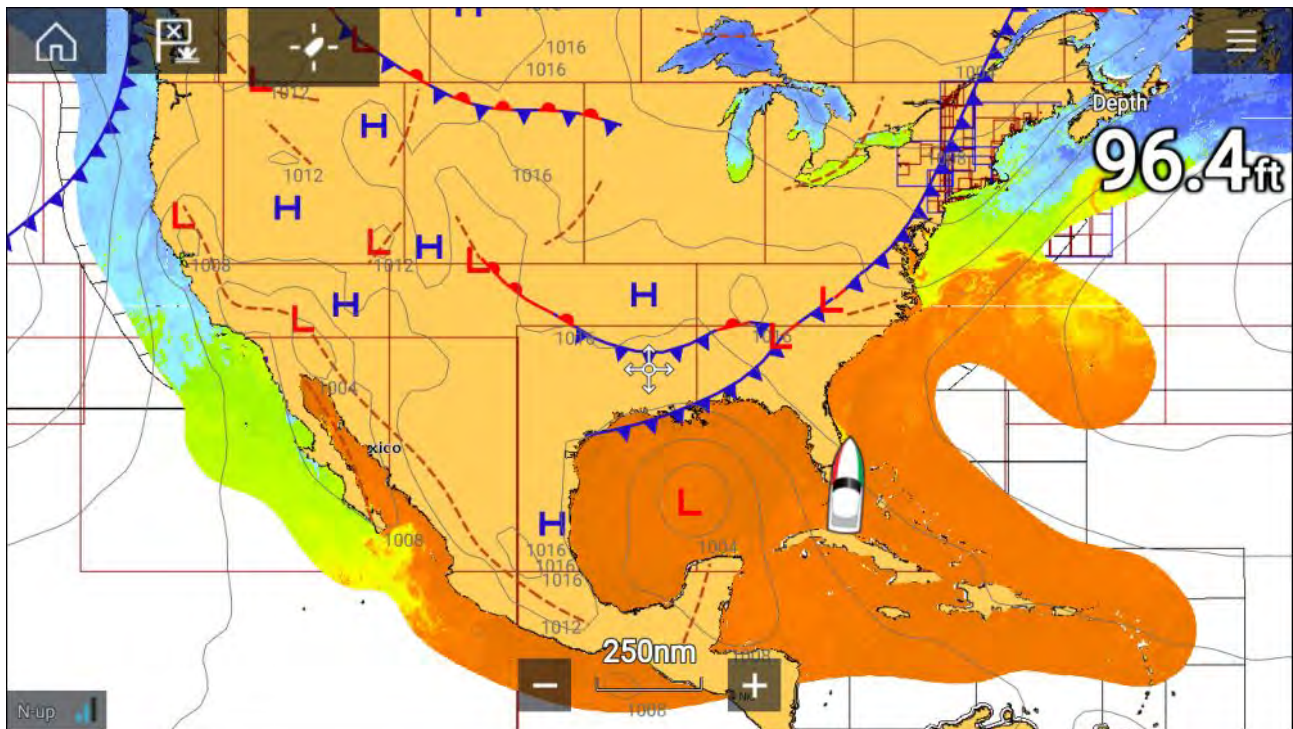





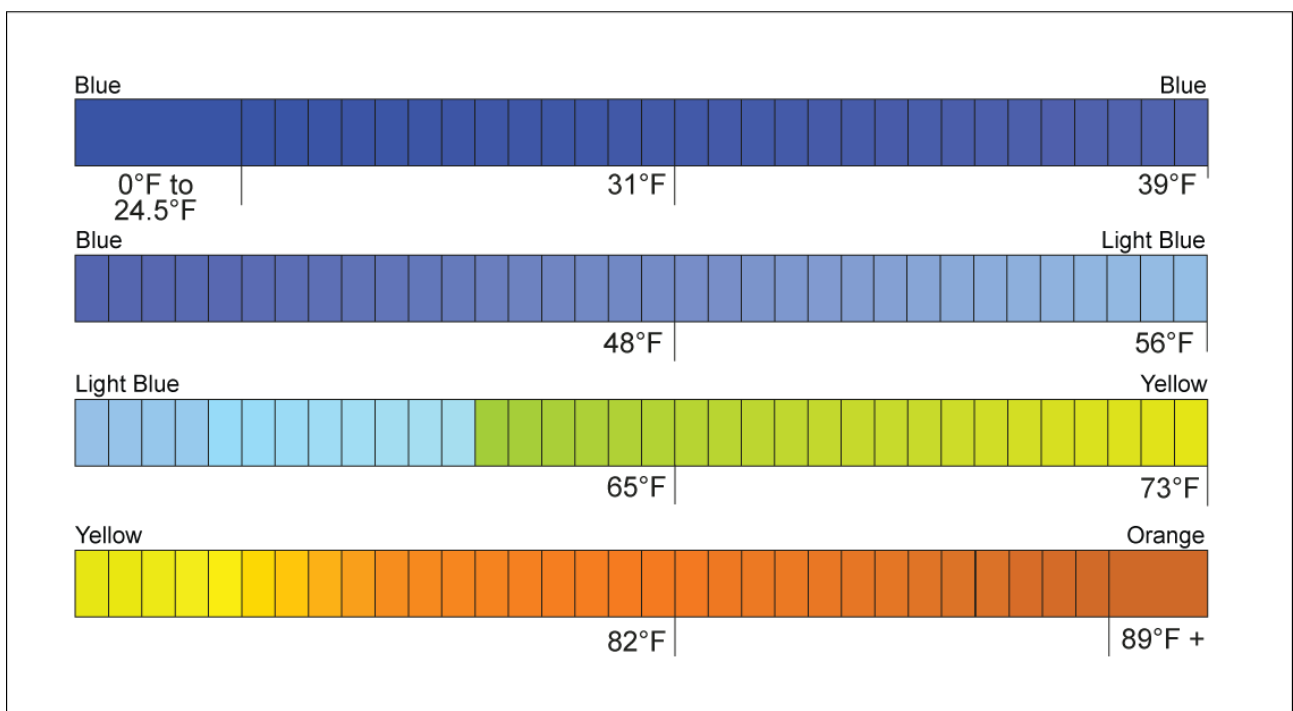



Sea surface temperature color coding

The colors used for the Sea surface temperature are shown below:



Surface pressure patterns

The Surface pressure layer uses standard meteorological patterns to represent surface pressure conditions.

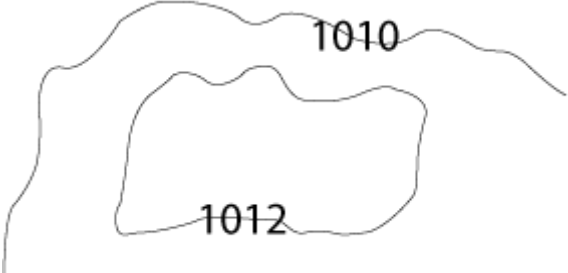
Symbol	Description
 <p>A diagram showing a high-pressure system on the left, represented by a red 'H' and a low-pressure system on the right, represented by a blue 'L'. Both are surrounded by curved lines representing isobars.</p>	<p>High / low pressure (Blue and Red)</p>
 <p>A red semi-circular line with semi-circles pointing towards the center of the curve.</p>	<p>Warm front (Red)</p>
 <p>A blue line with triangles pointing towards the center of the curve.</p>	<p>Cold front (Blue)</p>
 <p>A purple line with semi-circles on one side and triangles on the other, both pointing towards the center of the curve.</p>	<p>Occluded front (Purple)</p>
 <p>A line with alternating semi-circles and triangles pointing towards the center of the curve, one in red and one in blue.</p>	<p>Stationary front (Red-Blue)</p>
 <p>A dashed brown line forming a shallow curve.</p>	<p>Trough (Brown)</p>
 <p>A dashed red line with small squares along its length.</p>	<p>Squall line (Red)</p>
 <p>A red line with semi-circles pointing towards the center of the curve.</p>	<p>Dry line (Red)</p>
 <p>A diagram showing two irregular closed lines representing isobars. The inner line is labeled '1012' and the outer line is labeled '1010'.</p>	<p>Isobars (Gray)</p>

10.10 Wind and Watchbox layers

The Wind layer uses Arrows or Barbs to identify wind direction and speed. The Watchbox layer identifies areas where severe weather is occurring or forecast within a specified range.

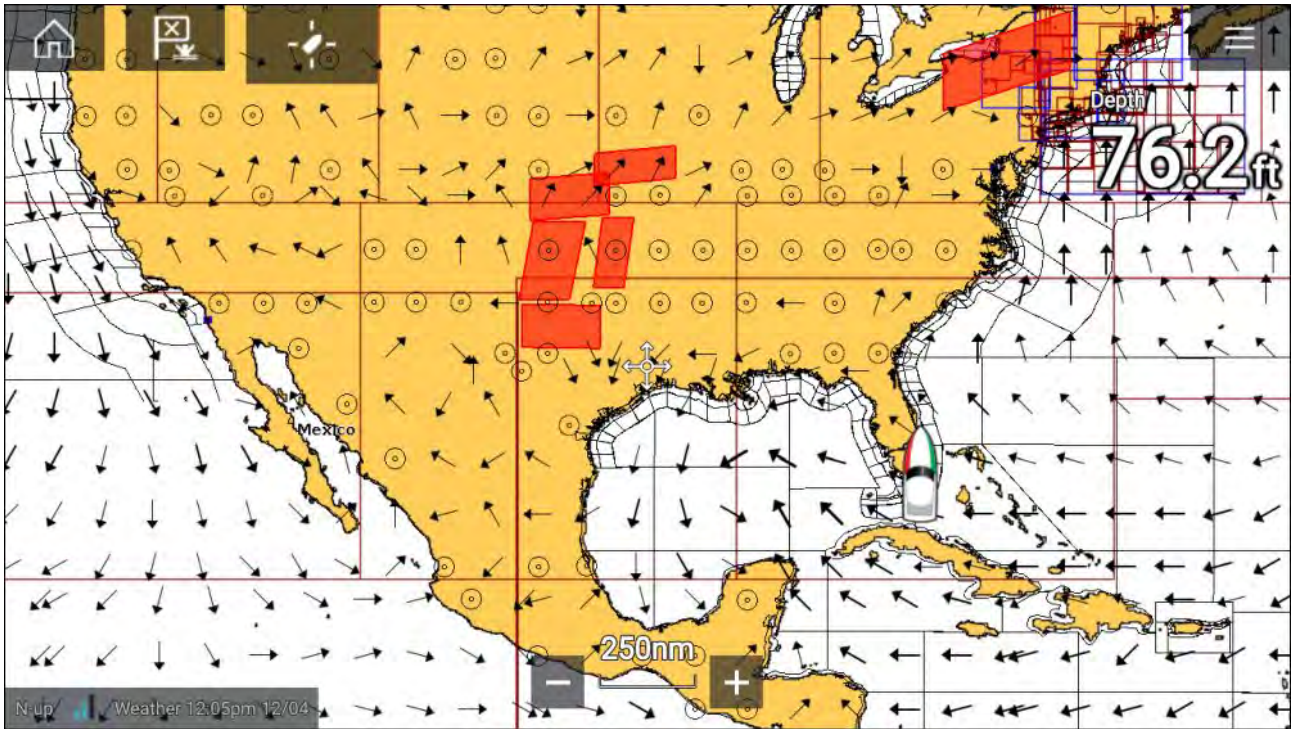

Wind arrows

The direction of the arrow indicates wind direction and the size of the arrow indicates wind speed, the larger the arrow the greater the wind speed. Where conditions are calm a circular symbol is used.

You can switch between using Arrows or Barbs for Wind data from the Weather tab of the Chart menu: **Menu > Settings > Weather > Wind symbol.**

Wind barbs

Wind barbs identify wind direction and speed.

Barbs provide a more accurate speed resolution than arrows.

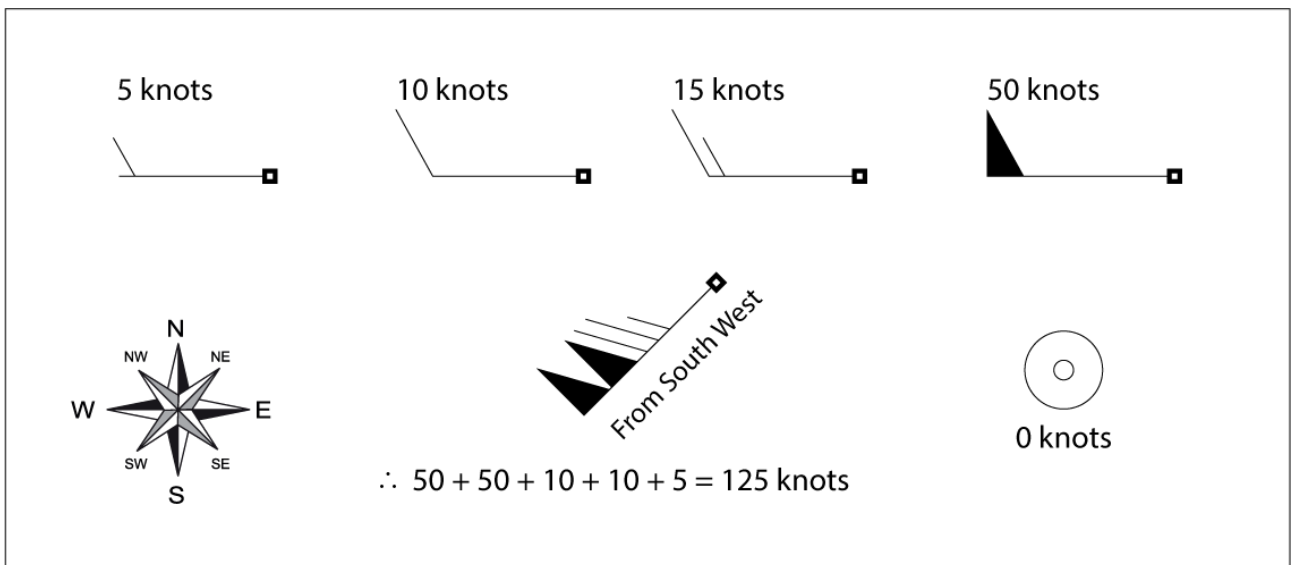

Adding the half barbs, full barbs and flags together provides wind speed. The direction the barbs point towards indicates where the wind is coming from.

- Half barbs = 5 knots
- Full barbs = 10 knots
- Flag = 50 knots

Watchbox

Selecting Watchbox data from the Weather context menu display the data associated with the Watchbox alert.

Watchbox alerts can be enabled and disabled from the Chart menu: **Menu > Settings > Weather > Watchbox alerts.**

You can also adjust the area that is monitored for Watchbox alerts using the **Watchbox range** control on the **Weather** tab.

10.11 Wave direction, height and period layers

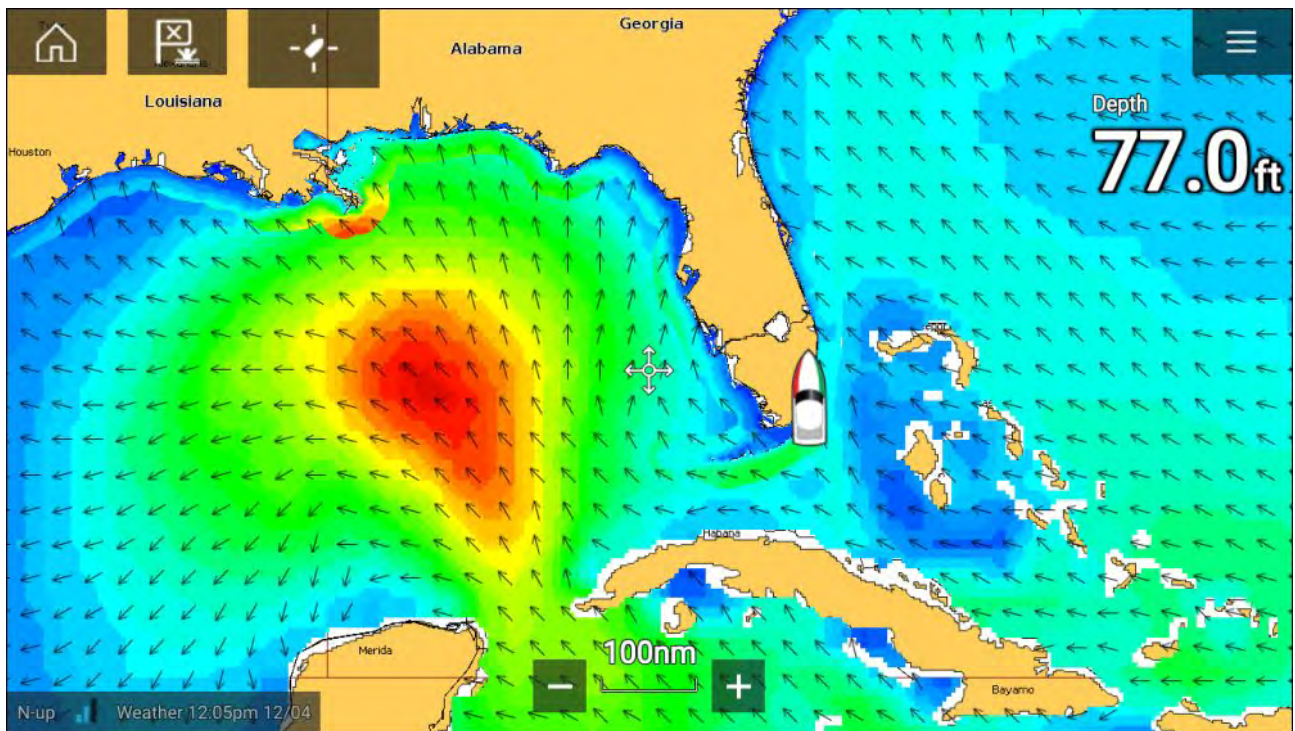

Wave direction

The **Wave direction** layer uses arrows to identify the direction of waves.

Wave height

Wave height uses colors to identify the height of waves. The colors used are as follows:

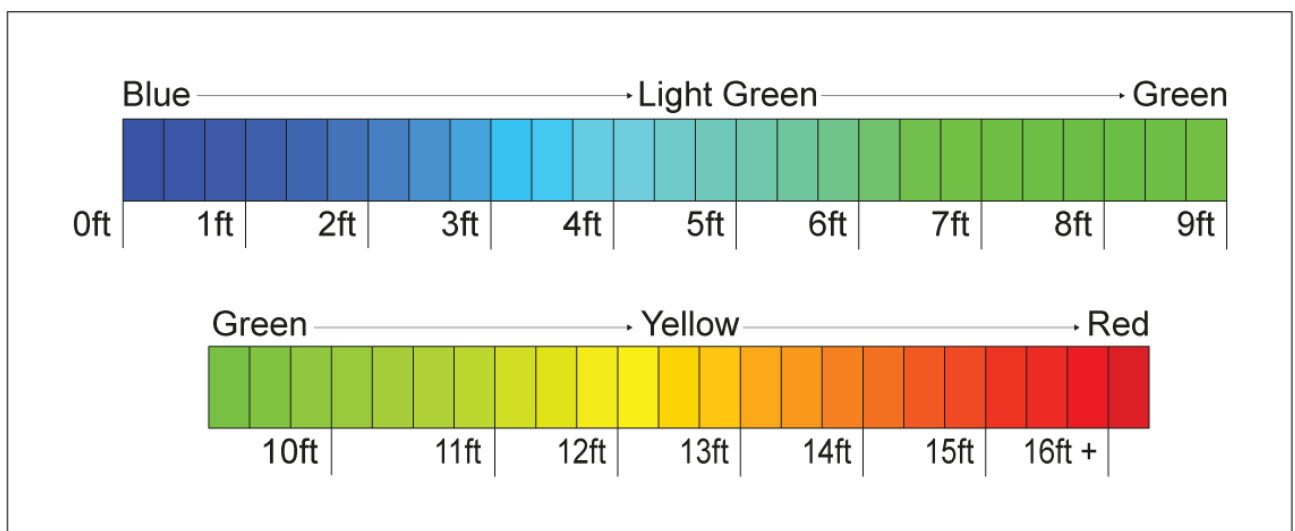

Wave period

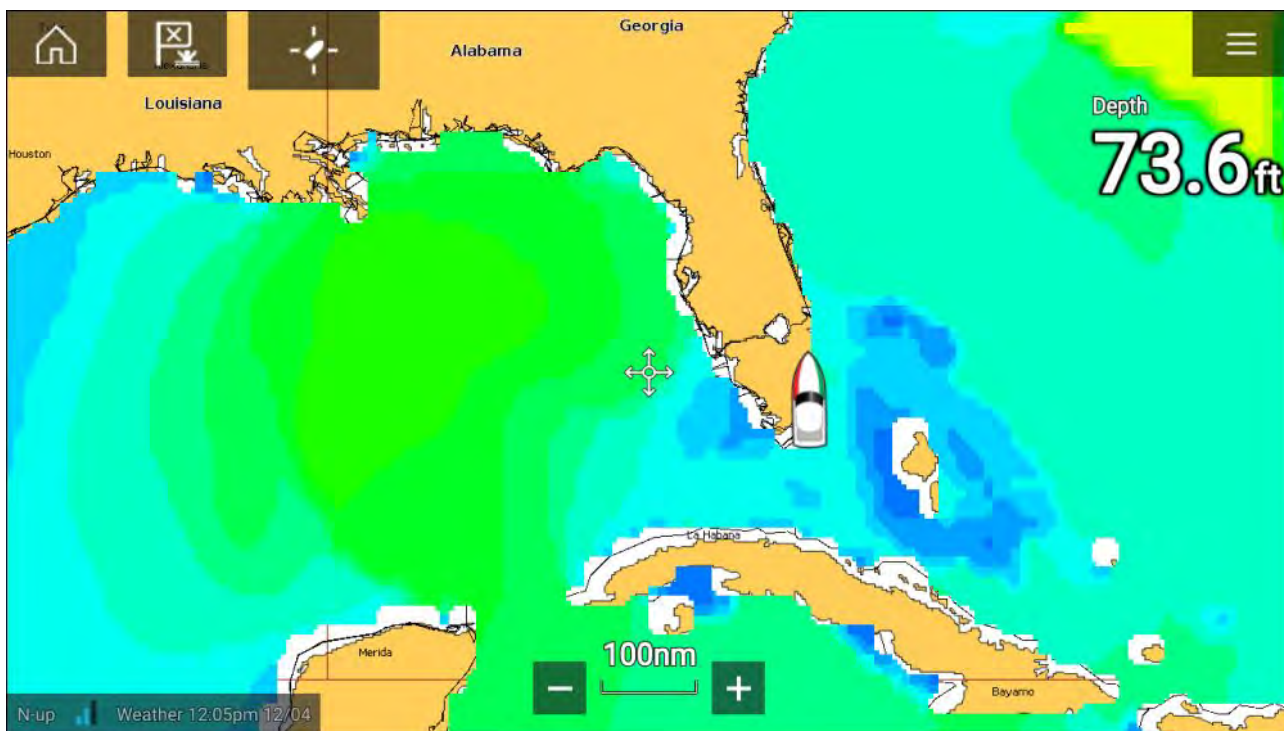

Wave period uses colors to identify the gap between successive waves. The colors used are as follows:

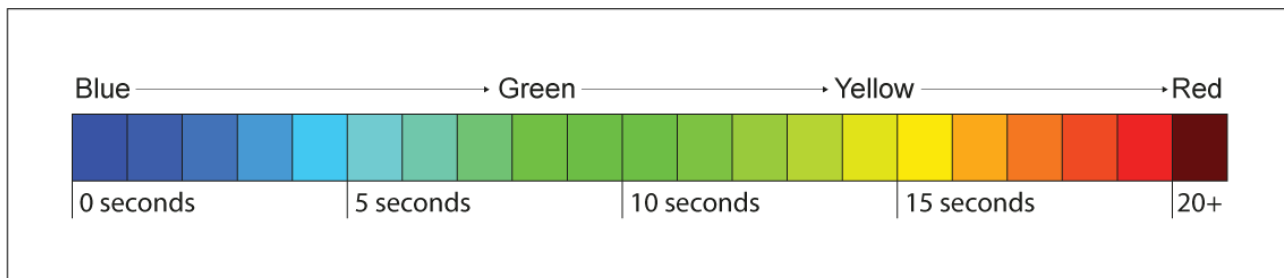

Chapter 11: Fishfinder app

Chapter contents

- [11.1 Fishfinder app overview on page 242](#)
- [11.2 Opening the Fishfinder app on page 244](#)
- [11.3 Sonar channels on page 246](#)
- [11.4 Placing a Waypoint \(Sonar, DownVision and SideVision\) on page 247](#)
- [11.5 Sonar scroll back on page 248](#)
- [11.6 Sonar sensitivity controls on page 249](#)
- [11.7 Fishfinder settings menu on page 250](#)

11.1 Fishfinder app overview

The Fishfinder app displays a visualization of the echoes received from a Sonar module and transducer. The Fishfinder app is compatible with Traditional, CHIRP, DownVision™, SideVision™ and RealVision™ 3D sonar modules and transducers. The Fishfinder app builds an underwater view of bottom structure and targets in the water column.



Multiple Sonar modules can be connected at the same time. Sonar modules can be internal (built-in to your MFD) or external (a separate box on your network).



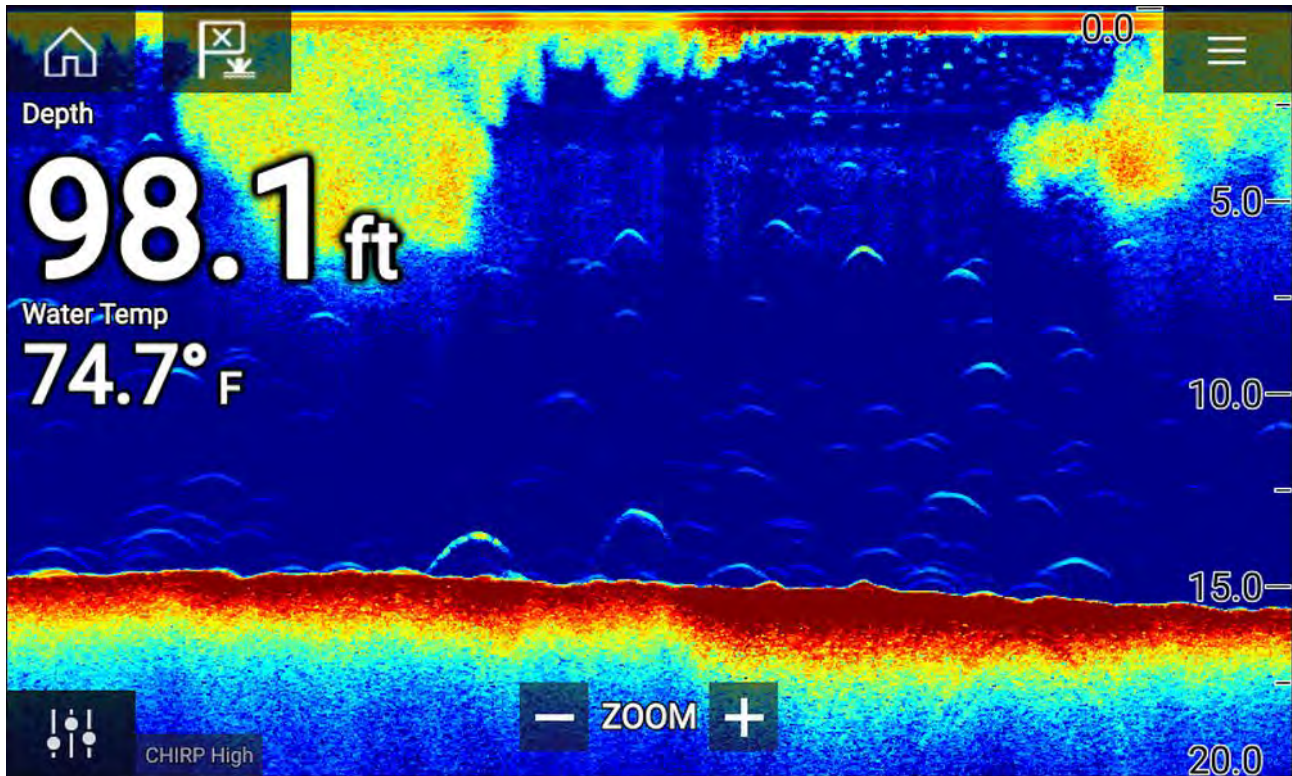

For each instance of the Fishfinder app you can select which Sonar module and channel that you want to use, the Sonar module and channel selection will persist over a power cycle.

The Fishfinder app can be displayed in both Fullscreen and splitscreen app pages. App pages may consist of up to 4 instances of the Fishfinder app.

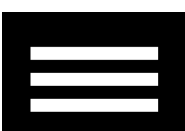

Fishfinder app controls

Icon	Description	Action
	Home icon	Takes you to the Homescreen
	Waypoint / MOB	Place waypoint / activate Man overboard (MOB) alarm
	Pilot icon	Opens and closes the Pilot Sidebar
	Menu icon	Opens the app menu

Icon	Description	Action
	Image adjustment	Displays onscreen sensitivity / image adjustment controls
	Pause	Pause RealVision™ 3D sonar image.
	Unpause	When the Fishfinder app is paused, you can recommence scrolling by selecting the Unpause icon.
	Range/Zoom In	When Auto range is enabled, pressing the plus icon activates Zoom mode, subsequent presses will increase the Zoom factor. When Range is set to Manual pressing the Plus icon decreases the distance displayed onscreen. Auto range can be enabled and disabled from the Menu: Menu > Auto range.
	Range/Zoom Out	When in Zoom mode, pressing the minus icon will decrease the Zoom factor and finally revert to normal mode. When Range is set to Manual pressing the Minus icon increases the distance displayed onscreen.

Touchscreen controls

- Pinch-to-zoom changes the magnification of the image.
- The Range control determines how far the sonar will ping.
- Press and hold onscreen to display the context menu

RealVision 3D controls

When using RealVision 3D sonar you can manipulate the view using touch gestures.

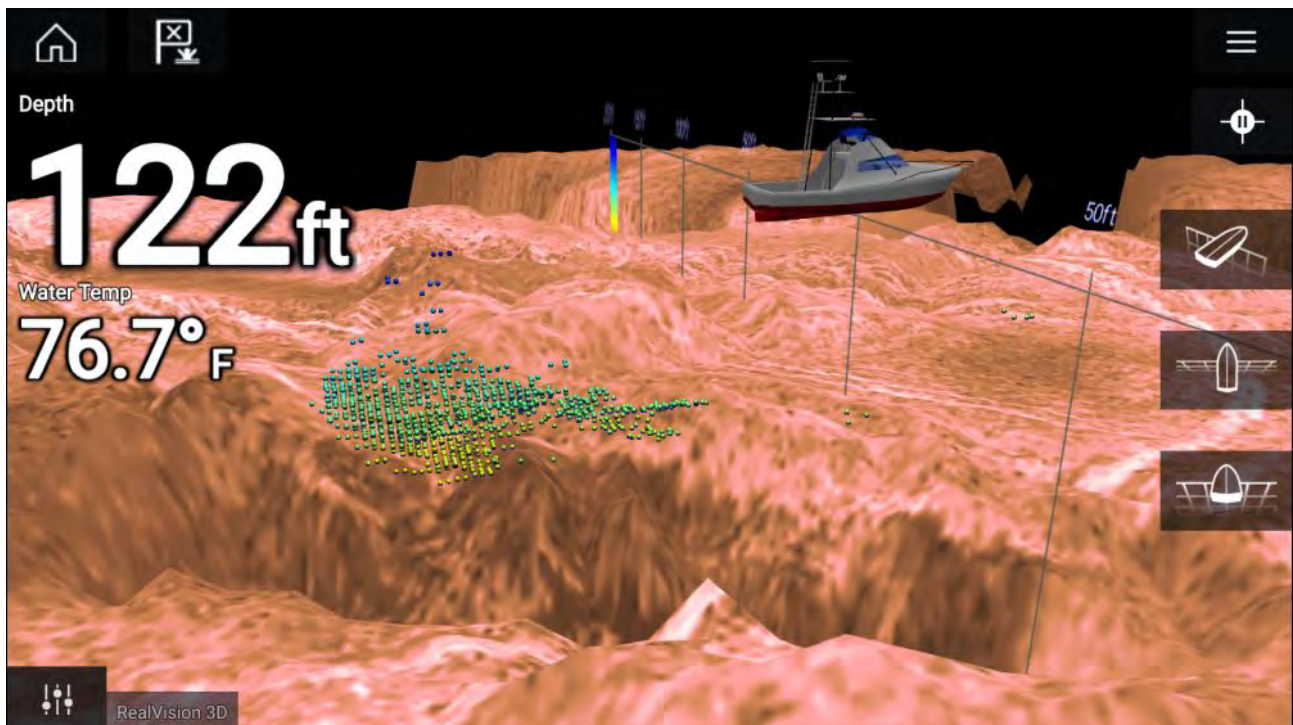

Touchscreen controls

- One finger swipe rotates the image.
- Two finger swipe pans the image around the screen.
- Pinch-to-zoom changes the magnification of the image.
- The Range control determines how far the sonar will ping.
- Press and hold onscreen to display the context menu

Physical buttons

- **Ok** button pauses Sonar scrolling.
- **Back** button resumes Sonar scrolling.
- **Ok** button when paused opens the context menu.
- Use the Uni-controller's **Directional** (Up, Down, Left, Right) controls to rotate the image.
- Use the Uni-controller's **Rotary** control or a RMK's **Range In** and **Range Out** buttons to Range in and out.

11.2 Opening the Fishfinder app

The Fishfinder app is opened by selecting a page icon from the Homescreen that includes a Fishfinder app.

Pre-requisites:

1. Ensure your Sonar module is compatible (check the latest details available on the Raymarine website). If in doubt contact an authorized Raymarine dealer for advice.
2. Ensure you have installed your Sonar module in accordance with the documentation that was supplied with the module.

The Fishfinder app will open in 1 of 4 states:

Please select a sonar channel

The first time you open a new app page that includes the Fishfinder app you will need to select a Sonar channel.

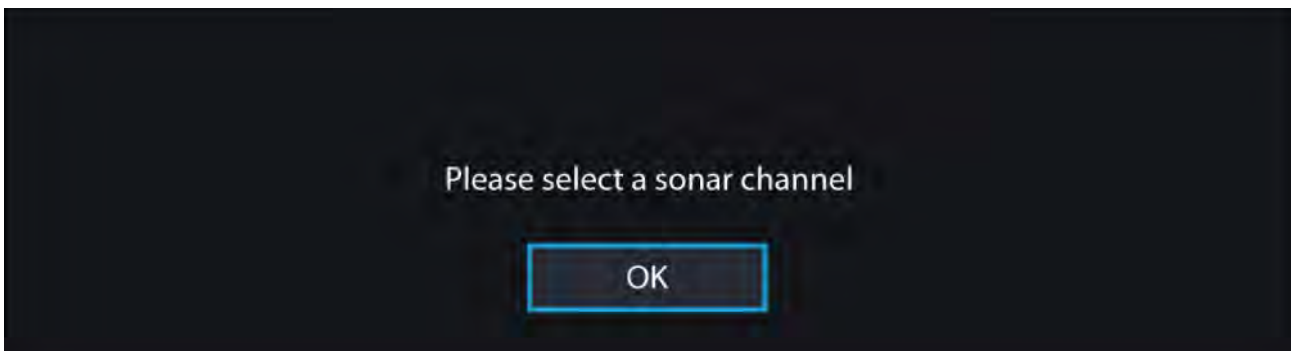

Select **OK** and then choose the Sonar channel you want to use from the list:

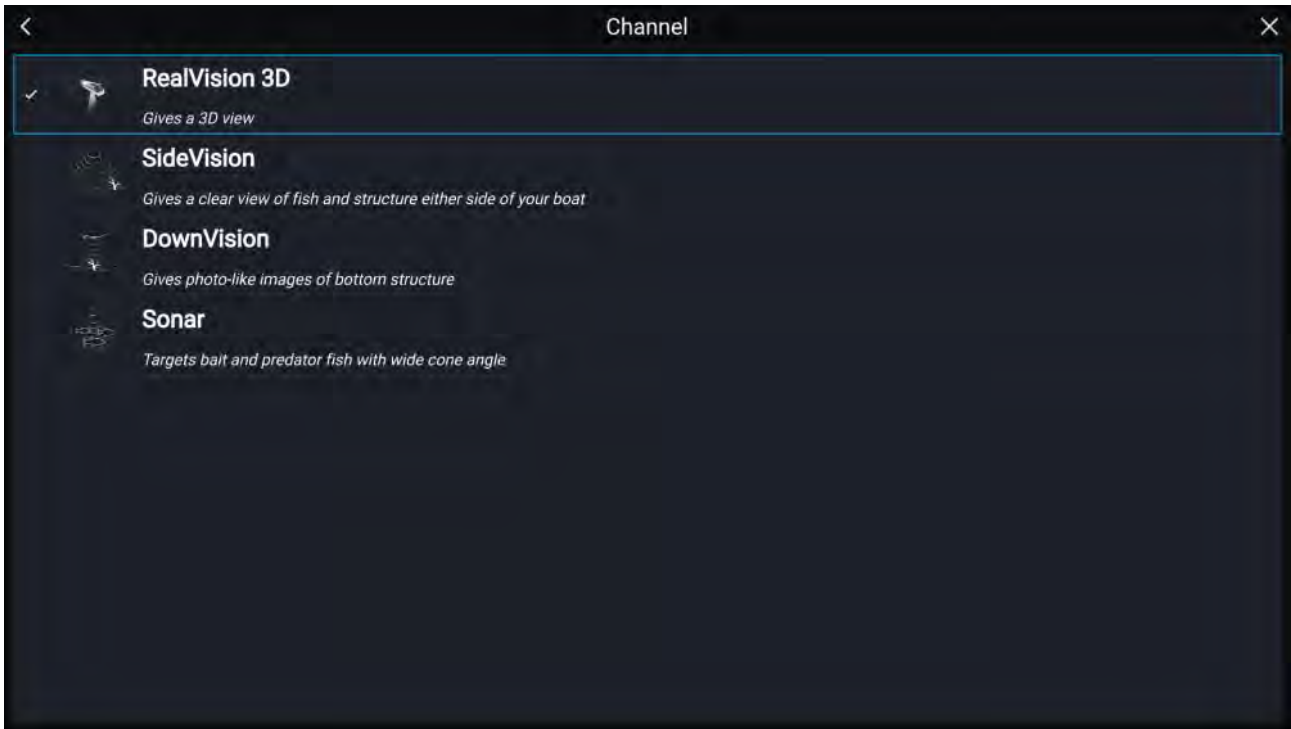

Sonar on and pinging

If your Fishfinder app has already been set up then when the Fishfinder app is opened the Sonar image will be displayed and start scrolling.

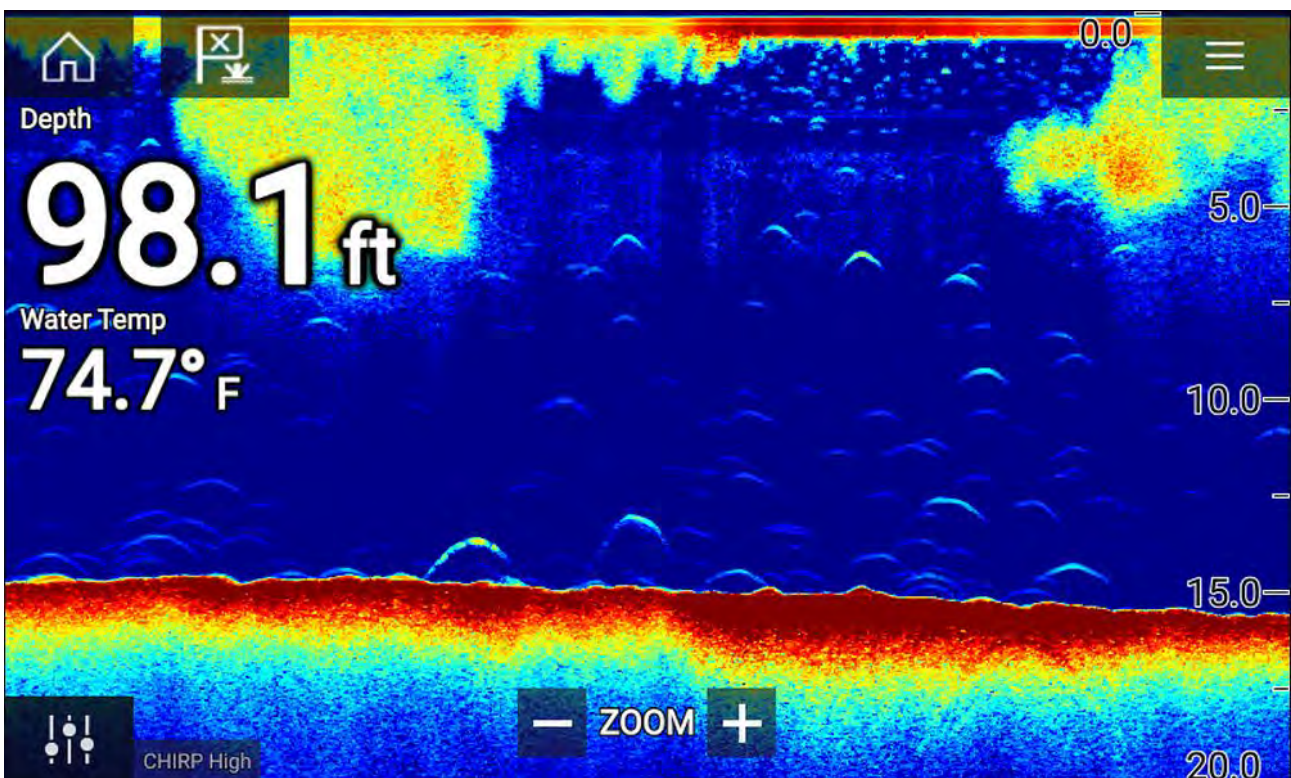

No sonar source available

If the 'No sonar source available' warning is displayed then either:

- your sonar module is still powering up.
- your MFD cannot establish a connection with your external Sonar module
- your Internal Sonar module has no transducer connected.

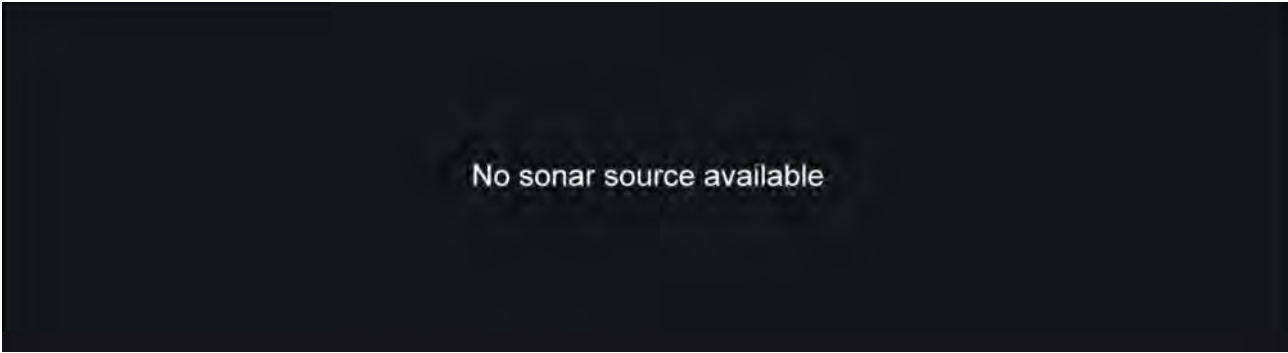

Check your external sonar module's network and power connection, check your MFD's network or transducer connection ensuring the connections and cabling is correct and free from damage, then power cycle your system. If the Sonar module is still not found then refer to your equipment's installation documentation for further troubleshooting information.

No transducer connected

If the '**No transducer connected**' warning is displayed then your Sonar module cannot connect to your transducer.

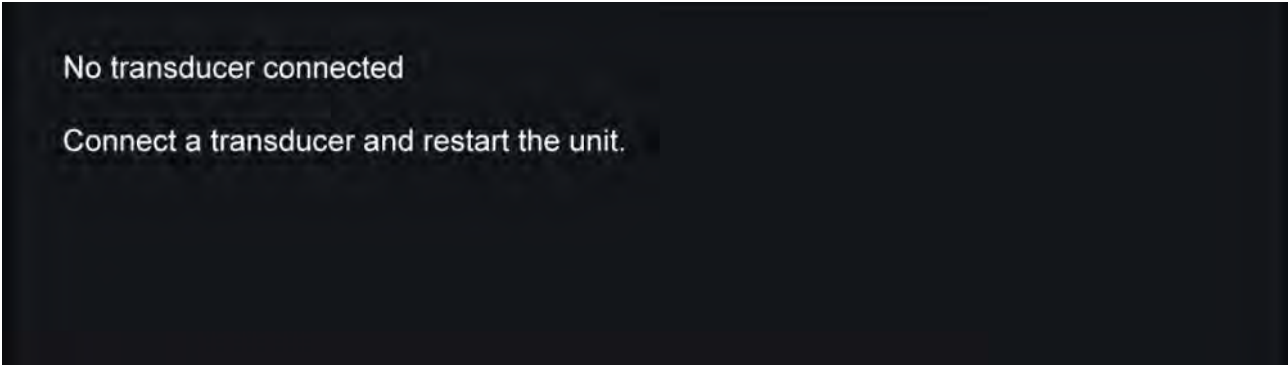

Check your transducer connection(s) are correct and free from damage, then power cycle your system. If the transducer is still not found then refer to your equipment's installation documentation for further troubleshooting information.

11.3 Sonar channels

The Sonar channels that are available depend on the Sonar module and transducer you have connected.



RealVision™ 3D



SideVision™

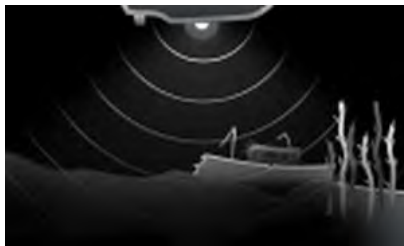

DownVision™



High CHIRP / High Frequency



Medium CHIRP / Medium Frequency



Low CHIRP / Low Frequency

Selecting a Sonar channel

The first time you open a new Fishfinder app page you will be requested to select a channel, subsequently you can change the sonar channel by selecting a channel icon from the Fishfinder app menu.

1. Select a relevant channel icon from the Menu.
2. Alternatively select **All channels** from the Menu and then choose your desired sonar module and channel.

11.4 Placing a Waypoint (Sonar, DownVision and SideVision)

When you observe something of interest in the Fishfinder app you can place a waypoint at its location so that you can find the area again.

1. Select and hold on the point of interest onscreen.
The Context menu is displayed and scrolling is paused, temporarily.
2. Select **Add Waypoint** from the context menu.

The Sonar image will remain paused for approximately 10 seconds after the Waypoint has been placed.

Placing a waypoint RealVision 3D

To place a waypoint whilst viewing a RealVision 3D channel follow the steps below.

1. Select and hold a location onscreen.
The Waypoint context menu and Red waypoint marker is displayed:

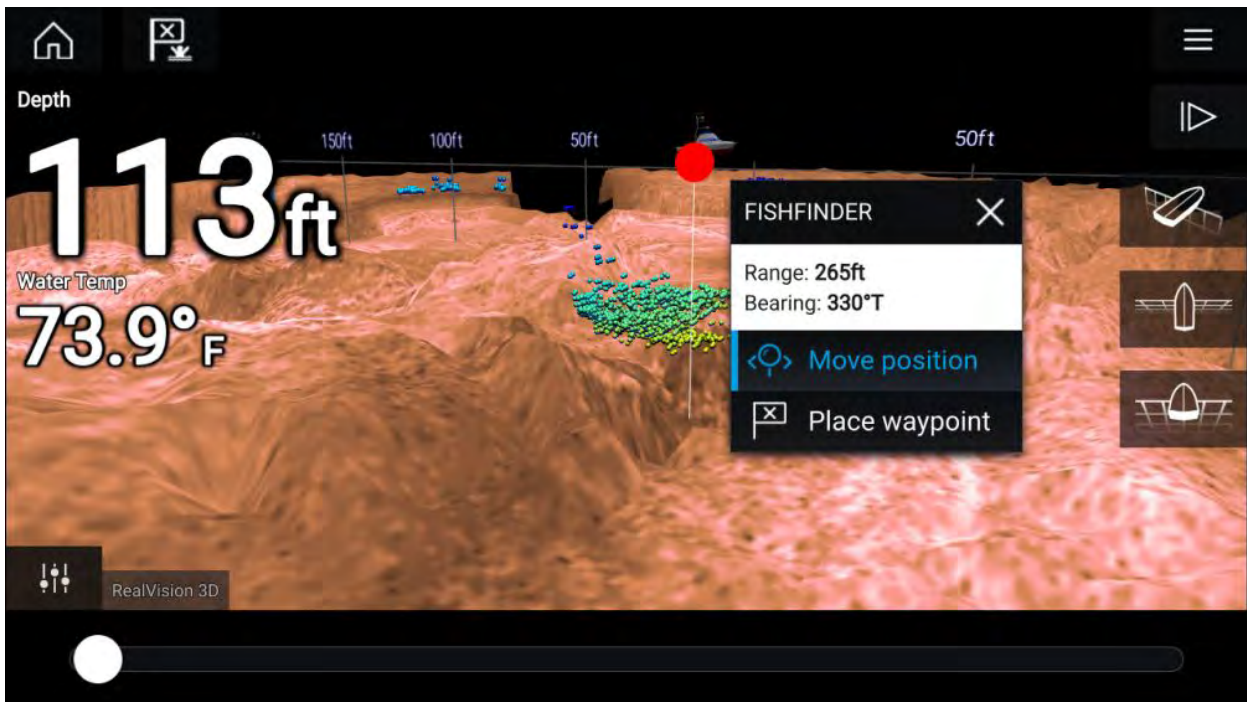

2. Select **Place waypoint** to create a waypoint at the marker's location, or

3. Select **Move position** to adjust the marker's position before creating the waypoint.

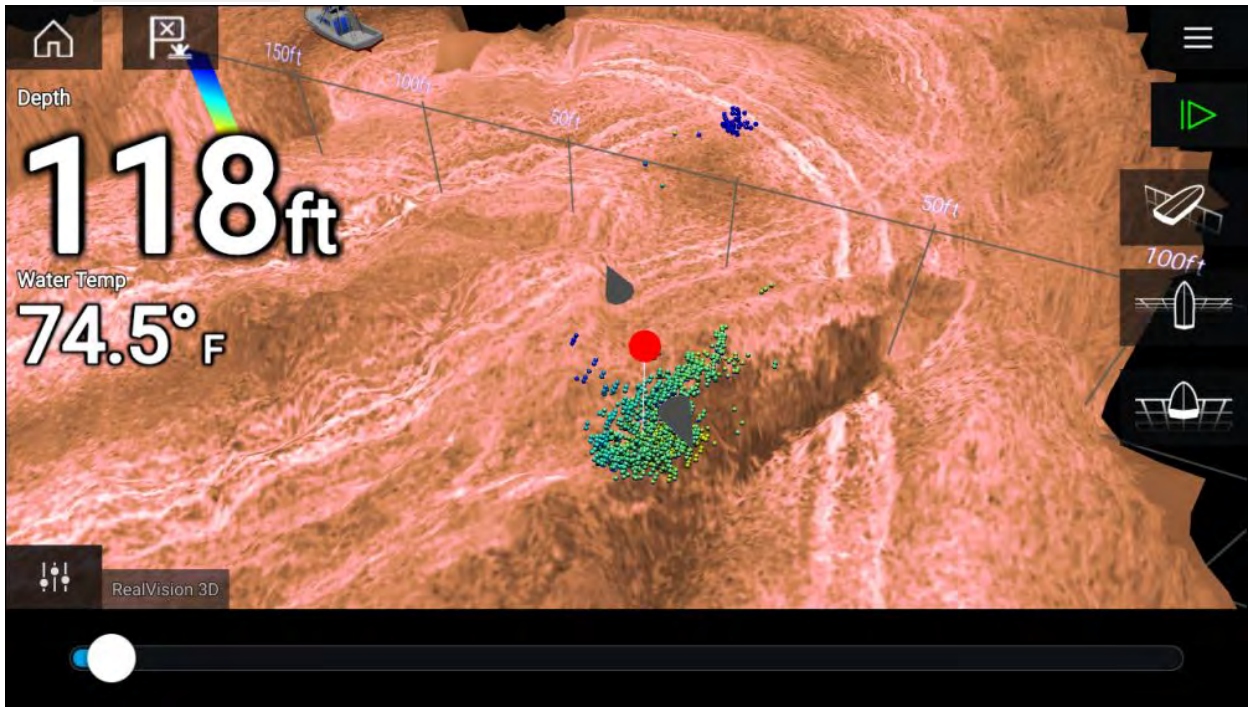

You can move the waypoint along its current axis by sliding 1 finger across the screen. You can also adjust the view onscreen using the usual 2 finger touch gestures.

4. When the marker is over the desired location select **Place waypoint** to save a waypoint at the marker's location.

11.5 Sonar scroll back

You can “scroll back” in the Fishfinder app to view sonar history.

To activate sonar “scroll back”, perform the following:

- **Sonar and DownVision** — Swipe your finger left to right across the sonar screen.
- **SideVision** — Swipe your finger from the bottom to the top of the sonar screen.
- **RealVision 3D** — Select the onscreen **Pause** icon.

When sonar scroll back is active the sonar **Scroll back bar** and **Unpause** icons are displayed.

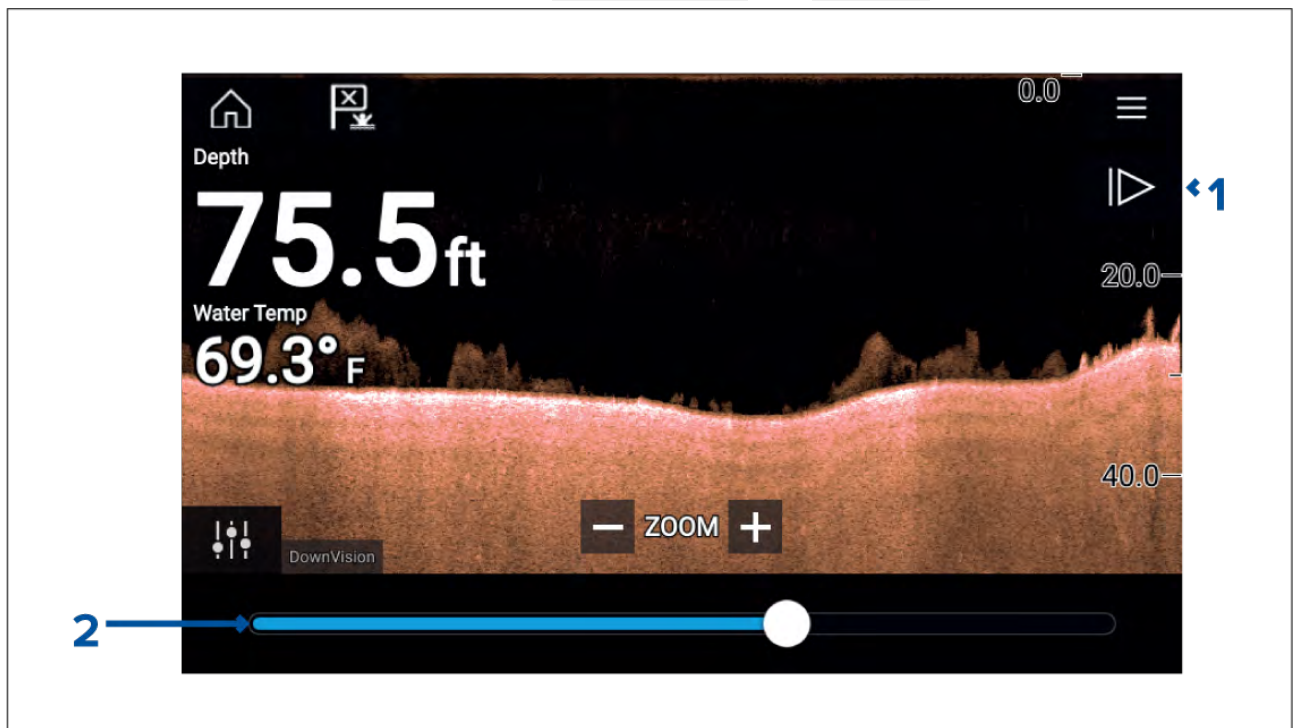

1. **Unpause** — Selecting this option resumes live sonar scrolling.
2. **Scroll back bar** — Use this to move back and forward through the available sonar history. You can either drag the position indicator right or left or select a specific location on the bar to jump to that position.

In Sonar, DownVision and SideVision channels, subsequent swipes will rewind the sonar history and swiping in the opposite direction will fast forward the sonar history.



11.6 Sonar sensitivity controls



Optimum performance is usually achieved using the default settings. You can adjust the image using the Sensitivity controls to improve the displayed image. Sensitivity setting adjustment is also applied to the sonar history that is displayed when using sonar scroll back.



Sensitivity settings can be accessed using the onscreen **Image adjustment** icon, or the Adjust sensitivity menu option: **Menu > Adjust sensitivity**.

The Sensitivity controls available are dependant upon the Sonar module in use.

Control	Name	Description
	'G' Gain	The control determines the signal strength at which target returns are shown onscreen. The Gain control can be set to Auto or Manual . Depending on Sonar module, in Auto you can add an offset of up to $\pm 50\%$. A higher value produces more target returns and noise onscreen.
	'I' Intensity, or 'CG' Color Gain	The control sets the lower limit for the color used for the strongest target returns. All target returns above this value are displayed in the strongest color. Those with a weaker value are divided equally between the remaining colors. The control can be set to Auto or Manual . Depending on Sonar module, in Auto you can add an offset of up to $\pm 50\%$.
	'SF' Surface Filter , or 'NF' Noise filter	The control determines the amount of noise displayed onscreen by varying the gain throughout the water column. A lower value decreases the depth at which the control is applied. The control can be set to Auto or Manual .

Control	Name	Description
	'TVG' Time Varied Gain	The control determines the amount of attenuation applied throughout the water column to ensure that targets of a similar size appear the same regardless of depth. A higher value produces weaker targets and less noise onscreen. The control can be set to 1 of 3 Auto modes or can be set to Manual .
	All to Auto	Sets all Sensitivity settings to Auto with 0% offset.

11.7 Fishfinder settings menu

The table below lists settings applicable to the Fishfinder app and their location within the app Settings menu. The settings available are dependant upon the Sonar module in use.

Sonar display tab

Settings	Description	Options
Color palette	Various color palettes are available to suit different conditions or your personal preference.	List of color palettes.
View selection buttons	Enables and disables SideVision™ Left, Right and Both onscreen channel selection icons.	<ul style="list-style-type: none"> • On • Off
A-scope	A-Scope mode provides a splitscreen view that includes the normal scrolling sonar image and a smaller pane which shows a 'live' image of what is directly below your transducer.	<ul style="list-style-type: none"> • Off • Center • Right • Cone
Bottom lock	Bottom lock flips the range indication so that the bottom always appears flat.	<ul style="list-style-type: none"> • On • Off
Range lines	Displays vertical range lines when viewing.	<ul style="list-style-type: none"> • On • Off
Depth lines	Displays horizontal depth lines.	<ul style="list-style-type: none"> • On • Off
White line	Displays a solid white line along the bottom contour.	<ul style="list-style-type: none"> • On • Off
Bottom fill	Displays a solid color fill for the bottom.	<ul style="list-style-type: none"> • On • Off
Color threshold	Color threshold determines the signal strength below which target returns are not shown. A low value results in only the strongest colors or lightest shades being displayed.	• 0% to 100%
Scroll speed	Determines the scrolling speed for the Sonar image.	• 10% to 500%

RealVision™ 3D — Sonar display tab

Settings	Description	Options
Boat icon	Choose which boat icon to use.	List of available Boat icons.
Image stabilization	Uses RealVision™ 3D transducer's built-in sensors to counter-act the rocking motion of your vessel to produce a stable sonar image.	<ul style="list-style-type: none"> • On • Off
Target colors	Changes the color palette used for target returns.	List of color palettes.
Color targets by	Changes the way targets are colored. Depth colors targets according to their depth, a gradient scale can be shown on the 3D grid to aid depth identification. Intensity colors targets according to their size, the bigger the target the darker the color used.	<ul style="list-style-type: none"> • Depth • Intensity
Show targets as	Changes the method of rendering targets, Point provides the highest resolution, Sphere provides a lower resolution but increases target size for increased visibility.	<ul style="list-style-type: none"> • Point • Sphere
Bottom colors	Changes the color used for bottom structure.	List of colors.
Background	Changes the color used for the app background.	List of colors.
View mode	In GPS track mode the boat icon will remain in the same position and bottom structure and target detail will move in true relation to your vessel movements. In Scrolling image mode the sonar pings at a constant speed and displays a scrolling image behind the boat icon.	<ul style="list-style-type: none"> • GPS track • Scrolling image

Transducer tab

Settings	Description	Options
Transducer	Allows selection of Sonar transducer.	List of available transducers.
Display depth as	Determines the position from where depth readings are taken from.	<ul style="list-style-type: none"> • Below keel • Below waterline • Below transducer
Speed transducer	Allows selection of Speed transducer.	List of available transducers.
Calibrate speed	Allows you to enter an offset between actual measured speed and the current speed displayed by your transducer.	Offset value.
Enable temperature sensor	Enables and disables the selected transducer's temperature sensor.	<ul style="list-style-type: none"> • On • Off
Calibrate temp	Allows you to enter an offset between actual measured water temperature and the current temperature displayed by your transducer.	Offset value.

Sounder tab

Settings	Description	Options
Sounder name	Allows you to rename your sonar module.	Onscreen keyboard.
Ping enable	Enables and disables transducer ping.	<ul style="list-style-type: none"> • On • Off

Settings	Description	Options
Ping rate limit	Allows you to restrict the transducer's maximum ping rate to suit current conditions.	<ul style="list-style-type: none"> • 1 to 100
Power mode	Adjusts the transducer's signal strength. In Auto the sonar module will automatically determine the optimal power based on current depth, speed and bottom signal. In Manual you can adjust the power to the desired level.	<ul style="list-style-type: none"> • 1 to 100
Ping rate	Hyper ping should be used at speeds of up to 40 knots in shallower waters (6 metres or less). When the depth reaches 6 metres or above the ping rate will automatically reduce to normal until depth conditions are met.	<ul style="list-style-type: none"> • Normal • Hyper
Dual channel ping mode	On sonar modules that offer simultaneous dual channel operation, such as the CP570, The ping mode can be changed. Auto the Fishfinder app will select the best mode chosen based on range settings. Independent pings maximizes ping rate but may introduce interference. Simultaneous pings reduced ping rate and reduces chance of interference.	<ul style="list-style-type: none"> • Auto • Independent pings • Simultaneous pings
Tune frequency	Enables manual tuning of non-CHIRP frequency channels.	<ul style="list-style-type: none"> • -50% to +50%
AHRS stabilization	The AHRS built in to the RealVision™ 3D transducer is used to stabilize the sonar image onscreen based on your vessel's detected movements.	<ul style="list-style-type: none"> • On • Off
Reverse Port/Starboard	When a RV100 transducer is hull/step mounted the transducer can be installed with the cable orientated towards either the bow or the stern of the vessel. On installations where the transducer cable is orientated towards the stern of the vessel then the Reverse Port/Starboard control must be enabled.	<ul style="list-style-type: none"> • Enabled • Disabled
Interference rejection	Removes interference caused by other transducers on your vessel or from vessels equipped with transducers close by.	<ul style="list-style-type: none"> • Auto • Low • Medium • High • Off
2nd echo rejection	The control helps to remove false target returns or false bottom that can be caused by signal reflection.	<ul style="list-style-type: none"> • Off • Low • High
Reset sounder	Resets the sonar module to factory default settings.	<ul style="list-style-type: none"> • Yes • No
Reset trip	In installations that include a speed transducer connected via the sonar module a trip log is automatically recorded. Selecting this option resets the sonar module's trip log.	<ul style="list-style-type: none"> • Yes • No

Note:

The fish detection tab is only available when viewing a high CHIRP sonar channel.

Fish detection tab

Menu item and description	Options
<p>Fish detection beep: Enables and disables audible beep when a target is detected that is considered to be a fish.</p>	<ul style="list-style-type: none"> • On • Off (default)
<p>Fish icons: Enables and disables display of a fish icon over targets considered to be fish.</p>	<ul style="list-style-type: none"> • On • Off (default)
<p>Fish depth labels: Enables and disables display of depth labels next to targets considered to be fish.</p>	<ul style="list-style-type: none"> • On • Off (default)
<p>Detection sensitivity: Determines how sensitive the fish detection algorithm is. The higher the value, the more target returns will be considered to be fish.</p>	Values from 0 to 100 (75 (default)).
<p>Ignore fish shallower than: Targets returns found in water shallower than the specified depth will not be considered to be fish.</p> <hr/> <p>Note: The shallow limit cannot be greater than the deep limit.</p>	0 ft to 1000 ft (3.3 ft (default)) or equivalent units.
<p>Ignore fish deeper than: Targets returns found in water deeper than the specified depth will not be considered to be fish.</p> <hr/> <p>Note: The deep limit cannot be less than the shallow limit.</p>	0 ft to 1000 ft (984 ft (default)) or equivalent units.

Page settings tab

Settings	Description
Data Overlays	Enables configuration of Data overlays, which overlay key information from connected sensors onto the Chart, Radar, Sonar and Camera apps.
Edit split ratio	Enables you to customize the position of the partitions in splitscreen app pages. For example, 50/50, 70/30 etc.

Chapter 12: Radar app

Chapter contents

- [12.1 Radar app overview on page 256](#)
- [12.2 Radar feature comparison on page 258](#)
- [12.3 Opening the Radar app on page 261](#)
- [12.4 Set up on page 263](#)
- [12.5 Radar modes on page 264](#)
- [12.6 Range and bearing on page 266](#)
- [12.7 AIS targets on page 268](#)
- [12.8 Radar targets on page 273](#)
- [12.9 Dangerous targets alarm on page 280](#)
- [12.10 Guard zone alarms on page 280](#)
- [12.11 Doppler Radar overview on page 282](#)
- [12.12 Blank sectors on page 283](#)
- [12.13 Radar sensitivity controls on page 284](#)
- [12.14 Radar settings on page 285](#)

12.1 Radar app overview

The Radar app displays a visualization of the echoes received from a connected Radar scanner. The Radar app is a navigation aid used to help enhance collision and situational awareness by enabling target's distance and speed to be tracked in relation to your vessel.

Up to 2 Radar scanners can be connected at the same time. However, only 1 Radar in a system can be a Quantum™ Radar.

For each instance of the Radar app you can select which Radar scanner you want to use, the Radar scanner selection will persist over a power cycle.

The Radar app can be displayed in both Fullscreen and splitscreen app pages. App pages may consist of up to 2 instances of the Radar app.

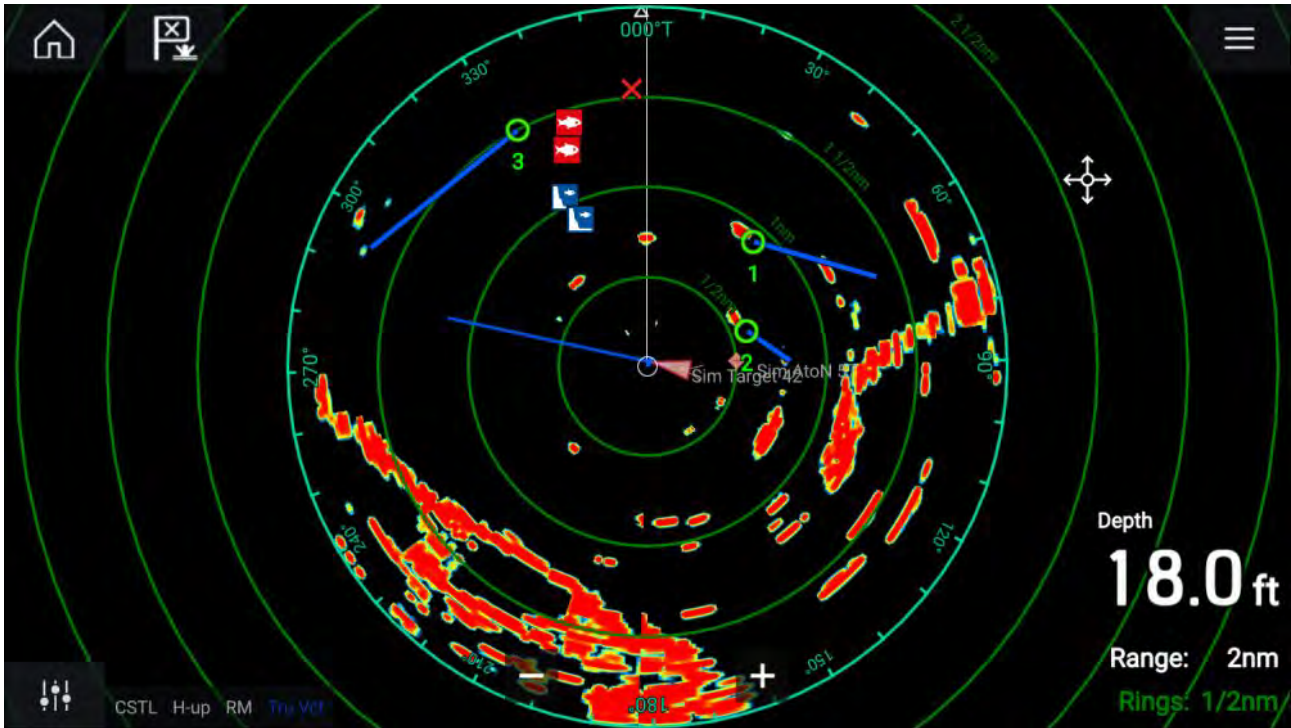









In the Radar app symbols are used to represent the location of Waypoints, Tracked Radar targets and AIS targets.

The Radar app allows you to configure alarms which are triggered when a target or object conflicts with the **Dangerous targets** or **Guard Zone** alarm settings.

The Range rings, bearing ring and VRM/EBLs can be used to identify a targets distance and heading in relation to your vessel.

Radar app controls

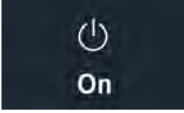
Icon	Description	Action
	Home icon	Takes you to the Homescreen
	Waypoint / MOB	Place waypoint / activate Man Overboard (MOB) alarm
	Pilot icon	Opens and closes the Pilot Sidebar

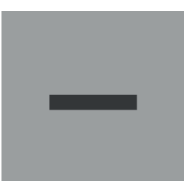
Icon	Description	Action
	Menu icon	Opens the App menu
	Image adjustment	Displays onscreen sensitivity / image adjustment controls
	Power Off	Powers down the current Radar scanner
	Power On	Powers up the selected Radar scanner
	Transmit	Start Radar transmission
	Range In	Decreases the distance displayed onscreen (minimum range: 1/16nm).
	Range Out	Increases the distance displayed onscreen (up to your Radar scanner's maximum range).

Radar app context menu

Context menus provide context sensitive menu options.



- Context menus are accessed in the Radar app by selecting a location or target.
- The context menu provides Latitude, longitude, range and bearing details for the selected location or object.
- The context menu provides quick access to relevant settings or features.
- Select **More options** to display further options.

Camera tracking

When connected to a compatible Pan and Tilt Thermal camera you can track targets or point your camera at a specific target or area.

2 options are available for camera tracking:

- **Point camera here** — Points the camera at a specific point onscreen, the camera will remain pointed at this area regardless of your own vessel's course.
- **Track with camera** — Tracks a selected target regardless of your own vessel's or target's course.

Camera tracking options are available from the Context menu in the Chart and Radar apps: **Context menu > more options > Point camera here**, or **Context menu > more options > Track with camera**.

Automatic tracking

You can use the Camera app settings to configure automatic tracking for AIS, Radar and MoB targets: **Camera app > Menu > Settings > Camera motion > AUTO TRACKING**

12.2 Radar feature comparison

The range of features and settings that are available in the Radar app is dependent on the type of connected Radar scanner.

Sensitivity controls

Features/settings	Radar type
Gain	• All
Color Gain	• Magnum Open Array • Quantum™ 2 Doppler • Quantum™ • SuperHD™ Open Array • HD Open Array • HD Radome
Rain	• All
Sea Clutter	• All
FTC (Fast Time Constant)	• Digital Radome
Power Boost	• Magnum Open Array • SuperHD™ Open Array
Antenna Boost	• Magnum Open Array • SuperHD™ Open Array

Gain Modes

Features/settings	Radar type
Buoy	• Magnum Open Array • SuperHD™ Open Array • HD Open Array • HD Radome
Harbor	• All
Coastal	• All
Offshore	• All

Features/settings	Radar type
Bird	<ul style="list-style-type: none"> • Magnum Open Array • SuperHD™ Open Array • HD Open Array • HD Radome
Weather	<ul style="list-style-type: none"> • Quantum™ 2 Doppler • Quantum™

Features

Features/settings	Radar type
Doppler	<ul style="list-style-type: none"> • Quantum™ 2 Doppler
Dual Range	<ul style="list-style-type: none"> • Magnum Open Array • SuperHD™ Open Array • HD Open Array • HD Radome
Interference Rejection	<ul style="list-style-type: none"> • All
Interference Rejection Level	<ul style="list-style-type: none"> • Quantum™ 2 Doppler • Quantum™ • Digital Radome
Target Expansion	<ul style="list-style-type: none"> • All
Expansion Level	<ul style="list-style-type: none"> • Digital Radome
Guard Zones	<ul style="list-style-type: none"> • All = 2
Guard Zone Sensitivity	<ul style="list-style-type: none"> • All
Radar Targets	<ul style="list-style-type: none"> • Magnum Open Array = 25 • Quantum™ 2 Doppler = 25 • Quantum™ = 10 • SuperHD™ Open Array = 25 • HD Open Array = 25 • HD Radome = 25 • Digital Radome = 10
Auto acquire (targets)	<ul style="list-style-type: none"> • Magnum Open Array = 25 • Quantum™ 2 Doppler = 25
Tuning	<ul style="list-style-type: none"> • Magnum Open Array • SuperHD™ Open Array • HD Open Array • HD Radome
Transmit Frequency	<ul style="list-style-type: none"> • Quantum™ 2 Doppler • Quantum™

Features/settings	Radar type
Scanner Rotation Speed	<ul style="list-style-type: none"> • Magnum Open Array = 24 RPM / Auto (48 RPM) • Quantum™ 2 Doppler = 24 RPM • Quantum™ = 24 RPM • SuperHD™ Open Array = 24 RPM / Auto (48 RPM) • HD Open Array = 24 RPM / Auto (48 RPM) • HD Radome = 24 RPM / Auto (48 RPM) • Digital Radome = 24 RPM
Sea Clutter Curve	<ul style="list-style-type: none"> • All
Parking Offset	<ul style="list-style-type: none"> • Magnum Open Array • SuperHD™ Open Array • HD Open Array
Antenna Size selection	<ul style="list-style-type: none"> • Magnum Open Array • SuperHD™ Open Array = 4ft / 6ft • HD Open Array = 4ft / 6ft
Timed Transmit	<ul style="list-style-type: none"> • All
Bearing Alignment	<ul style="list-style-type: none"> • All
MBS (Main Bang Suppression) Off	<ul style="list-style-type: none"> • All
Tuning Preset	<ul style="list-style-type: none"> • Magnum Open Array • SuperHD™ Open Array • HD Open Array • HD Radome • Digital Radome
STC (Sensitivity Time Control) Preset	<ul style="list-style-type: none"> • Digital Radome
VRM/EBL (Variable Range Markers/Electronic Bearing Line)	<ul style="list-style-type: none"> • All
Display Timing	<ul style="list-style-type: none"> • SuperHD™ Open Array = 0–767m • HD Open Array = 0–767m • HD Radome = 0–767m • Digital Radome = 0–153.6m
Max Range	<ul style="list-style-type: none"> • Magnum Open Array = 4kW = 72nm, 6kW = 96nm • Quantum™ 2 Doppler = 24nm • Quantum™ = 24nm • SuperHD™ Open Array = 72nm • HD Open Array = 72nm • HD Radome = 48nm • Digital Radome = 48nm
Colors	<ul style="list-style-type: none"> • Magnum Open Array = 256 • Quantum™ 2 Doppler = 256 • Quantum™ = 256 • SuperHD™ Open Array = 256 • HD Open Array = 256 • HD Radome = 256 • Digital Radome = 8

Compatible Radar scanners

- Magnum Open Array.
- Quantum™ 2 Doppler.
- Quantum™.
- SuperHD™ Open Array.
- HD Open Array.
- HD Radome.
- Digital Radome.

12.3 Opening the Radar app

The Radar app is opened by selecting a page icon from the Homescreen that includes the Radar app.

Pre-requisites:

1. Ensure your Radar scanner is compatible, check the latest details available on the Raymarine website, if in doubt please contact an authorized Raymarine dealer for advice.
2. Ensure you have installed your Radar scanner in accordance with the documentation that was supplied with your Radar.

The Radar app will open in 1 of 3 states:

Off/Not Connected

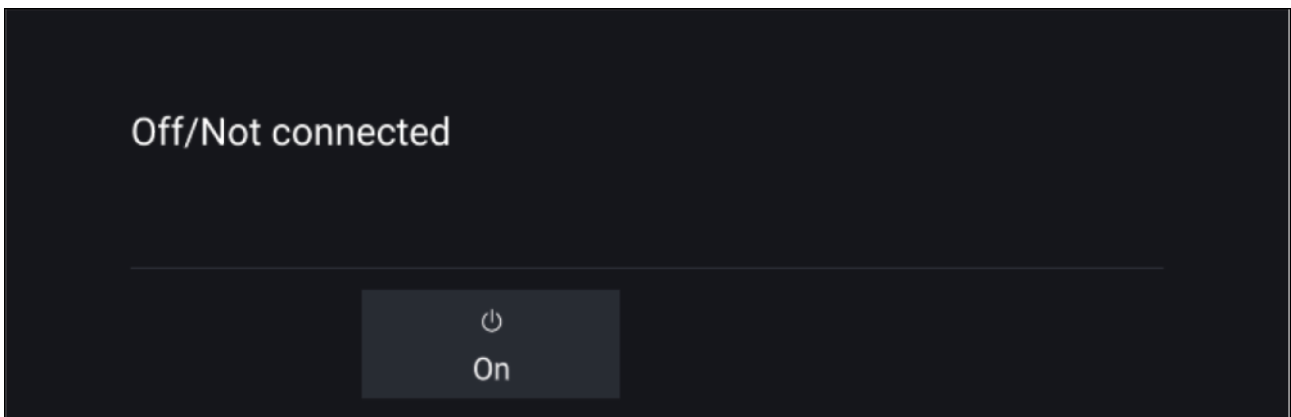

If the '**Off/Not Connected**' message is displayed then:

- your Radar scanner may be powered down, or
- your MFD cannot establish a connection with your Radar scanner

Select **On** to power up your Radar. If the '**Radar not found**' message is displayed then a connection could not be established, ensure that network and power connections to your Radar and MFD are correct and free from damage and then power cycle your system. If the Radar scanner can still not be found refer to your Radar's installation documentation for further troubleshooting information.

Off

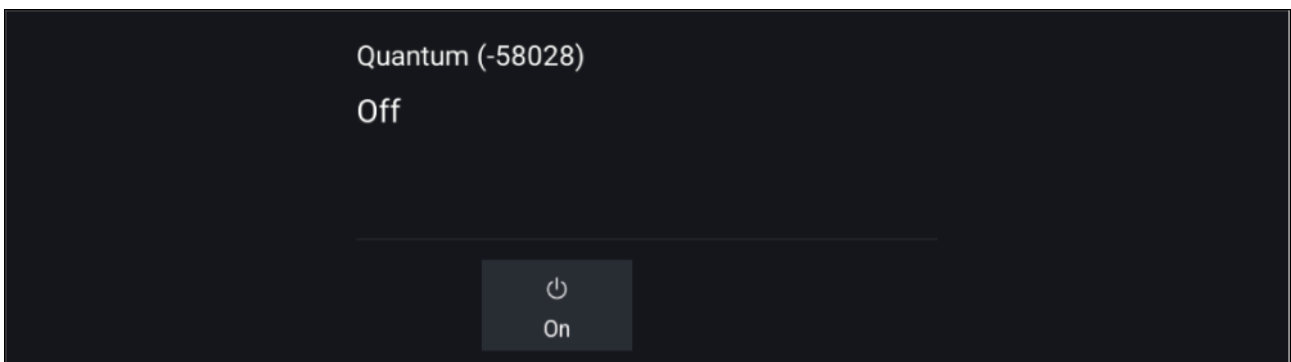

If the '**Off**' message is displayed then your Wi-Fi connected Radar scanner is paired but powered off, select **On** to power up your Radar

Standby (Not transmitting)

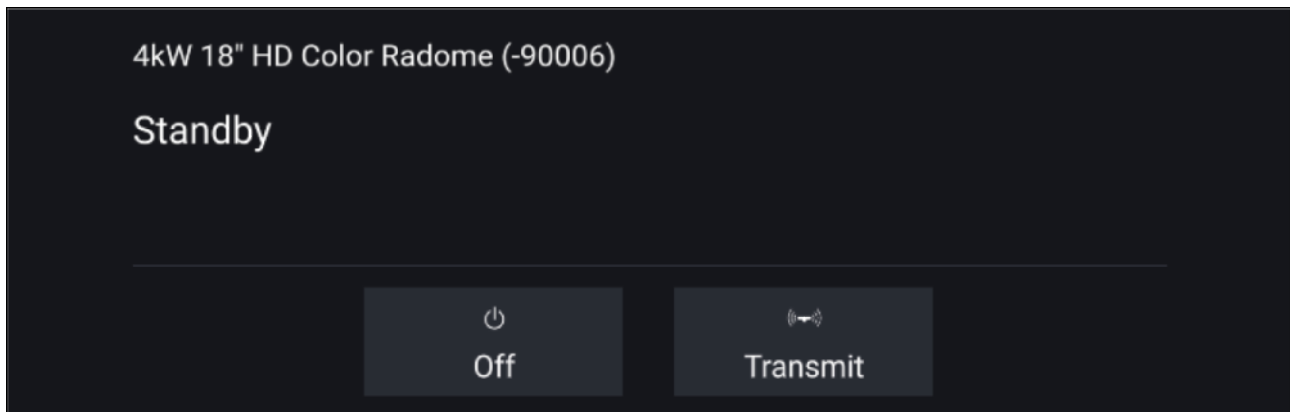

If the 'Standby' message is displayed then select **Transmit** to begin transmitting.

Transmitting

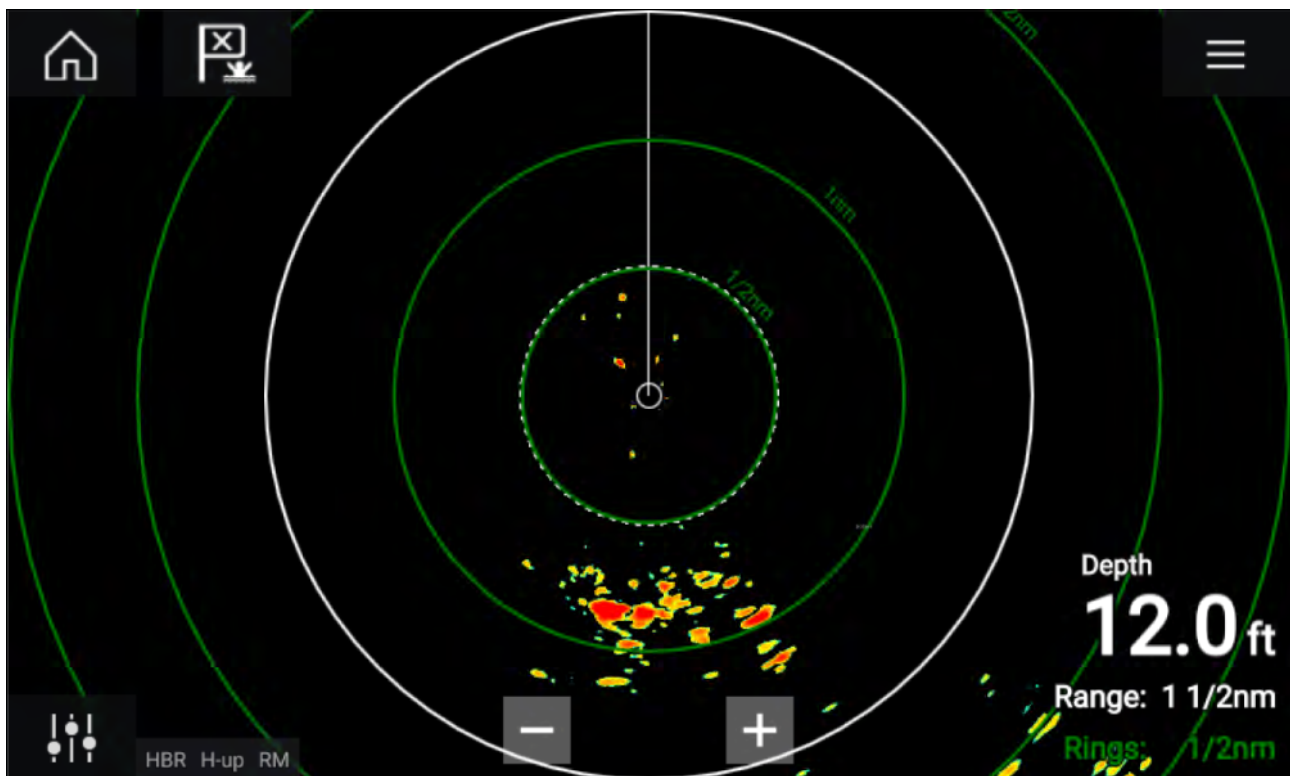

If your Radar scanner is connected, powered up and transmitting then the Radar image is displayed and echoes/targets are displayed onscreen.

Putting the radar into standby

With your selected radar displayed onscreen:

1. Select **Transmit** from the main menu.
The radar scanner will stop transmitting and is put into standby mode.

Powering down your radar scanner

With your radar scanner in standby mode:

1. Select the **Off** icon.
2. Select **Yes** to confirm power down.

The radar scanner will still consume a small amount of power whilst it is powered off, this is to ensure the radar can be powered back up quickly.

12.4 Set up

Selecting a Radar scanner

On systems with 2 Radar scanners, you can select which Radar scanner is used in each instance of the Radar app.

1. Select the **Settings** icon from the Radar app menu.

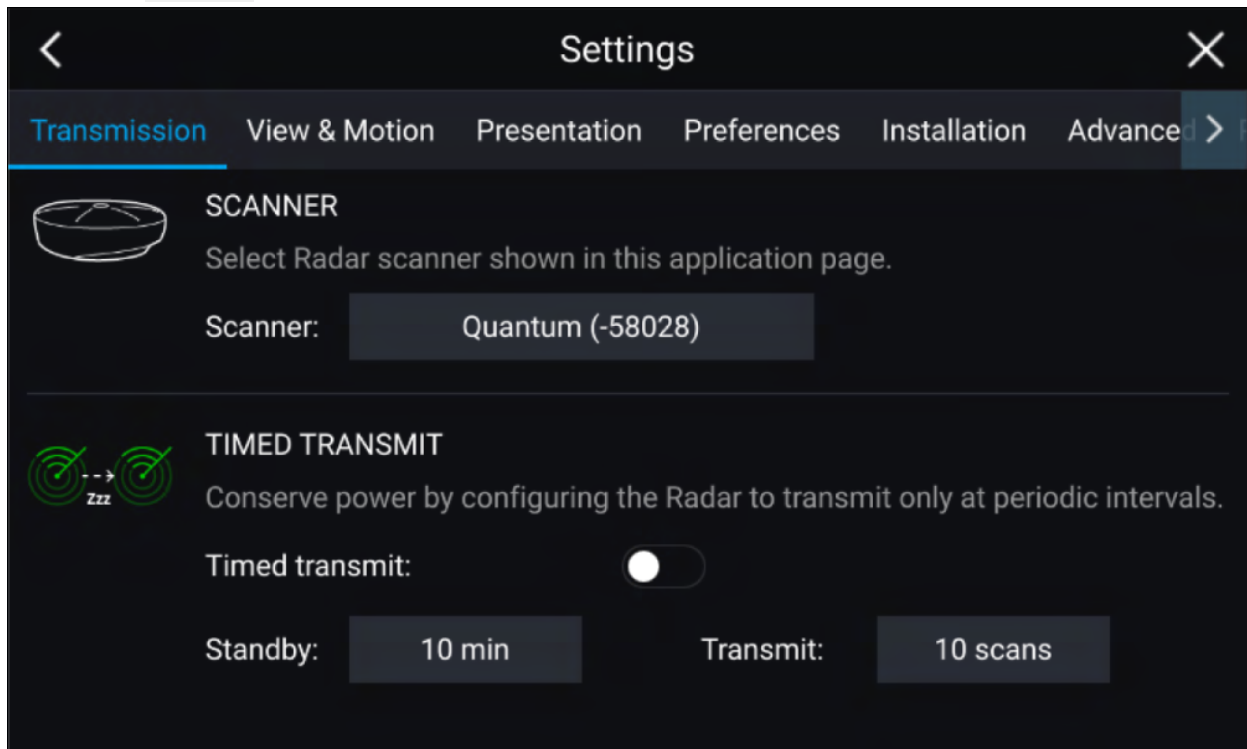

2. Select the **Scanner:** box on the **Transmission** tab.
A list of available Radar scanners is displayed.
3. Select the Radar scanner that you want to associate with the current instance of the Radar app.
4. Close the **Settings** page.

The current instance of the Radar app will change to display the selected Radar scanner. Radar scanner selection shall persist over a power cycle.

Alternatively, with the Radar powered off or in Standby, you can select switch Radar scanner by selecting **Change scanner**.

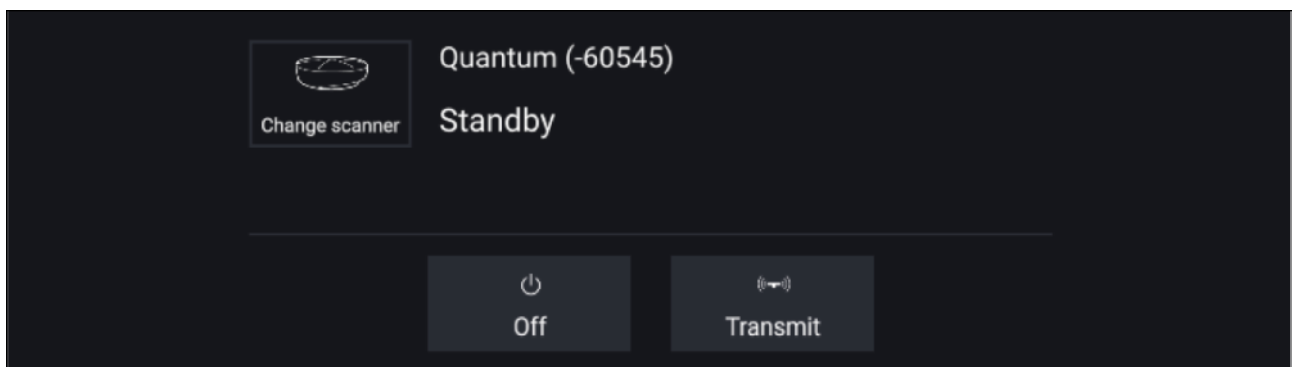

Dual range

HD and SuperHD Radar scanners are capable of **Dual range**. Dual range enables you to view 2 ranges (i.e. Short range and Long range) simultaneously.

To view both ranges you will need to configure a splitscreen, dual Radar, app page that displays the same Radar scanner in each window. You can then enable **Dual Range** mode and set the **Channel** for each window from the **Transmission** tab: **Menu > Settings > Transmission**.

Dual range limitations:

- Dual range cannot be enabled when Radar targets are being tracked (clear the target list and try again).
- When Dual range is enabled Radar target tracking is disabled.
- When Dual range is enabled Automatic Radar target acquisition is disabled.
- In Dual range the maximum rotation speed is 24rpm.
- When using a SuperHD Radar **Antenna boost** and **Power boost** controls are only applied to the Long range channel. Open Array Radar scanners running version 1.xx or 2.xx software will have the Short range channel's maximum range restricted to 3 nm.
- When Dual range is enabled on a Radar scanner running version 1.xx or 2.xx software the **Expansion** control will be disabled.

Timed Radar transmission

To help conserve power you can configure your Radar to only transmit periodically.

From the Radar menu:

1. Select the **Settings** icon.
The settings page is displayed.
2. Switch on **Time Transmit**: using the toggle switch.
3. Select **Standby**: and choose a time interval.
4. Select **Transmit**: and choose the number of rotations you want the Radar to perform.

The Radar will transmit for the specified number of rotations and then will switch to Standby for the specified time interval, the sequence will repeat until Timed Transmit is switched off.

The Timed transmit will revert to Off after a power cycle.

Setting open array antenna size

When connected to an Open Array Radar Scanner you can configure the **Antenna size**. Setting the antenna size can help when setting a **Parking offset**.

From the Radar app:

1. Select **Menu > Settings > Transmission**.
2. Select the correct size for your Radar's antenna from the **Antenna size** option.

Bearing alignment

The Radar bearing alignment ensures that Radar objects appear at the correct bearing relative to your vessel's bow. You should check the bearing alignment for any new installation.

Checking alignment

Align the bow with a stationary object between 0.25 and 2 NM away.

Reduce the gain to make the target as small as possible on the screen.

Note the position of the object on the Radar screen. If the target is not under the ship's heading marker (SHM), then bearing alignment adjustment is required.

Adjusting alignment

Adjust the **Bearing alignment** setting until the target object appears under the SHM.

Bearing alignment setting can be accessed from the **Installation** tab: **Menu > Installation > Bearing alignment**.

Note: Heading (HDG) is displayed in the Radar application. Please be aware that bearing alignment refers to the **relative** bearing of **targets** to the vessel's bow using visual checks / traditional means.

12.5 Radar modes

The Radar app provides preset modes that can be used to quickly achieve the best picture depending on your current situation. Only Radar modes supported by your Radar scanner are shown.

To change Radar mode select the required mode from the Radar app menu.



HARBOR

Harbor mode takes into account land clutter that is typically encountered in a Harbor, so that smaller targets are still visible. This mode is useful when navigating in a Harbor.

Radar scanners: All.



BUOY

Buoy mode enhances the detection of smaller targets such as mooring buoys, and is useful at ranges up to 3/4nm.

Radar scanners: SuperHD™ Open Array, HD Open Array and HD Radome.



COASTAL

Coastal mode takes into account slightly higher levels of Sea clutter that are encountered out of Harbor areas. This mode is useful when in open water but keeping to coastal areas.

Radar scanners: All.



OFFSHORE

Offshore mode takes into account high levels of Sea clutter so that targets are still visible, useful when navigating in open water away from the coast.

Radar scanners: All.



BIRD

Bird mode optimizes the display to help identify flocks of birds, useful when trying to locate a fishing area.

Radar scanners: SuperHD™ Open Array, HD Open Array and HD Radome.



WEATHER

Weather mode optimizes the display to help identify precipitation, useful for helping determine weather fronts.

Radar scanners: Quantum™ and Quantum™ 2 Doppler.

12.6 Range and bearing

The Radar app helps you identify a target's range (distance) and bearing from your vessel.

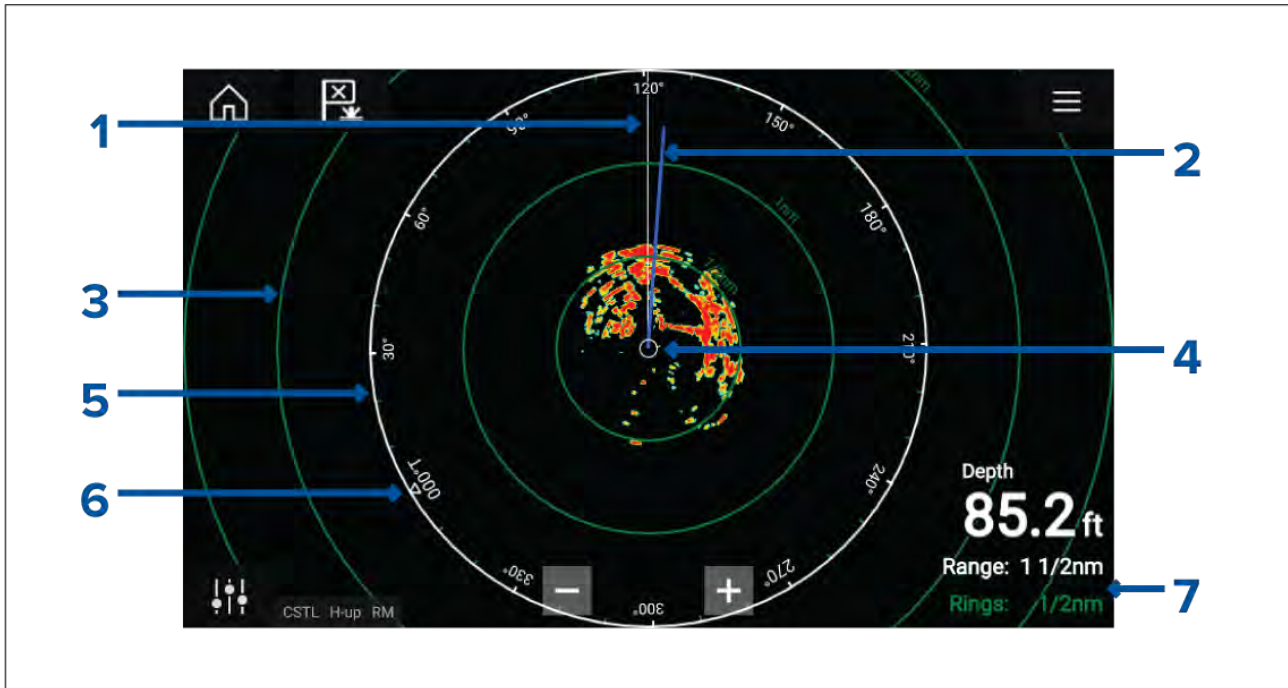

1. SHM (Ships heading marker).
2. COG/SOG line (Points in the direction of travel (COG), with the length of the vector providing an indication of speed (SOG)).
3. Range rings.
4. Vessel position.
5. Range and bearing indicator (The White ring identifies the distance from your vessel to the top edge of the screen. Bearing indicators are also provided around the ring).
6. North indicator (Always points North).
7. Current displayed Range and Ring separation distance (Range: identifies the distance from your vessel to the top edge of the screen. Rings: identifies the distance between each Range Ring).

The displayed range can be adjusted at anytime using the Range controls.

Range rings can be switched off from the Presentation tab: **Menu > Settings > Presentation > Range rings:**

You can also choose whether to display a numerical range indicator against each ring using the **Range ring labels:** option.

VRM (Variable Range Marker) / EBL (Electronic Bearing Line)

VRM/EBL is used to determine a targets range and bearing from your vessel, or from another target. 2 VRM/EBLs are available which are enabled from the context menu.

Context menu > More options > VRM/EBL 1 or **Context menu > More options > VRM/EBL 2**

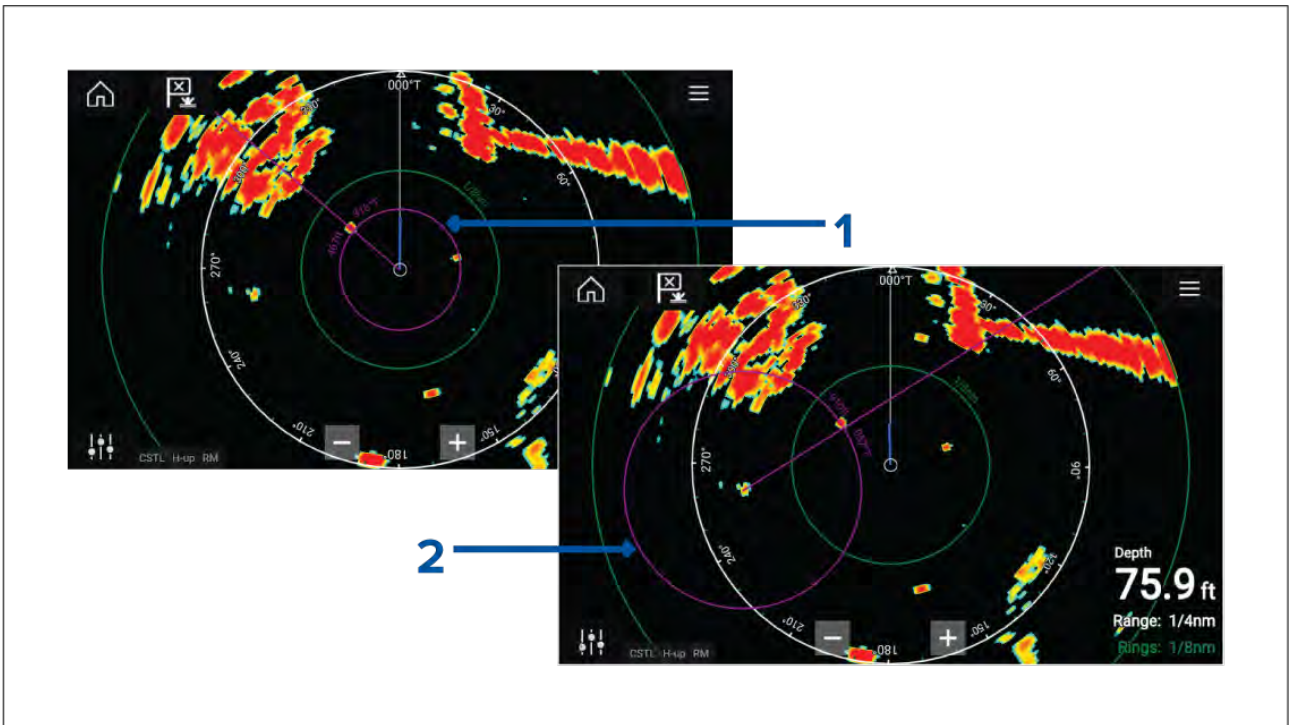

1. **Centered VRM/EBL** You can use a 'Centered' (on your vessel) VRM/EBL to determine the range and bearing of targets in relation to your vessel.
2. **Floating VRM/EBL** You can use a 'Floating' VRM/EBL to determine the range and bearing between 2 targets.

Editing a VRM-EBL

Once a VRM/EBL has been placed you can adjust its size and position.

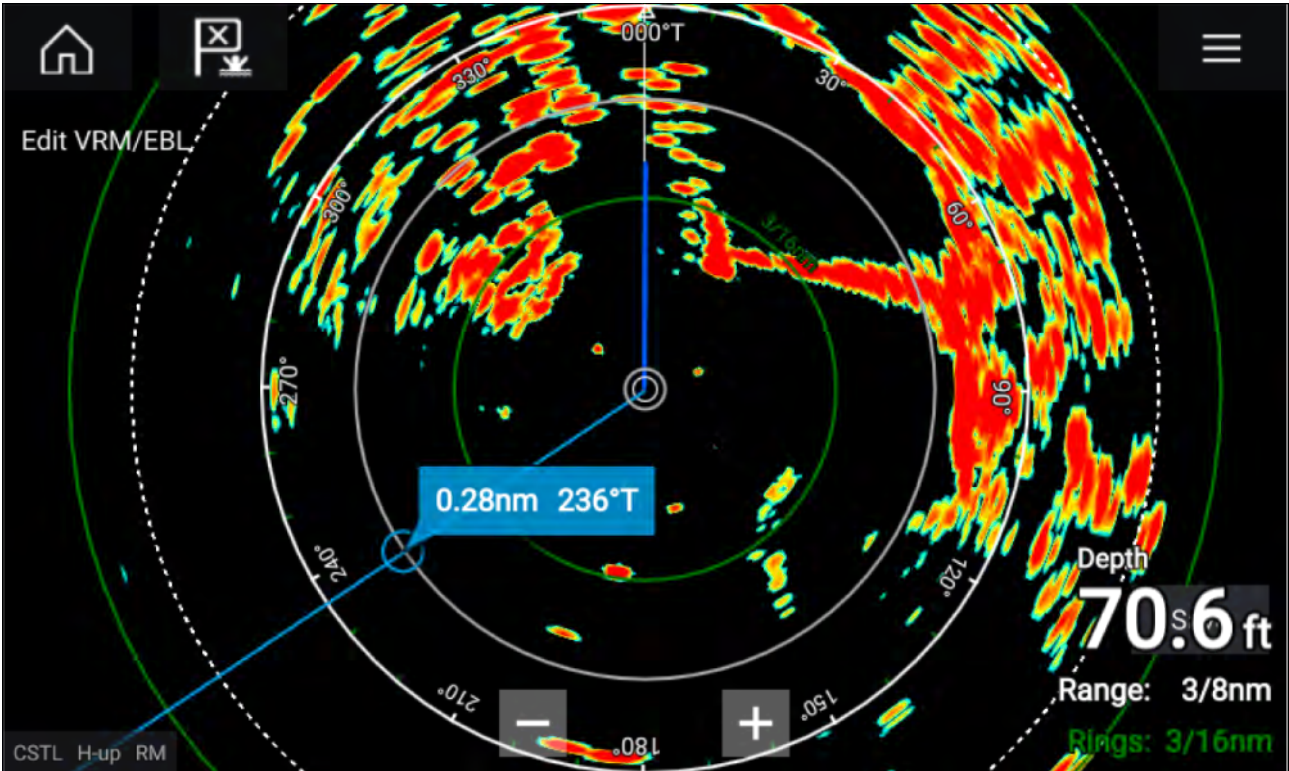

1. Select **Edit VRM/EBL** from the context menu.
2. To adjust the VRM/EBL select the desired target or drag the labelled circle to the target.
3. To create a floating VRM/EBL Drag the center circle to the desired target.

12.7 AIS targets

With compatible AIS hardware connected to your MFD, AIS targets can be automatically displayed in the Chart app and Radar app.

Tracked AIS targets are identified onscreen using target symbols.

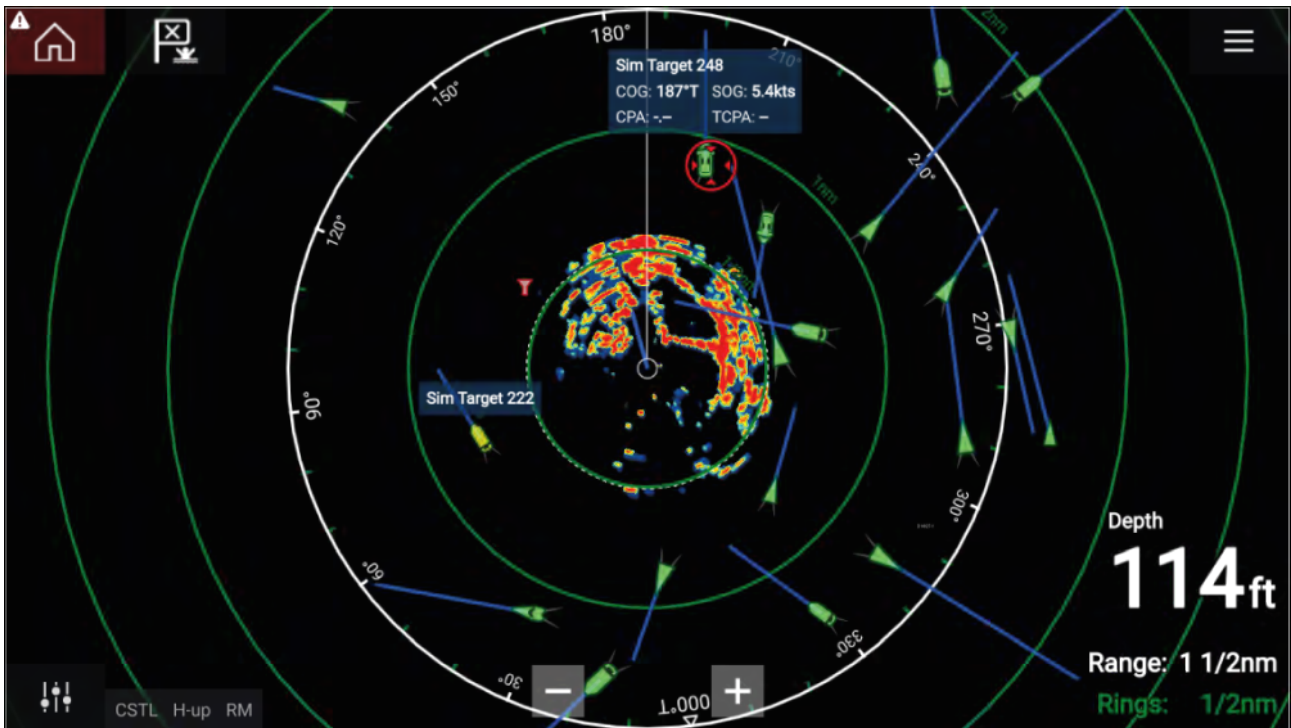

Up to 100 AIS targets can be tracked simultaneously. If more than 100 targets exist, within your range, the 100 targets nearest to your vessel will be displayed.

Target vectors and information can be displayed for each target by selecting the relevant option from the AIS target context menu. The AIS target context menu is accessed by selecting the AIS target.

You can also select the type of AIS targets that should be displayed, i.e.: **All**, **Dangerous**, **Buddies** and hide static targets from the AIS Settings tab.

AIS target list

AIS targets appear in the AIS target list.

The AIS target list can be accessed by selecting the **AIS** tab from the **Targets** menu: **Menu > Targets > AIS**.



The list identifies: Target name and Range and Bearing (from your vessel). Where relevant, CPA (Closest point of approach) and TCPA (Time to Closest Point of Approach) values are also shown.

Selecting a target from the list will highlight the selected target in the **LiveView** pane on the right of the screen and display Pop-over options. Pop-over options enable you to **View full target data** or add an AIS target a buddy by selecting **Add as buddy**.







AIS icons used for targets marked as buddies will be filled yellow. You can also rename buddy targets or remove buddies using the Pop-over options.

AIS targets

AIS icons are used to identify AIS targets onscreen.







By default the following icons are used:

AIS icons

	Vessel		SART (Search and Rescue Transponder)
	Land-based station		ATON
	SAR (Search and Rescue)		Virtual ATON

You can enable enhanced AIS target icons from the **AIS Settings** menu: **Menu > Targets > AIS Settings > Enhanced AIS targets** or the **Advanced** settings menu: **Menu > Settings > Advanced > Enhanced AIS targets**. When Enhanced AIS targets is enabled the Enhanced AIS icons are used.

Enhanced AIS icons





	Sailing Vessel		Commercial
	High speed vessel / Wing In Ground vessel		Cargo vessel
	Passenger vessel		Other

Enhanced AIS icons are scaled or outlined according to the reported size of the vessel, as shown below:

	Relative length (Gray outline)		
---	--------------------------------	--	--

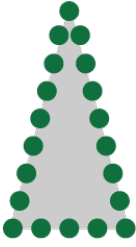
The status of an AIS target can is shown using different colors, outlines and flashing as shown below:

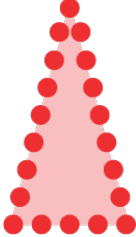
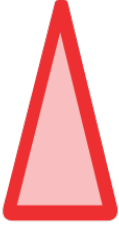
AIS target status

	Lost (No border, crossed through)		Uncertain (Dashed outline)
	Buddy (Yellow fill)		Dangerous and Uncertain (Dashed outline and Flashes Red)
	Dangerous (Flashes Red)		ATON off position (Red border)

Note:

When the MFD is configured as 'First responder' and is connected to STEDs compatible AIS hardware, Blue Force AIS icons are used to identify other STEDs equipped vessels. For details refer to: [p.220 – Blue Force Tracking](#)

AIS settings menu

You can configure AIS target settings from the **AIS Settings** menu: **Menu > Targets > AIS Settings**.

The following options are available:

- **Show AIS targets in chart / Show AIS targets in Radar** — Enables and disables display of AIS targets in the Chart app / Radar app.
- **Enhanced AIS targets** — Enables and disables the display of enhanced AIS target icons.
- **AIS names** — When enabled, AIS target names are permanently displayed next to AIS target icons.
- **Show these AIS types** — Enables selection of the types of AIS target that will be displayed.
Available AIS types:
 - All
 - Dangerous
 - Buddies
- **Hide static targets** — When enabled, AIS targets travelling under 2 knots will not be displayed, unless it is or becomes dangerous.
- **Silent mode (don't transmit my position)** — When enabled, your vessel's AIS transceiver will not transmit your position or details to other AIS equipped vessels.

12.8 Radar targets

With a compatible Radar scanner connected to your MFD, radar targets can be tracked in the Chart app and Radar app. Depending on your Radar scanner, radar targets can be acquired manually or automatically, based on your configured **Guard zones**.

Tracked radar targets are identified onscreen using target symbols.

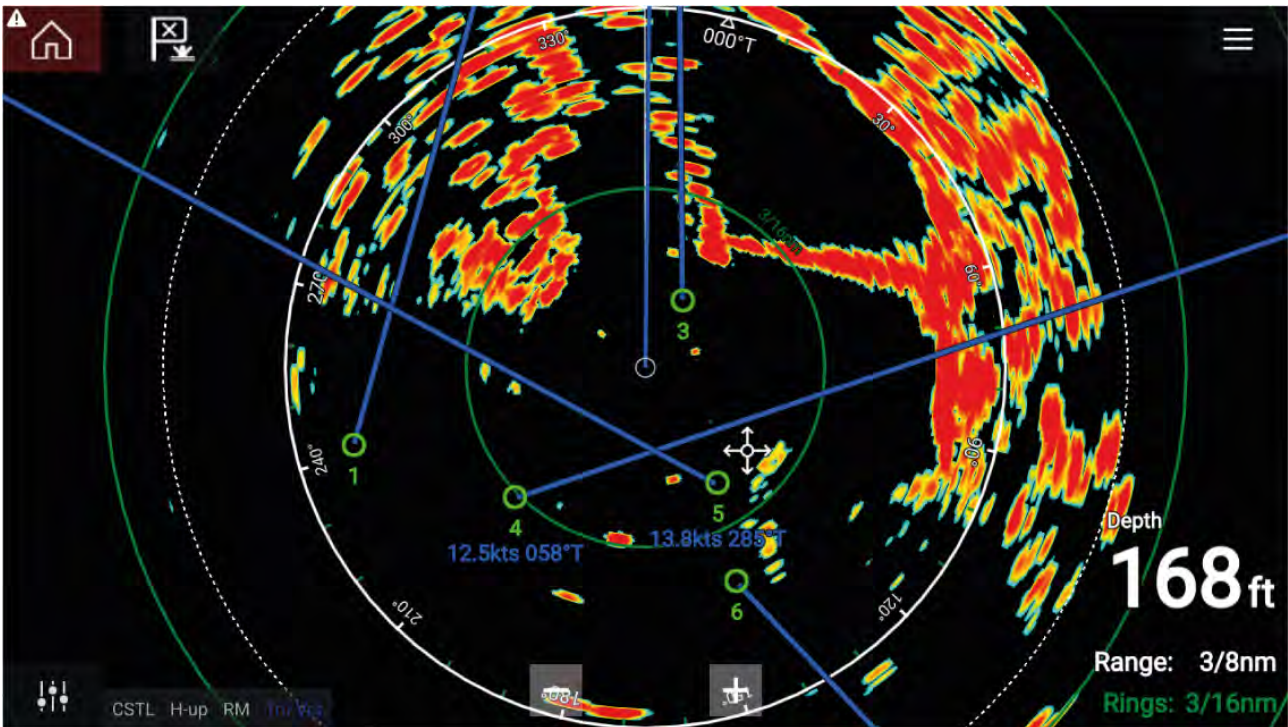

Multiple radar targets can be tracked simultaneously.

Target vectors and information can be displayed for each target.

Radar target options are available from the Radar target context menu. The Radar target context menu provides options for you to **Cancel target**, **Show CPA** graphic or display **Target info** onscreen by selecting the relevant option. The Radar context menu is accessed by selecting the radar target.

Radar target acquisition data source requirements





Radar target acquisition requires the following data sources to be available on your system (e.g. connected to your multifunction display, via SeaTalkng® or NMEA 0183).

Data type	Example data source
COG (Course Over Ground)	GPS or GNSS receiver (MFD internal receiver or external receiver).
SOG (Speed Over Ground)	GPS or GNSS receiver (MFD internal receiver or external receiver).
HDG / HDT (True Heading)	Compass or Autopilot sensor providing Fastheading data (e.g. Evolution EV-1 / EV-2).

Radar targets

Radar target symbols are used to identify Radar targets onscreen.

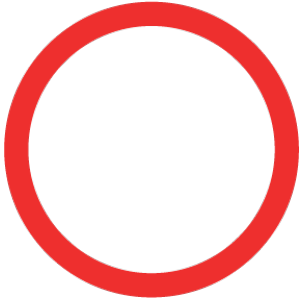
Radar targets are displayed in the Radar app and when Radar overlay is enabled (**Chart app > Menu > Targets > Radar settings > RADAR OVERLAY > Show radar overlay**) they are also displayed in the Chart app.

	Acquiring target (manual) — Thin dashed Green circle		Acquired target (manual) — Green circle with Target ID
	Acquiring target (auto) — Thick dashed Red circle, flashes until acknowledged		Unacknowledged acquired target (auto) — Red circle, flashes until acknowledged
	Dangerous target — Red circle with Target ID, flashes until acknowledged		Lost target (Target not detected for 4 Radar scans) — Gray circle with Red cross through

Once acquired the target's COG (Course Over Ground) and SOG (Speed Over Ground) can be displayed below the target ID.

The Target info is colored Blue if COG and SOG values are True or Orange if values are Relative. Target info will turn Red if the target becomes dangerous.

Acquiring a target manually

To acquire a Radar target manually using MARPA (Mini Automatic Radar Plotting Aid) follow the steps below.

1. Select the object / target.
The context menu is displayed.
2. Select **Acquire target**.
Once acquired the target will be tracked.

Automatic target acquisition

With a compatible Radar scanner connected, Radar targets can be acquired automatically.

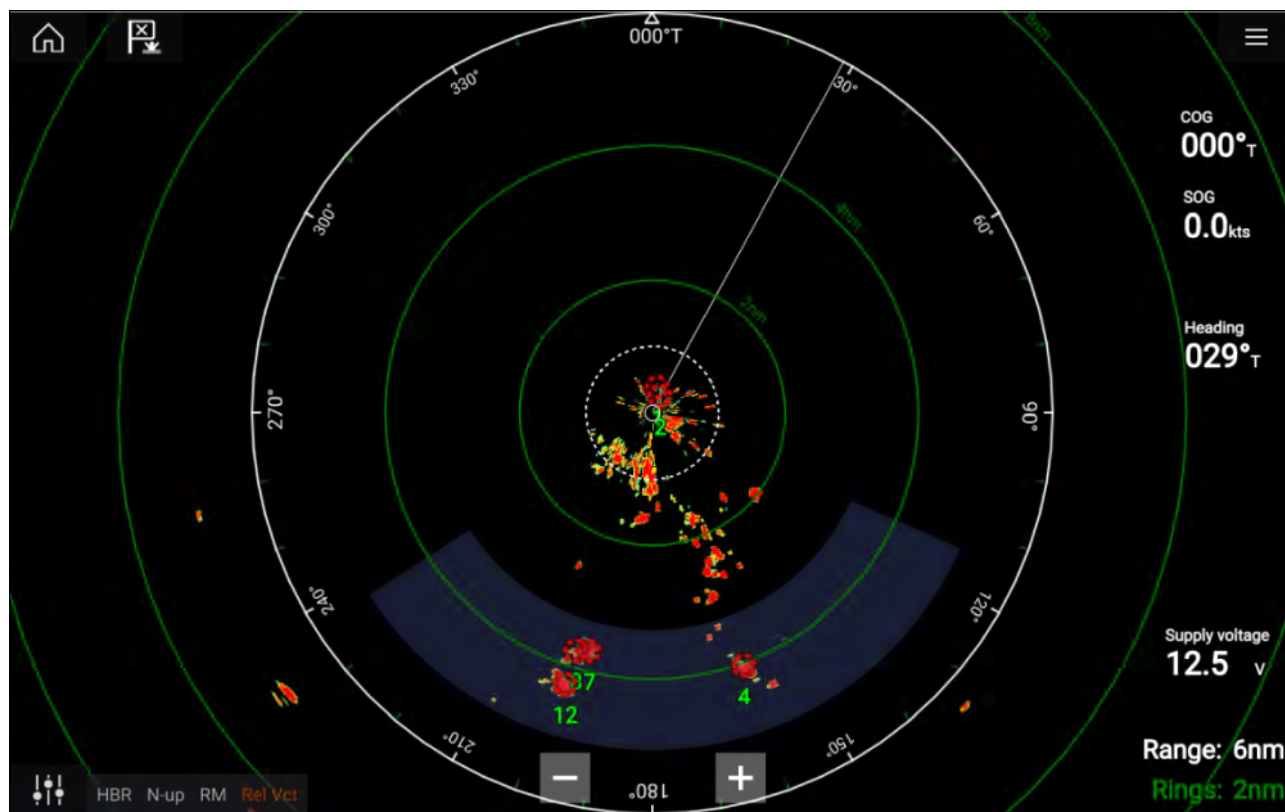

Once configured, targets which enter or appear in your chosen **Guard Zone(s)** will be automatically acquired.

Note:

- Automatic target acquisition cannot be enabled at the same time as **Timed Transmit** or **Dual Range**.
- Automatic target acquisition will be temporarily paused if the Radar display range is 12nm or greater.

Setting up automatic target acquisition

Follow the steps below to configure automatic target acquisition.

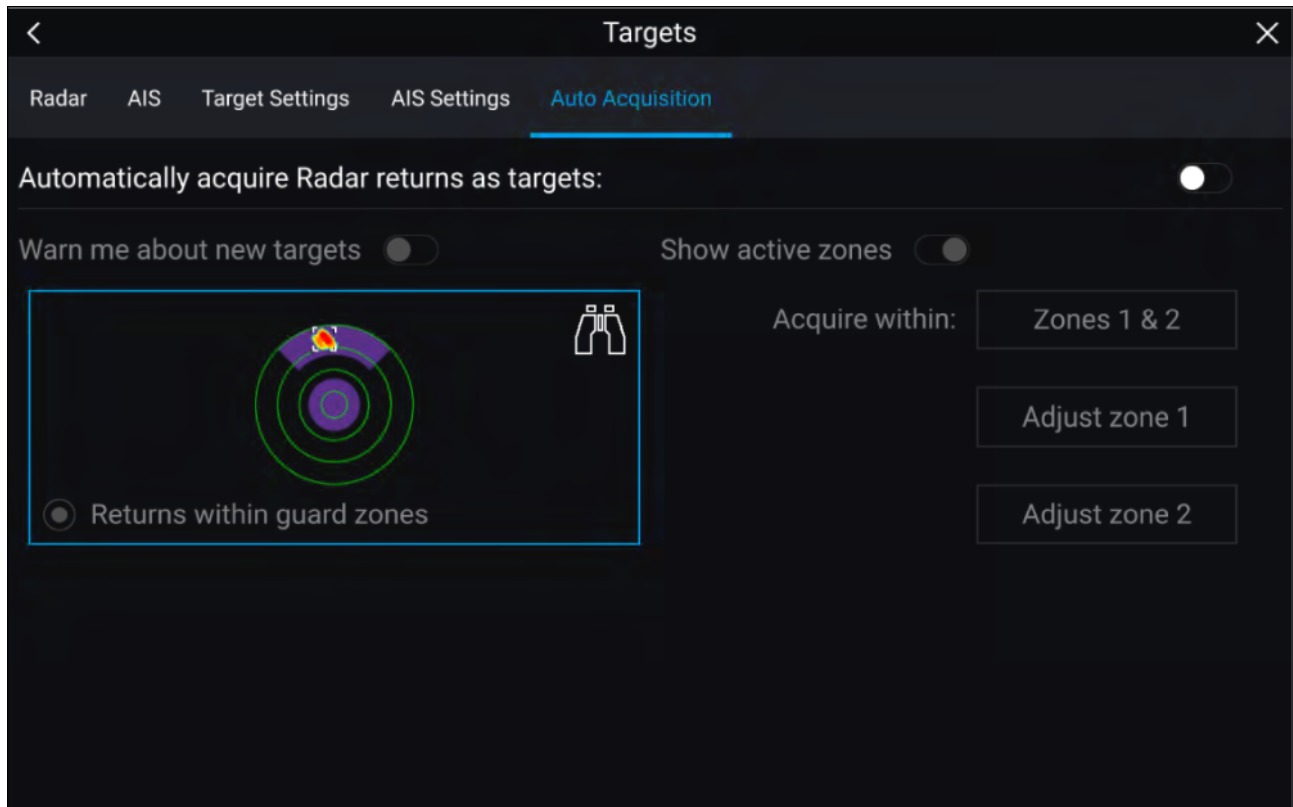

1. Select the **Auto Acquisition** tab from the Target menu: (**Menu > Targets > Auto Acquisition**).
2. Enable Automatic Target Acquisition by selecting the **Automatically acquire Radar returns as targets** toggle switch.
3. Select the **Acquire within** box and choose **Guard zone 1**, **Guard zone 2** or **Zones 1 & 2** as required.
4. To enable onscreen pop-up notifications of new targets which have been acquired automatically, select the **Warn me about new targets** toggle switch.
When multiple targets are acquired simultaneously, an Info dialog is displayed.
5. You can also adjust the size and position of the Guard zones directly from the **Auto Acquisition** page by selecting **Adjust zone 1** or **Adjust zone 2**.

Radar target list

The target list identifies: Target number, Range and Bearing from your vessel. Where relevant, CPA (Closest point of approach) and TCPA (Time to Closest Point of Approach) values will also be displayed.

The Radar target list can be accessed from the Targets menu in the Radar app and Chart app: **Menu > Targets > Radar**.

The Radar target list can be sorted by either Number or Range by selecting the **Sorted By** option located at the bottom of the LiveView pane:

- Number — List sorted by Target number so that the first detected target appears at the top of the list.
- Range — List sorted by proximity to your vessel with the closest target appearing at the top of the list. The list will automatically update as targets become closer or farther away.

Selecting a target from the list highlights the selected target in the LiveView app pane on the right of the page and opens the Pop-over menu.

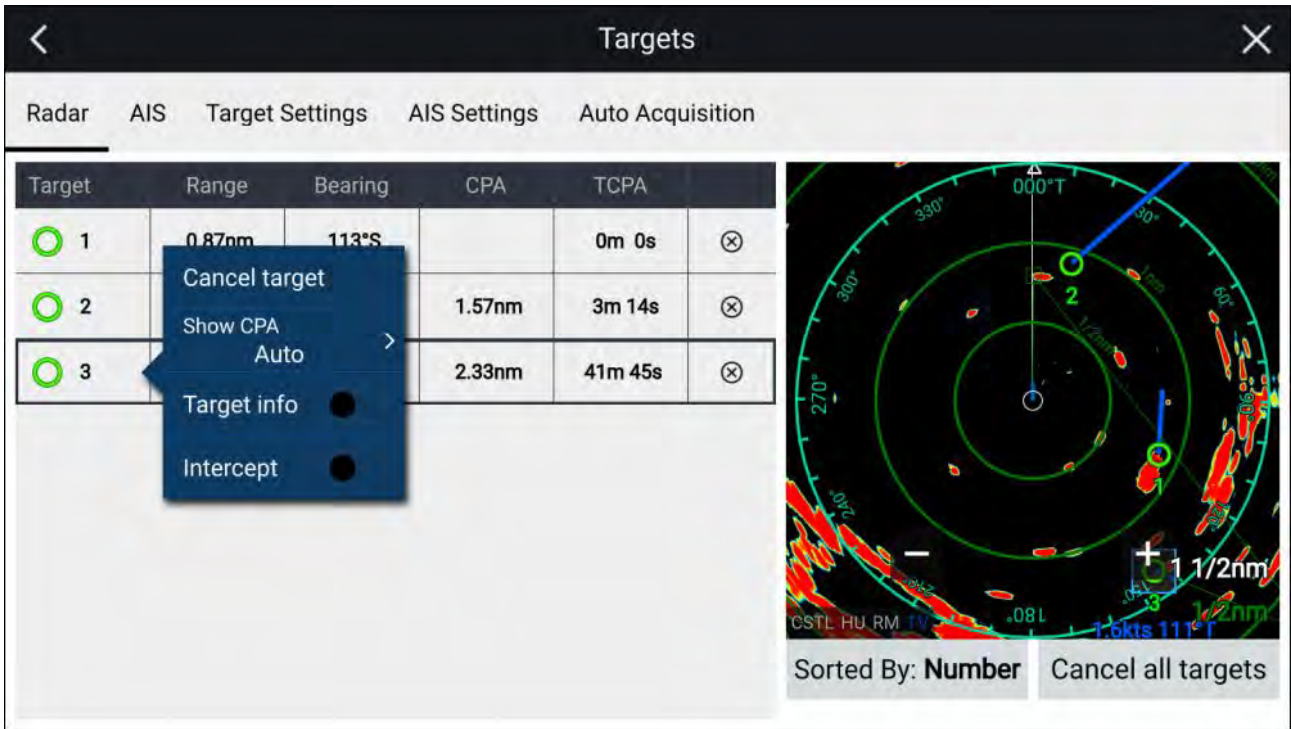

Radar targets can be cancelled individually by selecting the 'X' next to the target's details in the list, or you can cancel all targets by selecting **Cancel all targets**.

Target settings

Target vectors, target history and object trail graphics can be displayed onscreen to improve situational and collision awareness.

Target settings can be accessed from the **Target Settings** tab: **Menu > Targets > Target settings**.

Reference mode

Target settings can be configured to either **True** or **Relative** mode. In True mode, Trails, Vectors and History are colored Blue and are shown ground referenced (i.e. the object or target's actual Course Over Ground (COG)). In Relative mode, Trails, Vectors and History are colored Orange and are shown relative to your vessel's movement.

To switch the target reference mode, select the **REFERENCE MODE** setting. Alternatively, you can switch reference mode by selecting the onscreen **Image Adjustment** icon and then selecting either **True** or **Relative**.

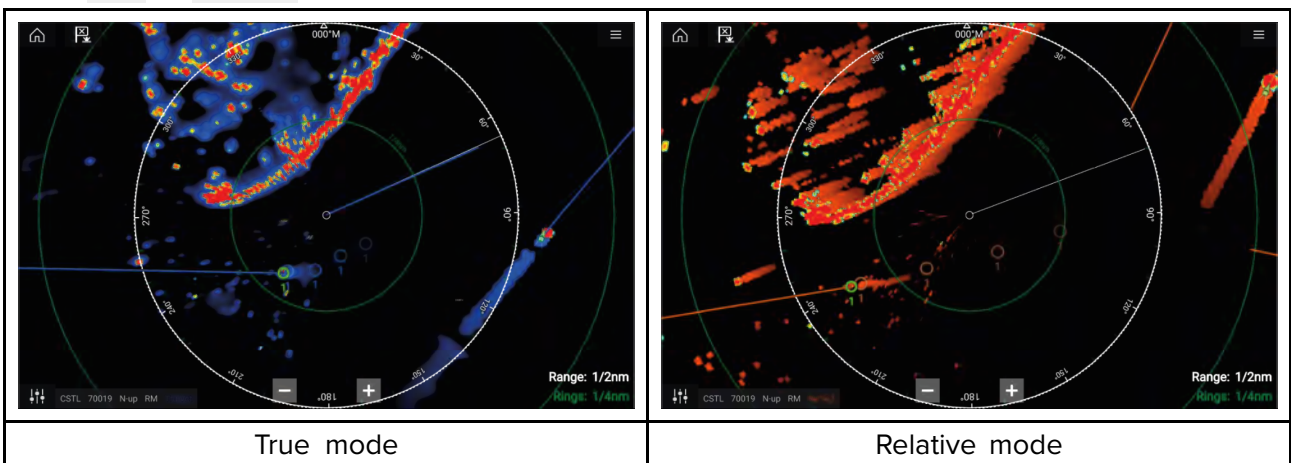

The **Target Settings** reference mode is independent of your vessel's motion mode.

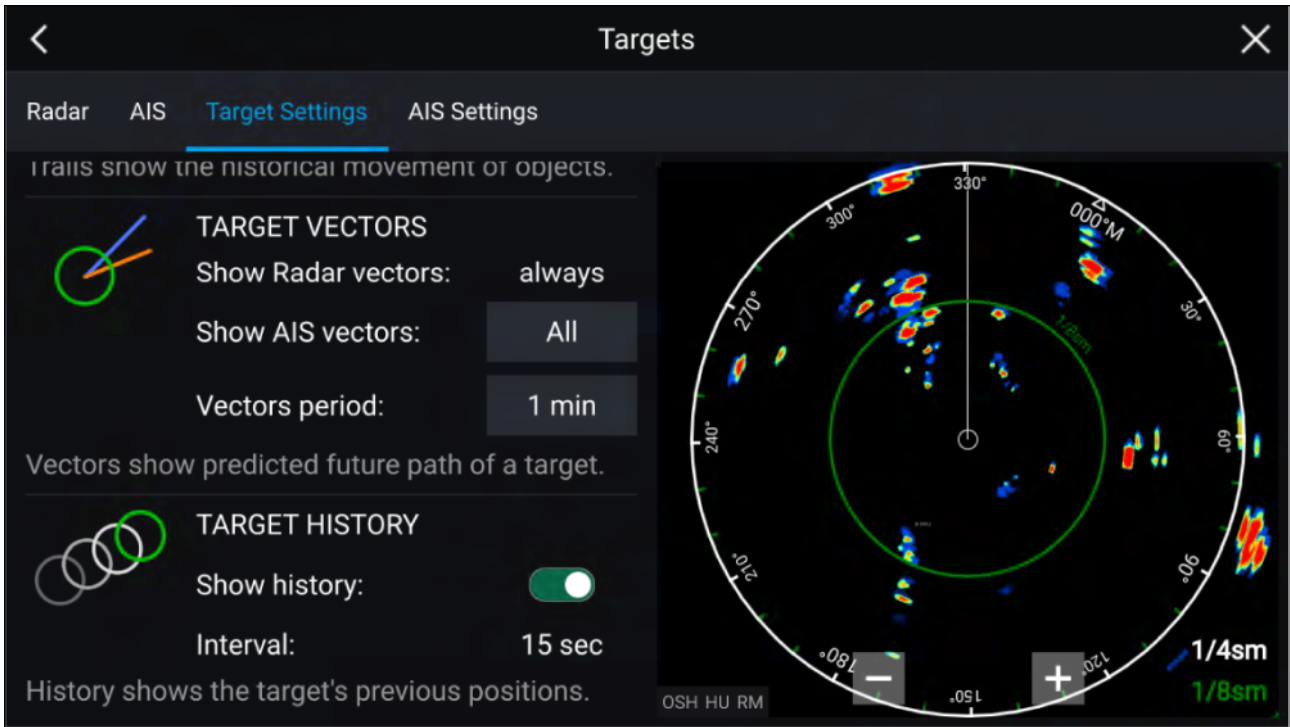

Target vectors

Target vectors show the predicted future course of a target.

Target vectors for acquired Radar targets are always shown. By default, target vectors are also shown for all AIS targets. You can switch the **Show AIS vectors** to Manual, enabling you to switch vectors for AIS targets On or Off for each target individually, via the target context menu.

The length of the Vector line signifies where the target will be after the time specified in **Vector period** has passed. The Vector period can be adjusted by selecting the current **Vector period** value and choosing a time from the Pop-over options.

Target history

Target history shows a target's previous positions.

Target history can be enabled or disabled using the **Show history** toggle switch.

Target history is plotted by displaying a target symbol at the vessel's position each time the value specified in the **Interval** setting has passed. The **Interval** is automatically calculated based on the target vector's **Vector period**, divided by 4.

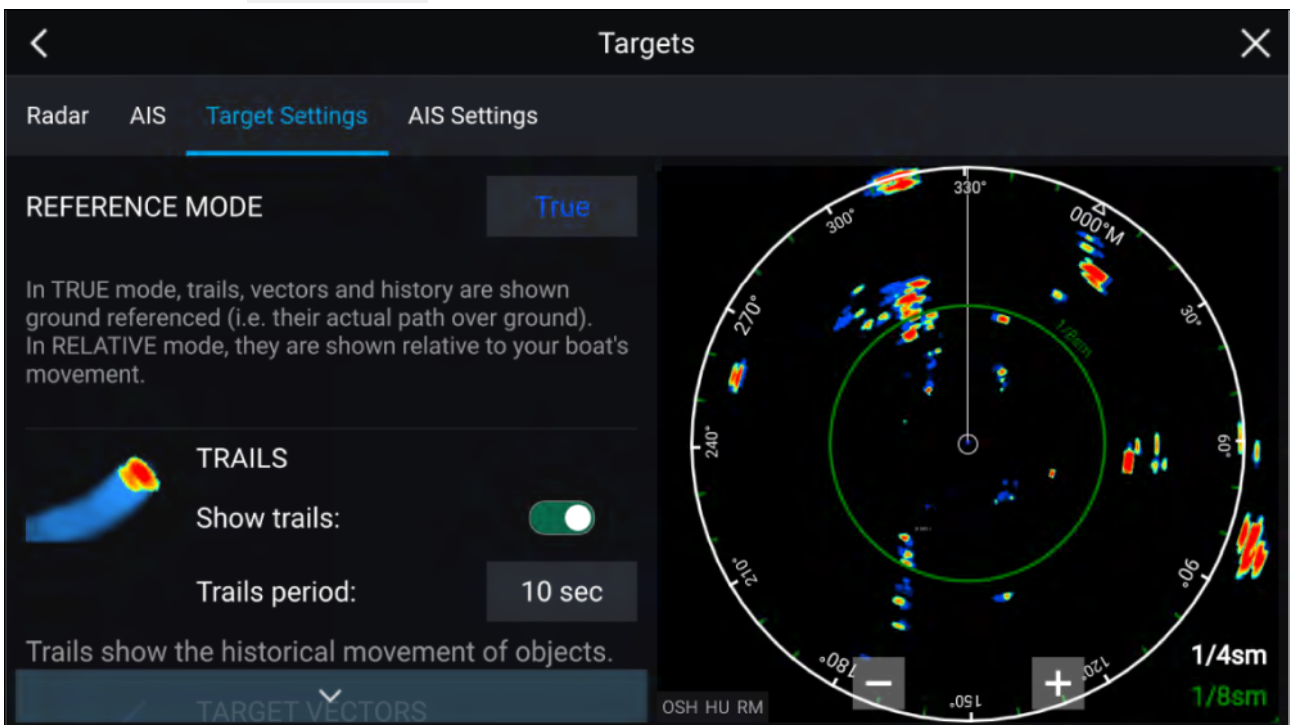

Trails

Trails plot the historical movements of objects (Radar returns) for the time specified in the **Trails period** setting.

Trails are subject to the selected “Reference Mode” (i.e. **True**, to show actual motion over “ground” (COG), or **Relative**, to show motion relative to your vessel).

Trails can be enabled and disabled using the **Show trails** toggle switch.

Historical object position is shown as a colored trail behind the object.

Onscreen target settings

Target settings and information are also available using the onscreen **Image adjustment** icon.

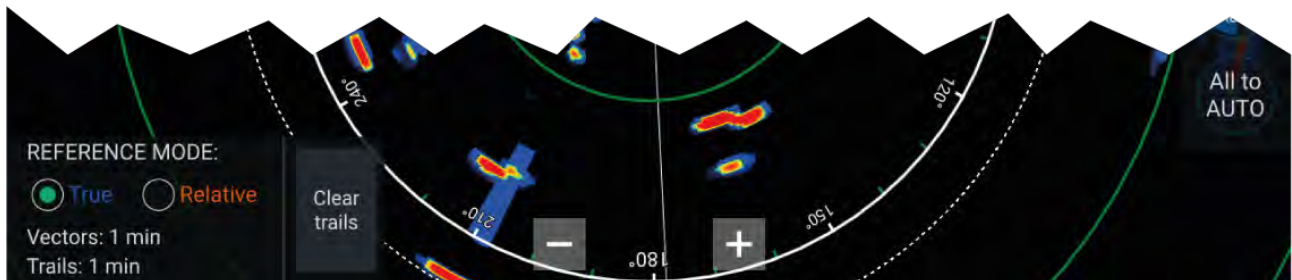

The following target settings and information is available:

- **REFERENCE MODE** — Choose whether Radar targets and objects are displayed in **True** or **Relative** reference mode.
- **Vector period and Trail interval** — Displays currently selected values.
- **Clear trails** — Clears and resets the trails displayed onscreen.

Clearing / resetting trails

In an area with multiple target returns, trails can clutter the Radar image, reducing its ability to provide a target’s path, under these circumstances you can remove all existing trails using the onscreen **Clear trails** option.

1. Select the onscreen **Image adjustment** icon.
2. Select **Clear trails**.

Target context menu

A target context menu is available that provides quick access to useful target settings.

To open the Radar target context menu, select a target onscreen.

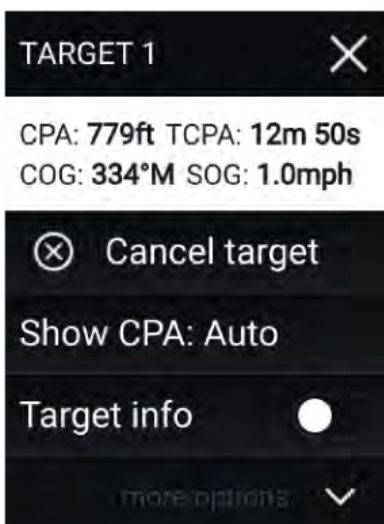

The Radar context menu provides CPA, TCPA, COG and SOG data for the selected target.

The context menu also provides the following target menu options:

- **Cancel target** — The Radar target will no longer be tracked.
- **Show CPA** — Determines whether CPA graphics are shown. The default option is Auto which displays CPA graphics for the target if it becomes dangerous. You can also set CPA graphics to On, which displays CPA graphics, if there is an intersect point between your vessel’s current course and the target’s. When set to Off no CPA graphics will be displayed for the target.
- **Target info** — Determines whether the target’s SOG and COG information is displayed under the target onscreen.

12.9 Dangerous targets alarm

You can use the Dangerous targets alarm to notify you if a Radar or AIS target will reach a specified distance from your vessel within a specified time.

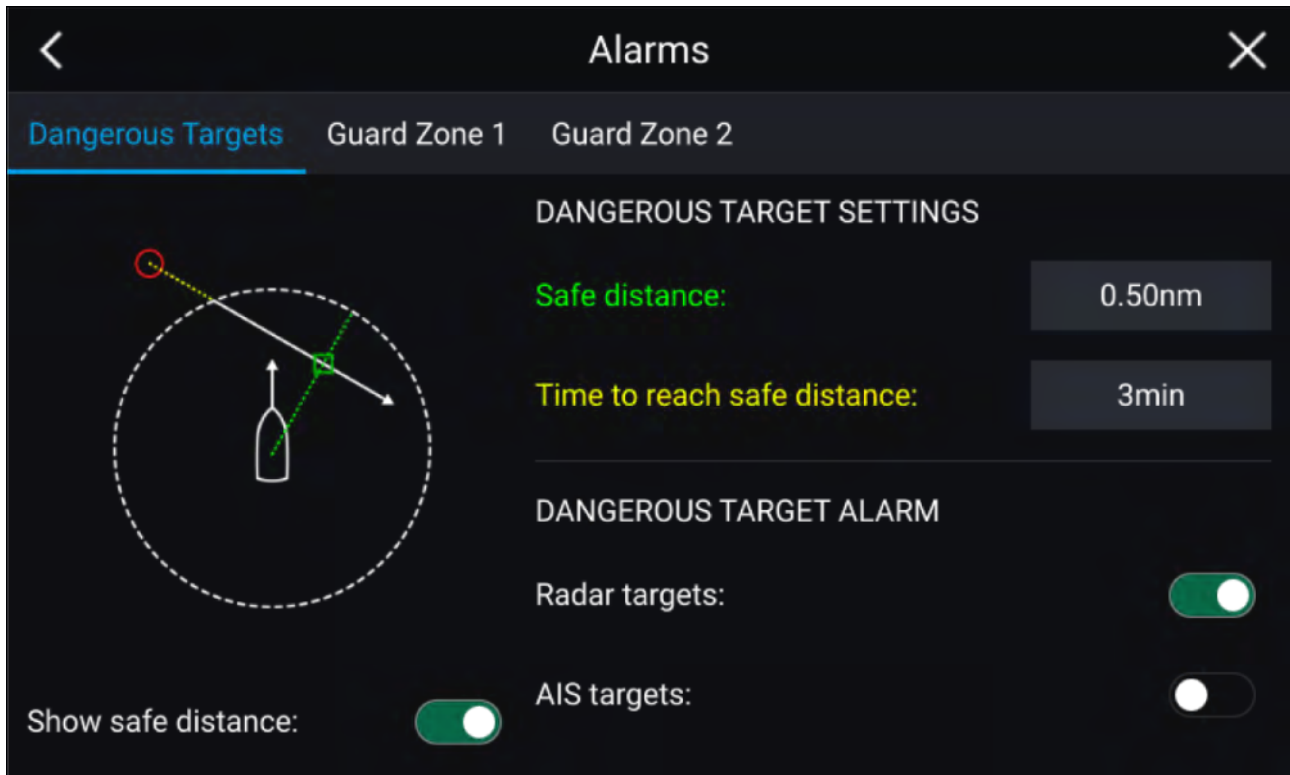

To set up the Dangerous target alarm, first adjust the **Safe distance** to the desired value and then select a **Time to reach safe distance**. The alarm will be triggered if a tracked target will reach the specified Safe distance from your vessel within the time period selected.

You can choose whether you want the Dangerous target alarm to trigger for Radar and / or AIS targets.

You can display a Safe distance ring around your vessel in the Radar app using the **Show safe distance** control.

12.10 Guard zone alarms

Guard zones alert you if a Radar return is detected within the Guard zone area.

2 Guard zones can be configured for each connected Radar scanner.

The Guard zones can be configured from the **Alarms** menu: **Menu > Alarms > Guard zone 1** or **Menu > Alarms > Guard zone 2**

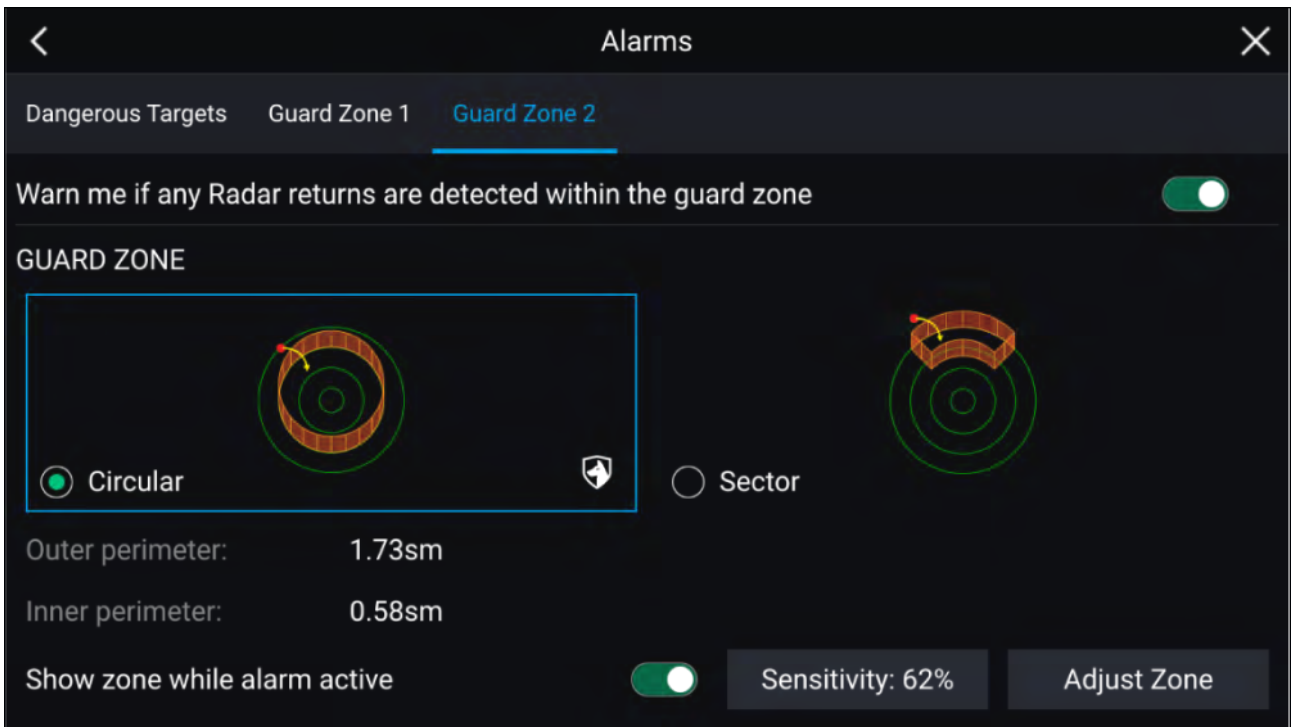

A Guard zone can be configured as a sector or as a circle around your vessel. Selecting **Adjust Zone** allows you to configure the size of the Guard Zone.



Adjust the guard zone's size by dragging the inner and outer perimeter end points (circles) to the desired locations.

Once configure select **Back**.

If required, you can also adjust the Guard zone sensitivity. Sensitivity determines the size at which objects trigger the alarm.

12.11 Doppler Radar overview

Doppler Radar technology makes it easier to track moving targets with significant ground speed exceeding 3 knots.

Typically Doppler Radar works best with objects that are moving directly towards or away from the vessel. Doppler Radar can highlight only those targets that are moving relative to the vessel (e.g. other boats, but not land or buoys, for example).

Doppler Radar works by transmitting a microwave signal which is then reflected off a desired moving target at a distance. By analyzing how the object's motion has altered the frequency of the returned signal, the Doppler Radar can interpret the variation to provide highly accurate measurements of a target's direction of travel, relative to the Radar scanner.

Doppler Radar technology is particularly beneficial in a marine environment, where poor weather conditions and visibility can make target tracking difficult. Additionally, it is not always easy to interpret the information displayed by traditional Radar technology. With the integration of Doppler information, the process of matching on-screen radar returns with real-world objects becomes a much simpler task.

Doppler mode

When a compatible Radar is connected Doppler mode is available.

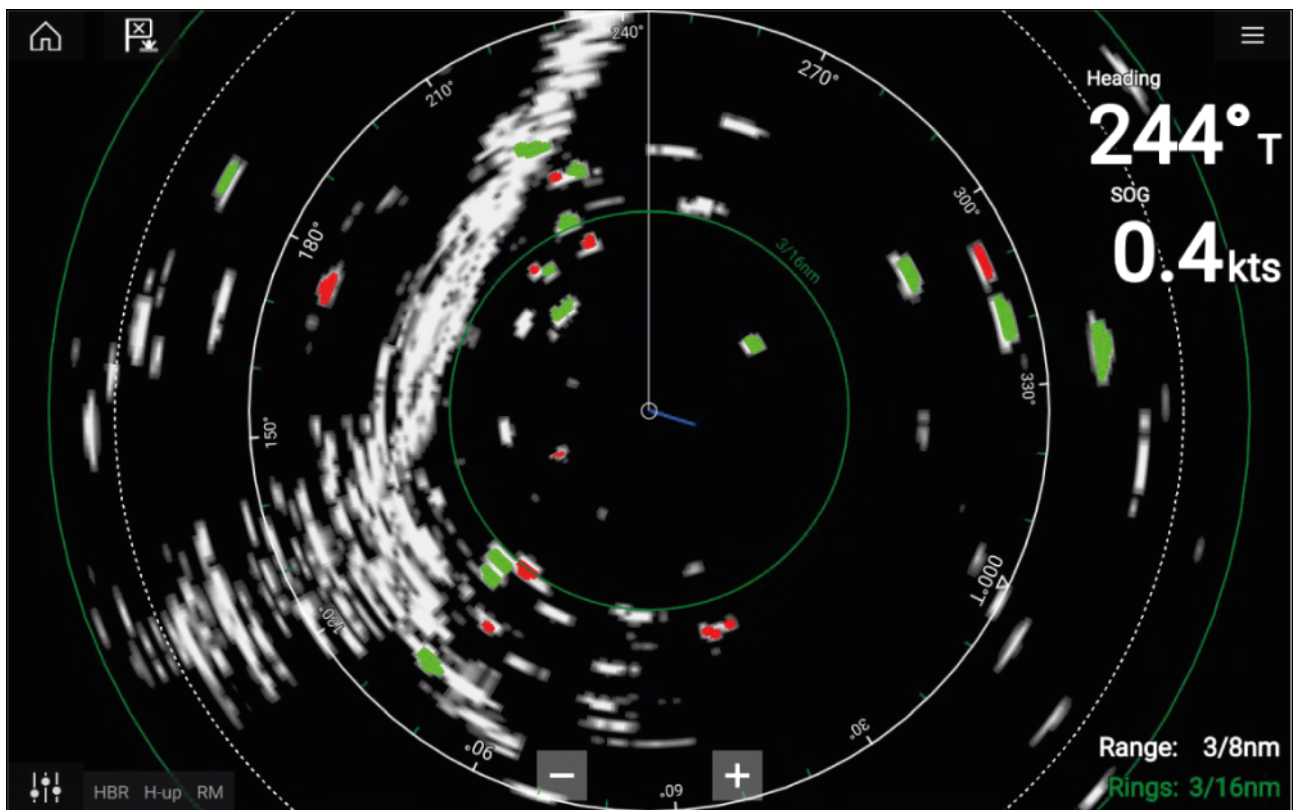

Doppler mode — Enabling and disabling

Doppler mode is enabled from the Main menu: **Menu > Doppler**.

With Doppler mode enabled the color palette will change to the default Doppler palette, all approaching targets will be colored Red and all targets moving away from you will be colored Green.

Doppler mode is suspended at ranges of 12 nm and greater. The Radar color palette will remain the same but targets will not be highlighted.

Doppler mode — Color palettes

Doppler has unique color palettes which help to ensure the Red and Green Doppler targets stand out from the Radar image. When Doppler is enabled the standard color palette setting will show only the unique Doppler color palettes: **Doppler grey**, **Doppler blue** and **Doppler yellow**.

The Color palettes can be selected from the Presentation tab: **Menu > Settings > Presentation**.

Doppler data source requirements

Use of the Doppler Radar features requires the following data sources to be available on your system (e.g. connected to your multifunction display, via SeaTalkng[®] or NMEA 0183).

Required data sources

Data type	Example data source
COG (Course Over Ground)	GPS or GNSS receiver (MFD internal receiver or external receiver).
SOG (Speed Over Ground)	GPS or GNSS receiver (MFD internal receiver or external receiver).

Recommended data source

Data type	Example data source
HDG / HDT (True Heading)	Compass or Autopilot sensor providing Fastheading data (e.g. Evolution EV-1 / EV-2).

Note:

A Heading data source is not essential for Doppler operation. However it will improve the performance of Doppler mode at slower speeds (< 15 knots), when tide set and leeway are present.

12.12 Blank sectors

Blank sectors can be manually set to hide sections of your radar display. This is useful for vessels that experience false radar readings from onboard structures or equipment.

Note:

Sector blanking is only compatible with Magnum Open Array radar scanners.

Blank sectors can be enabled from the Radar app settings: **Radar app > Settings menu > Installation**

Two blank sectors can be enabled. You can edit the minimum and maximum limits of each blank sector; this will determine how much of the radar display is hidden.

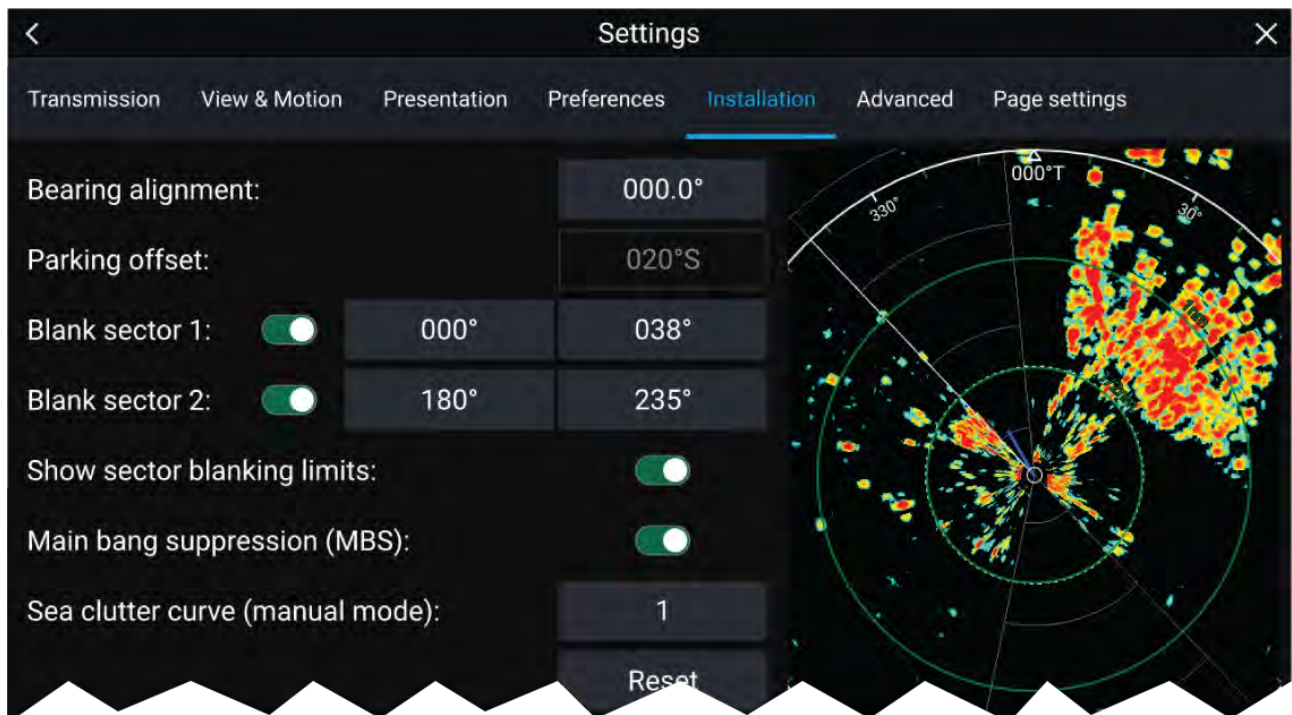

Blank sectors can be enabled / disabled on the radar overlay in the Chart app: **Chart app > Settings menu > Radar settings**

For more information refer to [Radar settings](#)

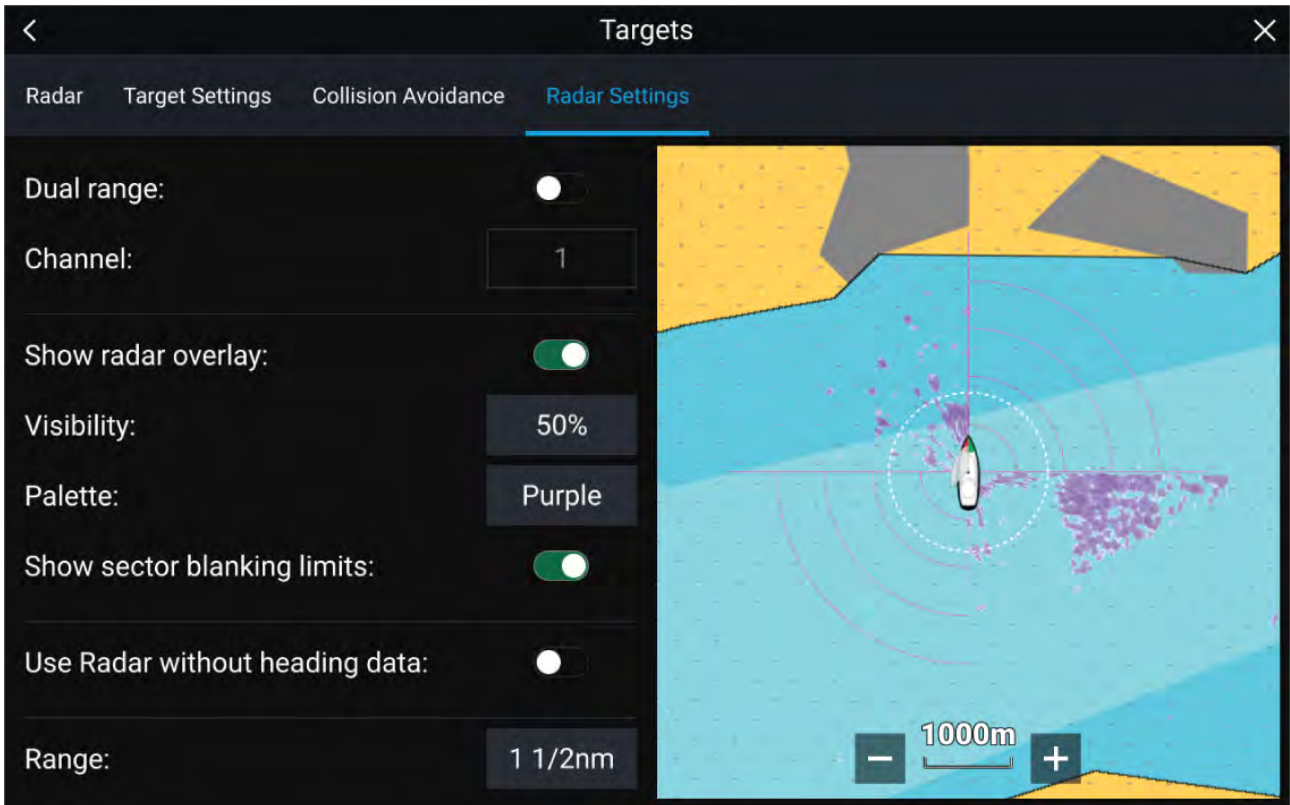



12.13 Radar sensitivity controls



Optimum performance is usually achieved using the default settings. You can adjust the image using the Sensitivity controls to improve the displayed image.



Sensitivity settings can be accessed using the onscreen **Image adjustment** icon, or the Adjust sensitivity menu option: **Menu > Adjust sensitivity**.

The Sensitivity controls available are dependant upon the Radar scanner in use.

Control	Name	Description
	'G' Gain	The control determines the signal strength at which target returns are shown onscreen. The Gain control can be set to Auto or Manual . A higher value produces more target returns and noise onscreen.
	'R' Rain	Precipitation appears on the Radar screen as lots of small echoes which continuously change size, intensity and position. The Rain control suppresses these echoes making it easier to identify real object. The higher the Rain control is set the more echoes will be suppressed.

Control	Name	Description
	'S' Sea	Radar echoes from waves can clutter the Radar screen. The Sea control suppresses these echoes (for up to 5 nm depending on conditions) making it easier to identify real objects. The higher the Sea control is set the more echoes will be suppressed.
	'CG' Color Gain	The control sets the lower limit for the color used for the strongest target returns. All target returns above this value are displayed in the strongest color. Those with a weaker value are divided equally between the remaining colors. The control can be set to Auto or Manual .
	All to Auto	Sets all Sensitivity settings to Auto with 0% offset.

12.14 Radar settings

The Settings menu provides access to the Radar app's features and functions. The options available in the Settings menu are dependent on the type of Radar scanner connected.

Transmission tab

Settings	Description	Options
Scanner	Allows you to select the Radar scanner that you want to use.	List of available Radar scanners.
Dual range	Enables and Disables dual range.	<ul style="list-style-type: none"> • On • Off
Channel	Determines which channel is shown in the Radar app.	<ul style="list-style-type: none"> • Channel 1 • Channel 2
Antenna size selection	Open Array Radar antenna size selection.	<ul style="list-style-type: none"> • 4ft • 6ft
Timed transmit	Enables and disables Timed transmit. Timed transmit configures your Radar to transmit at periodic intervals to conserve power.	<ul style="list-style-type: none"> • On • Off
Standby	Determines the length of time the Radar is in Standby for in Time transmit mode.	<ul style="list-style-type: none"> • 3 min • 5 min • 10 min • 15 min
Transmit	Determines the amount of scans the Radar will perform when transmitting in Time transmit mode..	<ul style="list-style-type: none"> • 10 scans • 20 scans • 30 scans

View & Motion tab

Settings	Description	Options
Orientation	<p>Head-up The top of the screen always points towards your vessel's current heading and as your heading changes the Radar image rotates accordingly. In Head-up the motion mode is fixed to Relative motion.</p> <p>North-up The top of the screen always points towards north and as your vessel's heading changes the SHM rotates accordingly.</p> <p>Course-up In Course-up the top of the screen always points towards your destination and as your heading changes the SHM rotates accordingly.</p>	<ul style="list-style-type: none"> • Head-up • North-up • Course-up
Motion mode	<p>Relative motion The position of your vessel remains fixed onscreen and the Radar image moves relative to your position. In Relative motion mode you can adjust your vessel's onscreen position using the Boat position setting.</p> <p>True motion Stationary Radar targets remain fixed and moving targets, including your vessel, move in true perspective to each other and to landmass. As your vessel's position reaches the edge of the screen, the image is redrawn to reveal the area ahead. In True motion mode the boat position is fixed to Full offset.</p>	<ul style="list-style-type: none"> • Relative motion • True motion
Boat position	<p>The boat position determines the position of your vessel onscreen. You can adjust the Boat position to provide a greater distance ahead of your vessel. Your boat position can only be changed in Relative motion mode.</p>	<ul style="list-style-type: none"> • Center • Partial offset • Full offset

Presentation tab

Settings	Description	Options
Range rings	Enables and disables Range rings in the Radar app.	<ul style="list-style-type: none"> • On • Off
Range ring labels	Enables and disables Range ring distance labels in the Radar app.	<ul style="list-style-type: none"> • On • Off
Color palette	Allows selection of the color palette.	List of color palettes.
Show waypoints	Allows the display of waypoint icons in the Radar app.	<ul style="list-style-type: none"> • On • Off

Preferences tab

Settings	Description	Options
VRM/EBL reference	Determines the reference point used for VRM/EBLs.	<ul style="list-style-type: none"> • True/Mag • Relative
Interference rejection	Suppresses interference from other close by Radar scanners.	<ul style="list-style-type: none"> • On • Off

Settings	Description	Options
Interference rejection level	Determines the level of suppression used. Only available when Interference rejection is enabled.	Quantum™ <ul style="list-style-type: none"> Level 1 to Level 5 Non-HD Digital Radomes <ul style="list-style-type: none"> Normal High
Target expansion	When enabled, increases the Radar pulse length to provide larger target returns.	<ul style="list-style-type: none"> On Off
Expansion level	Determines the level of expansion used. Only available when Target expansion is enabled.	<ul style="list-style-type: none"> Low High
Tune adjust	Allows you to adjust the Radar scanners receiver for maximum target returns. It is recommended that the Radar scanner is allowed to warm up for at least 10 minutes prior to making adjustments.	<ul style="list-style-type: none"> Auto Manual (0% to 100%)
Radar speed	Allows you to select the appropriate rotation speed for your range. The Auto option provides an increased refresh rate at Radar ranges up to 3 nm.	<ul style="list-style-type: none"> 24 RPM Auto (24 / 48 RPM)
Transmit frequency	Changing the Transmit frequency can reduce interference on the Radar image.	<ul style="list-style-type: none"> Low Normal High

Installation tab

Under normal circumstances it should not be necessary to adjust Installation settings.

Settings	Description	Options
Bearing alignment	Enables you to align the Radar image correctly in relation to your vessel's bow.	<ul style="list-style-type: none"> 179.5° Port to 180° Starboard
Parking offset	Allows you to select the "parked" position of your Open Array's antenna. This feature is only available when the Open Array radar scanner is in Standby.	<ul style="list-style-type: none"> 0° to 359°
Blank sector 1	<p>Allows you to hide a specific section of the radar display, creating a "blank" sector onscreen that shows no radar signal returns.</p> <hr/> <p>Note:</p> <p>Sector blanking is only compatible with Magnum Open Array radars and Lighthouse software version 3.9 or later.</p>	<ul style="list-style-type: none"> 0° to 359° 0° to 10° (default)
Blank sector 2	<p>Allows you to hide an additional section of the radar display, creating a "blank" sector onscreen that shows no radar signal returns.</p> <hr/> <p>Note:</p> <p>Sector blanking is only compatible with Magnum Open Array radars and Lighthouse software version 3.9 or later.</p>	<ul style="list-style-type: none"> 0° to 359° 180° to 190° (default)

Settings	Description	Options
Main Bang Suppression (MBS)	MBS eliminates saturation immediately around your vessel. When adjusting Zero range it is recommended that MBS is set to Off.	<ul style="list-style-type: none"> • Off • On
Sea clutter curve	Adjusts the Radar scanner's sensitivity to Sea clutter.	<ul style="list-style-type: none"> • 1 to 8

Advanced tab

Under normal circumstances it should not be necessary to adjust Advanced settings.

Settings	Description	Options
Tune preset	Radar tuning is controlled either automatically or manually, using the Tune adjust setting. Tune preset controls the range available to the Tune adjust control.	<ul style="list-style-type: none"> • 0 to 255
STC preset	The Sensitivity Time Control (STC) can be used to equalize targets across the image. If you find targets are brighter or dimmer nearer the center of the image adjust the STC preset until the desired result is achieved.	<ul style="list-style-type: none"> • 0% to 100%
Zero range	Zero range (Display timing) is used to configure the zero range of the Radar scanner so that objects appear at the correct distance.	<ul style="list-style-type: none"> • 0 to 153m / 502ft
Reset	Resets Installation and advanced settings to factory defaults.	<ul style="list-style-type: none"> • Yes • No

Page settings tab

Settings	Description
Data Overlays	Enables configuration of Data overlays
Edit split ratio	Enables you to customize the position of the partitions in splitscreen app pages.

Chapter 13: Dashboard app

Chapter contents

- [13.1 Dashboard app overview on page 290](#)
- [13.2 Default data pages on page 291](#)
- [13.3 Customizing existing Data pages on page 292](#)
- [13.4 Dashboard settings menu on page 297](#)
- [13.5 Navigation and Sailing dials on page 299](#)

13.1 Dashboard app overview

The Dashboard app enables you to view system data. System data may be generated by your MFD or by devices connected to your MFD via SeaTalkng[®] / NMEA 2000 and SeaTalkhs[™]. The Dashboard app can also be configured to provide control of your compatible Digital Switching devices.

Note: For data to be available in the Dashboard app it must be transmitted to your MFD from compatible hardware using supported protocols and messages.





The Dashboard app can be displayed in Fullscreen and half screen portrait app pages.



For each instance of the Dashboard app you can select which Data pages you want to use, the Data page selection will persist over a power cycle.



The Dashboard app is pre-configured with a number of customizable data pages.

Dashboard app controls

Icon	Description	Function
	Home icon	Takes you to the Homescreen.
	Waypoint / MOB	Place waypoint / activate Man overboard (MOB) alarm.
	Pilot icon	Opens and closes the Pilot Sidebar
	Menu icon	Opens the app menu.

Icon	Description	Function
	Left arrow	Displays the previous data page.
	Right arrow	Displays the next data page.

Switching data page

1. Use the **Left arrow** and **Right arrow** buttons, located at the bottom of the screen, to cycle through the available data pages.
2. Alternatively, you can select a specific data page from the Dashboard app menu.

Selecting Data pages to display

For each instance of the Dashboard app you can select which Data pages you want to be able to view.

1. Select the **Pages** tab: **Menu > Settings > Pages**.
2. Select the relevant page from the list.
3. Select **Hide page** from the pop-over options.

The selected page will no longer be available in the current instance of the Dashboard app.

*Selecting **Show page** for a hidden page will include the page in the app instance again.*

13.2 Default data pages

The Dashboard app comes with a selection of default data pages:

- Engines
- Sailing (only shown if boating activity is set to Sailing in startup wizard)
- Race start (only shown if boating activity is set to Sailing in startup wizard)
- Navigation
- Rolling road with data
- Tanks
- Bidata
- Single data
- Fuel

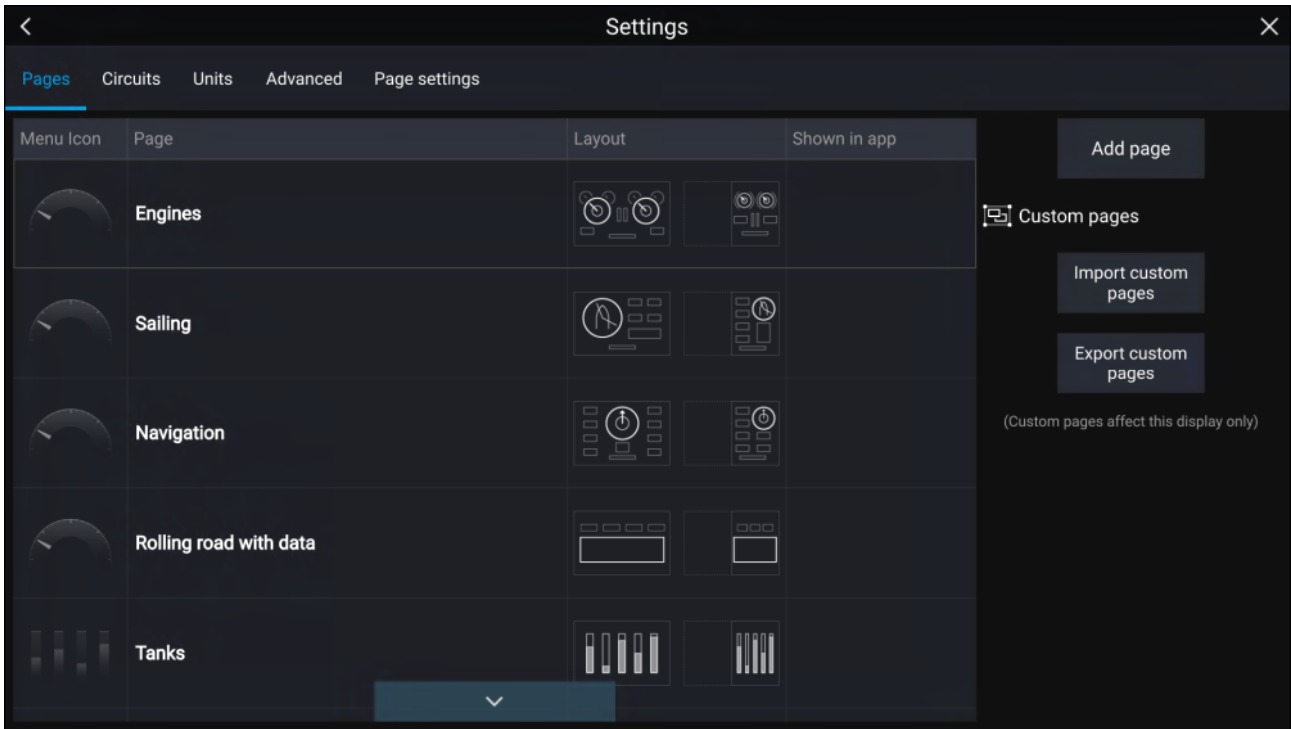

The displayed data items on each of these pages can be customized.

13.3 Customizing existing Data pages

The data items displayed on each page can be changed.

1. Select and hold on the relevant Data item.
2. Select **Edit** from the Data item pop-over menu.
3. Select the new Data item that you want to display.

Alternatively you can select **Customize page** from the app menu: **Menu > Customize page**.

Data overlay and Sidebar data items

The following data items are available for display in the Dashboard app, in Data overlays and Sidebars.

Note:

For data to be available compatible sensors and transducers are required to be connected to the same data network as the MFD.

Data category	Data items
<p>Battery Battery related data. Data items are available for the number of batteries specified in the Boat details settings: Homescreen > Settings > Boat details > Num of batteries.</p>	<ul style="list-style-type: none"> • Battery voltage • Battery current • Time till zero charge • Battery temperature • State of charge
<p>Boat</p> <p>Note:</p> <ul style="list-style-type: none"> • (1) Data item is only available in the Dashboard app 	<ul style="list-style-type: none"> • Roll • Mast rotation • Rate of turn • Trim tabs⁽¹⁾

Data category	Data items
<p>Depth Depth related data.</p>	<ul style="list-style-type: none"> • Maximum depth • Minimum depth • Depth
<p>Display Data relating to the voltage supplied to the MFD.</p> <hr/> <p>Note:</p> <ul style="list-style-type: none"> • (1) Data item is only available in Sidebars and data overlays. • (2) Data item is only available in Sidebars. 	<ul style="list-style-type: none"> • Supply voltage⁽¹⁾ • Supply voltage level⁽²⁾
<p>Distance</p> <hr/> <p>Note:</p> <ul style="list-style-type: none"> • (1) Data item is only available in the Dashboard app 	<ul style="list-style-type: none"> • Distance to line • Distance to tack • Trip (manual) • Trip (month) • Trip (day) • Trip (season) • Line bias • Ground log • Trip • Log • Log Trip⁽¹⁾
<p>Engine Engine related data requires data connection to compatible vessel engine(s). Data items are available for the number of engines specified in the Boat details settings: Homescreen > Settings > Boat details > Num of engines</p>	<ul style="list-style-type: none"> • Engine trip • Trans oil temp • Fuel flow (avg) • Trans oil pressure • Gear • Engine load • Alternator • Oil temperature • Oil pressure • Engine RPM • Engine hours • Coolant temperature • Coolant pressure • Boost pressure • Fuel pressure • Fuel flow (inst) • Fuel flow • Tilt position

Data category	Data items
<p>Fuel Data related to fuel economy. An 'All tanks' category is available when more than 1 fuel tank has been specified that combines data from all fuel tanks.</p>	<ul style="list-style-type: none"> • Est. fuel remaining • Total fuel (vol) • (vol) • (%) • Total fuel (%) • Engine economy total • Time to empty • Distance to empty • Fuel flow total • Fuel used (trip) • Fuel used (season)
<p>Environment</p> <hr/> <p>Note:</p> <ul style="list-style-type: none"> • (1) Data item is only available in the Dashboard app 	<ul style="list-style-type: none"> • Drift • True wind chill • App wind chill • Set • Max water temp • Min water temp • Water temp • Max air temp • Min air temp • Humidity • Dew point • Barometric pressure • Air temp • Sunset Sunrise⁽¹⁾ • Set Drift⁽¹⁾ • Water & Supply⁽¹⁾
<p>Inside Environment Data items are available for the number of interior environment sensors specified in the Boat details settings: Homescreen > Settings > Boat details > Num of interior environment sensors.</p>	<ul style="list-style-type: none"> • Inside humidity • Inside temperature
<p>GPS</p> <hr/> <p>Note:</p> <ul style="list-style-type: none"> • (1) Data item is only available in the Dashboard app 	<ul style="list-style-type: none"> • Cursor position • Loran cursor position • Loran position • Vessel position • SOG (Speed Over Ground) • Course over ground • Average SOG • Maximum SOG • COG SOG (Course Over Ground) (Speed Over ground)⁽¹⁾

Data category	Data items
<p>Heading</p> <hr/> <p>Note:</p> <ul style="list-style-type: none"> • (1) Steer to layline is only available when boating activity is set to Sailing in the initial MFD start up wizard. • (2) Data item is only available in the Dashboard app 	<ul style="list-style-type: none"> • Steer to layline⁽¹⁾ • Heading error • Tack heading • Locked heading • Heading • Locked heading & Error⁽²⁾ • Heading & Speed⁽²⁾
<p>Navigation</p> <hr/> <p>Note:</p> <ul style="list-style-type: none"> • (1) Data item is only available in the Dashboard app 	<ul style="list-style-type: none"> • Sailing Wpt TTG (Waypoint Time To Go) • Sailing Dist to Wpt (Distance To Waypoint) • Next waypoint • Loran target position • Cross tack error • Waypoint TTG (Time To Go) • Route TTG (Time To Go) • Target position • Waypoint ETA (time & date) (Estimated Time of Arrival) • Route ETA (time & date) (Estimated Time of Arrival) • Distance to waypoint • Distance made good • Course made good • Bearing Origin to Waypoint • Bearing to waypoint • Active waypoint • Route ETA (Estimated Time of Arrival) • Waypoint ETA (Estimated Time of Arrival) • CTS & DTW⁽¹⁾ (Course To Steer & Distance To Waypoint) • CMG & VMG⁽¹⁾ (Course Made Good & Velocity Made Good) • BTW & DTW⁽¹⁾ (Bearing To Waypoint & Distance To Waypoint) • Waypoint info⁽¹⁾ • CMG & DMG⁽¹⁾ (Course Made Good & Distance Made Good)
<p>Pilot</p>	<ul style="list-style-type: none"> • Rudder angle

Data category	Data items
<p>Speed</p> <hr/> <p>Note:</p> <ul style="list-style-type: none"> (1) Polar performance is only available when boating activity is set to Sailing in the initial MFD start up wizard. 	<ul style="list-style-type: none"> VMG to waypoint (Velocity Made Good) Speed thru water VMG to windward (Velocity Made Good) Avg speed Max speed Target speed Polar performance⁽¹⁾
<p>Time</p> <hr/> <p>Note:</p> <ul style="list-style-type: none"> (1) Data item is only available in the Dashboard app 	<ul style="list-style-type: none"> Sunset time Sunrise time UTC date (Universal Time Coordinated) UTC time (Universal Time Coordinated) Race timer⁽¹⁾ Date Time Time to tack Time to burn
<p>Wind</p> <hr/> <p>Note:</p> <ul style="list-style-type: none"> (1) Data item is only available in the Dashboard app 	<ul style="list-style-type: none"> True wind angle Cardinal Beaufort Ground wind direction Ground wind speed True wind direction Minimum true wind angle Maximum true wind angle Minimum true wind speed True wind speed Maximum app wind speed App wind speed Minimum app wind angle App wind angle Maximum app wind angle Minimum app wind speed Minimum true wind speed GWD & Beaufort⁽¹⁾ (Ground Wind Direction) GWS & GWD⁽¹⁾ (Ground Wind Speed & Ground Wind Direction) AWA & VMG⁽¹⁾ (Apparent Wind Angle & Velocity Made Good) AWA & AWS⁽¹⁾ (Apparent Wind Angle & Apparent Wind Speed) TWA & VMG wind⁽¹⁾ (True Wind Angle & Velocity Made Good)

Data category	Data items
	<ul style="list-style-type: none"> TWA & TWS⁽¹⁾ (True Wind Angle & True Wind Speed)
Fuel (Gasoline)	<ul style="list-style-type: none"> %
Fresh water	<ul style="list-style-type: none"> %
Live well	<ul style="list-style-type: none"> %
Grey water	<ul style="list-style-type: none"> %
Black water	<ul style="list-style-type: none"> %

13.4 Dashboard settings menu

Pages tab

The Pages tab provides a list of all available pages.

Settings	Description	Options
Page list	<p>Pop-over options allow you to customize the Dashboard app. You can rearrange pages, add new pages, rename existing pages or reset pages to default settings.</p> <p>Note: * You can only delete pages added using the Add page option.</p>	<ul style="list-style-type: none"> Hide/Show page Move up Move down Add page * Delete page Rename Reset all
Add page	You can add new dashboard pages that you can customize by selecting Add page .	Displays pop-over with page layouts.
Import custom pages	You can import digital switching pages . Please refer to Raymarine Product support for more details.	Displays file browser
Export custom pages	You can export your digital switching pages so that they can be restored at a later date. You must use this feature if you wish to export or backup your digital switching pages, as digital switching pages are not included in the standard MFD “Backup and restore” process, which is used to backup user settings only. Please refer to Raymarine Product support for more details. Exporting digital switching pages must be performed on each MFD configuration.	Save dialog

Circuits tab

Settings	Description	Options
List of tripped channels	In Digital Switching systems, the circuit tab provides a list of tripped channels. Tripped circuits can be acknowledged and reset from the pop-over options.	<ul style="list-style-type: none"> Acknowledged Reset

Units tab

Measurement	Units
Distance units	<ul style="list-style-type: none"> • Nautical Miles • NM & m • Statute Miles • Kilometers
Speed units	<ul style="list-style-type: none"> • Kts • MPH • KPH
Depth units	<ul style="list-style-type: none"> • Meters • Feet • Fathoms
Temperature units	<ul style="list-style-type: none"> • Celsius • Fahrenheit
Date format	<ul style="list-style-type: none"> • MM:DD:YYYY • DD:MM:YYYY • MM:DD:YY • DD:MM:YY
Volume units	<ul style="list-style-type: none"> • US Gallons • Imperial Gallons • Liters
Economy units	<ul style="list-style-type: none"> • Distance per Volume • Volume per Distance • Liters per 100 km
Wind speed units	<ul style="list-style-type: none"> • Knots • Meters per Second
Pressure units	<ul style="list-style-type: none"> • Bar • PSI • Kilopascals
Time format	<ul style="list-style-type: none"> • 12hr • 24hr

Settings	Description	Options
Bearing mode	Determines how bearing and heading data is displayed.	<ul style="list-style-type: none"> • True • Magnetic
System Datum	Determines the datum used by your MFD. This should be set to the same datum used by your paper charts.	List of available datums.
Variation	When set to Auto the MFD will automatically compensate for the naturally-occurring offset of the Earth's magnetic field.	<ul style="list-style-type: none"> • Auto • Manual
Manual variation	When variation is set to Manual , you can specify an offset.	<ul style="list-style-type: none"> • 30° W to 30° E

Advanced tab

Settings	Description	Options
Maximum RPM	You can select a maximum RPM for your engine dials, or allow the system to automatically configure the Maximum RPM.	<ul style="list-style-type: none"> • Auto • 3,000 RPM to 10,000 RPM
Custom RPM Red zone	You can create a custom Red zone for your RPM dials.	<ul style="list-style-type: none"> • 0 RPM to 10,000 RPM
Wind angle response	You can configure the rate at which Wind angle data is updated on the MFD. The Higher the response setting the faster the update rate will be.	<ul style="list-style-type: none"> • 1 to 15
Wind speed response	You can configure the rate at which Wind speed data is updated on the MFD. The Higher the response setting the faster the update rate will be.	<ul style="list-style-type: none"> • 1 to 15

Page settings tab

Settings	Description
Data Overlays	Enables configuration of Data overlays
Edit split ratio	Enables you to customize the position of the partitions in splitscreen app pages.

13.5 Navigation and Sailing dials

Navigation and Sailing dials are available which provide a compass dial with various data indicators.

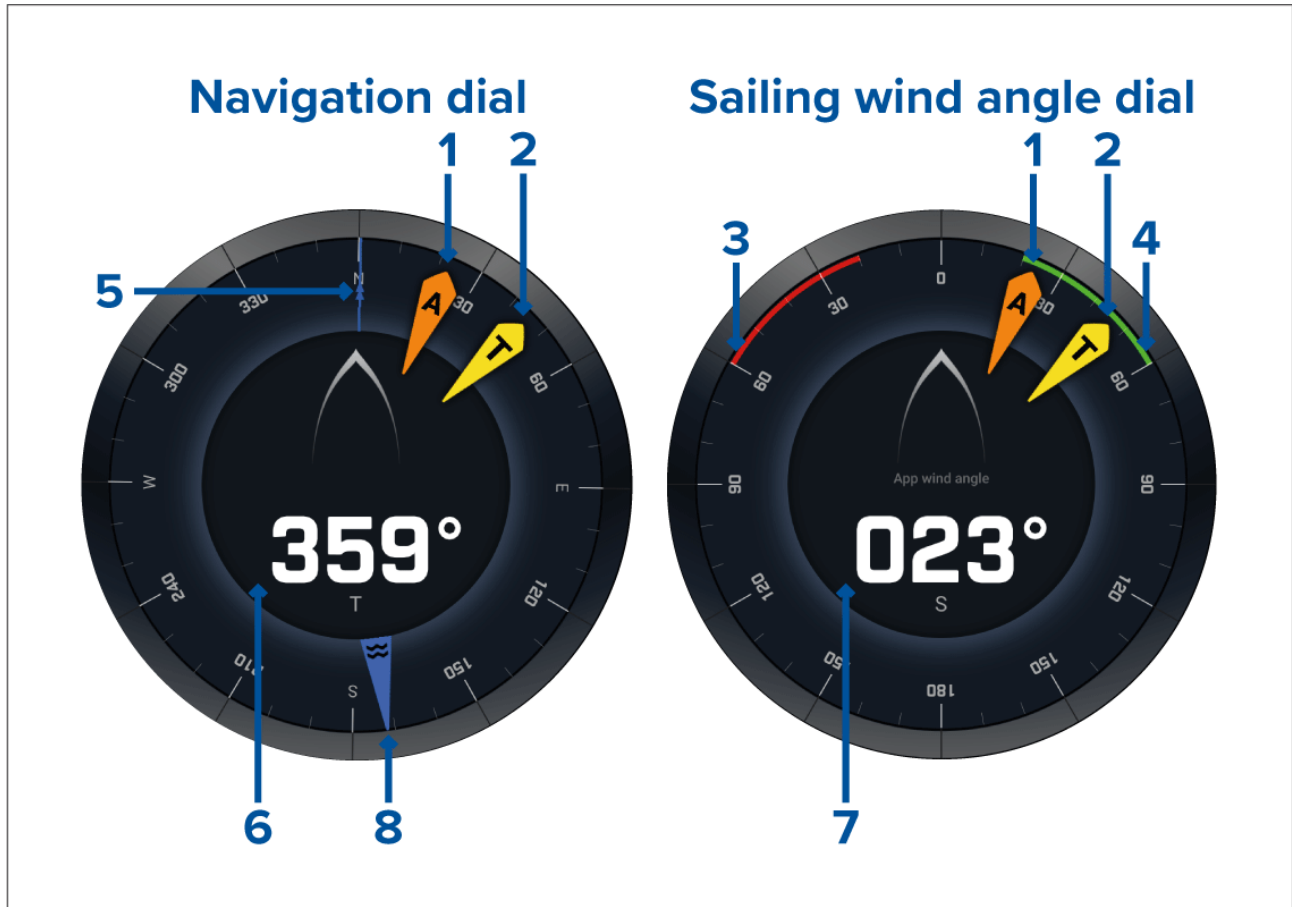

1. Apparent Wind Angle (AWA) indicator
2. True Wind Direction (TWD) indicator

3. Port closed hauled angle
4. Starboard closed hauled angle
5. Compass
6. Heading
7. Apparent Wind Angle (AWA)
8. Tide direction indicator

Sailing dials for laylines

The Sailing page and Navigation page can display an Apparent wind or True wind dial to aid with sailing along laylines.

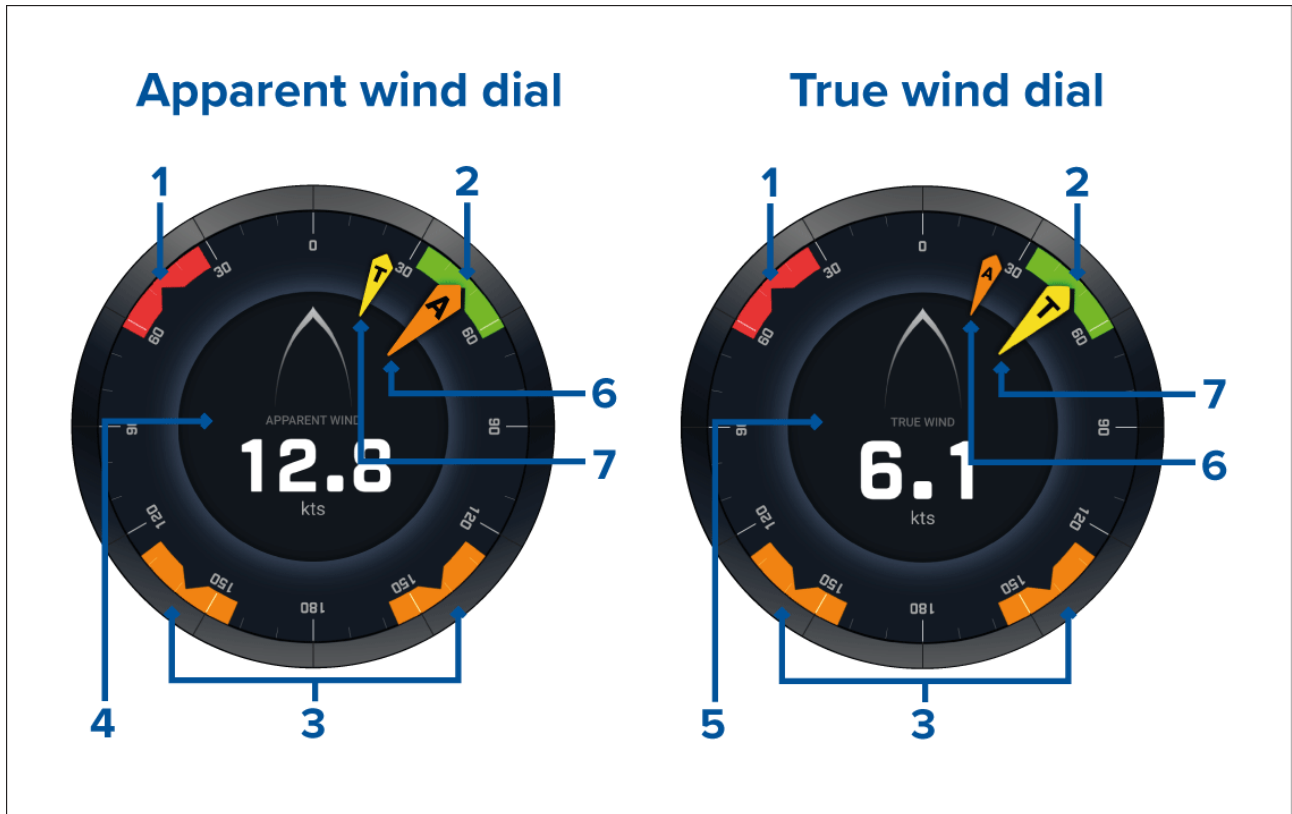

1. Port wind angle target
2. Starboard wind angle target
3. Downwind wind angle target
4. Apparent wind speed (AWS)
5. True wind speed (TWS)
6. Apparent Wind Angle (AWA)
7. True Wind Angle (TWA)



When sailing you may aim the wind angle so it aligns with the centre of the wind angle target to maximise your velocity made good (VMG) when tacking upwind or gybing downwind.

Sailing data items

The default sailing page comes with a selection of data items designed to help with sailing:

- Apparent wind sailing dial
- Distance to tack
- Time to tack

- Sailing distance to waypoint
- Waypoint sailing Time To Go
- Speed through water
- Target speed through water
- Steer to layline
- Polar performance (only active with sailing profile set to polar)
- Rudder bar

It is advised to use the Sailing data items in combination with the Laylines feature available in the **Chart app**. For more information refer to: [8.13 Laylines](#)

Race Start data items

The Race Start page displays a selection of useful data items designed to help you achieve a better racing start.

Note:
Lighthouse software version 3.10 is required.

- Apparent wind sailing dial
- Race Timer (can be used to start, stop and edit the countdown timer)
- Distance to line
- Line bias
- Time to burn
- Time

It is advised to use the Race Start data items in combination with the Laylines feature and the Race Start Line and Race Timer features available in the **Chart app**. For more information refer to:

[8.13 Laylines](#)

[8.14 Race Start Line \(SmartStart\) and Race Timer](#)

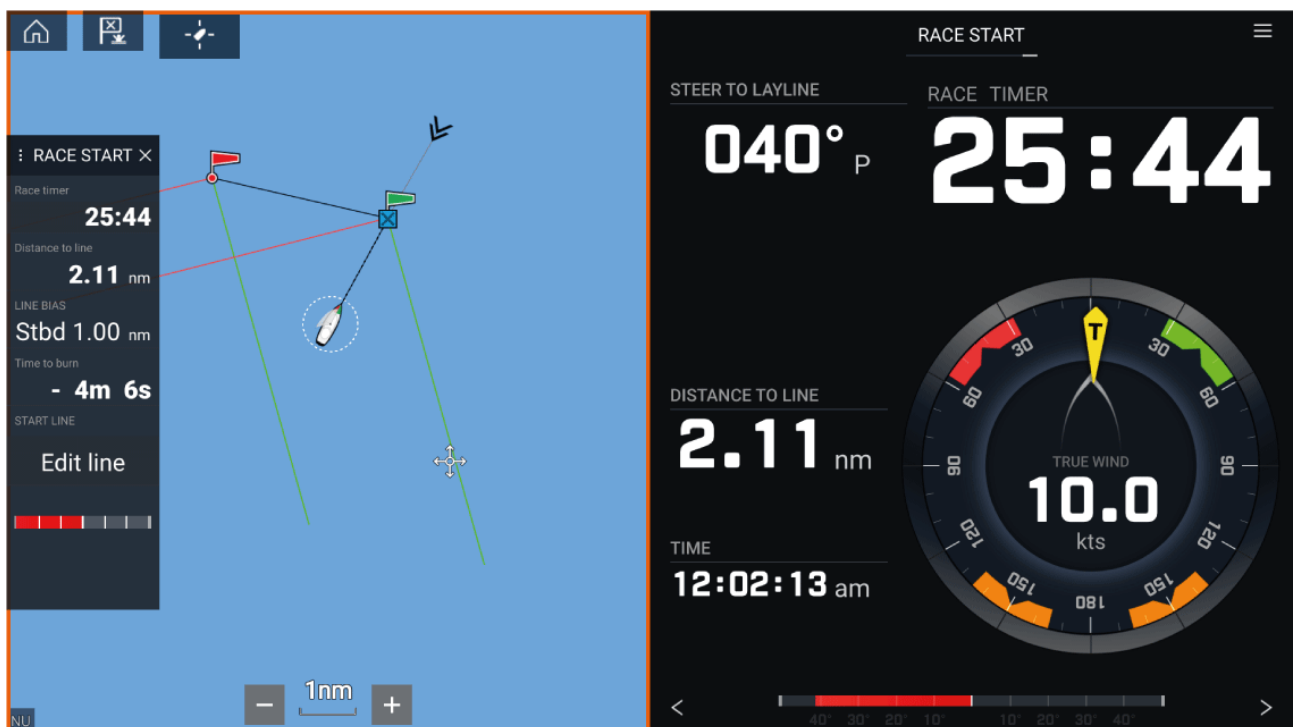

Chapter 14: Yamaha app

Chapter contents

- [14.1 Yamaha engine gateway selection on page 304](#)
- [14.2 Yamaha HDMI overview on page 304](#)
- [14.3 Yamaha app overview on page 304](#)
- [14.4 Customizing Data pages on page 305](#)
- [14.5 Engine page on page 309](#)
- [14.6 Settings on page 314](#)

14.1 Yamaha engine gateway selection

When the MFD is connected to Yamaha engines via a compatible gateway / interface, engine related data can be displayed in the dedicated Yamaha app.

Engine gateway selection is performed as part of the Boat details settings in the initial MFD start up wizard. The selection can also be changed in the Boat details settings tab: **Homescreen > Settings > Boat details > Engine manufacturer.**

- If you have a compatible gateway interface, select **Yamaha** from the Engine manufacturer options.
- If you have a compatible gateway that includes the Yamaha MFD HDMI interface, select **Yamaha HDMI** from the Engine manufacturer options.

Compatible Yamaha gateways

The following gateways are compatible:

- The **Yamaha app** is compatible with Yamaha Command Link and Command Link Pro when connected to the MFD via a Yamaha NMEA 2000 gateway or CL7 gauge.
- The **Yamaha HDMI** app is compatible with Yamaha Command Link and Command Link Pro when connected to the MFD via a Yamaha Helm Master EX 6YG gateway and MFD interface (MFDI).

14.2 Yamaha HDMI overview

The MFD will display the HDMI video input feed from the Yamaha MFDI. Control is achieved using the Yamaha supplied handheld controller.

Please refer to the documentation that was supplied with your Yamaha engine system.

14.3 Yamaha app overview

The **Yamaha app** enables you to view engine system data from a connected Yamaha Command Link or Command Link Pro network.

Note:

- The Yamaha app will only display data when a compatible Yamaha Command Link or Command Link Pro network is connected to the MFD via a Yamaha NMEA 2000 gateway or CL7 gauge.
- The Yamaha app can only be displayed as a Fullscreen app page.
- The Yamaha app is pre-configured with a number of customizable data pages.
- For each instance of the Yamaha app you can select which Data pages you want to use; the Data page selection will persist over a power cycle.

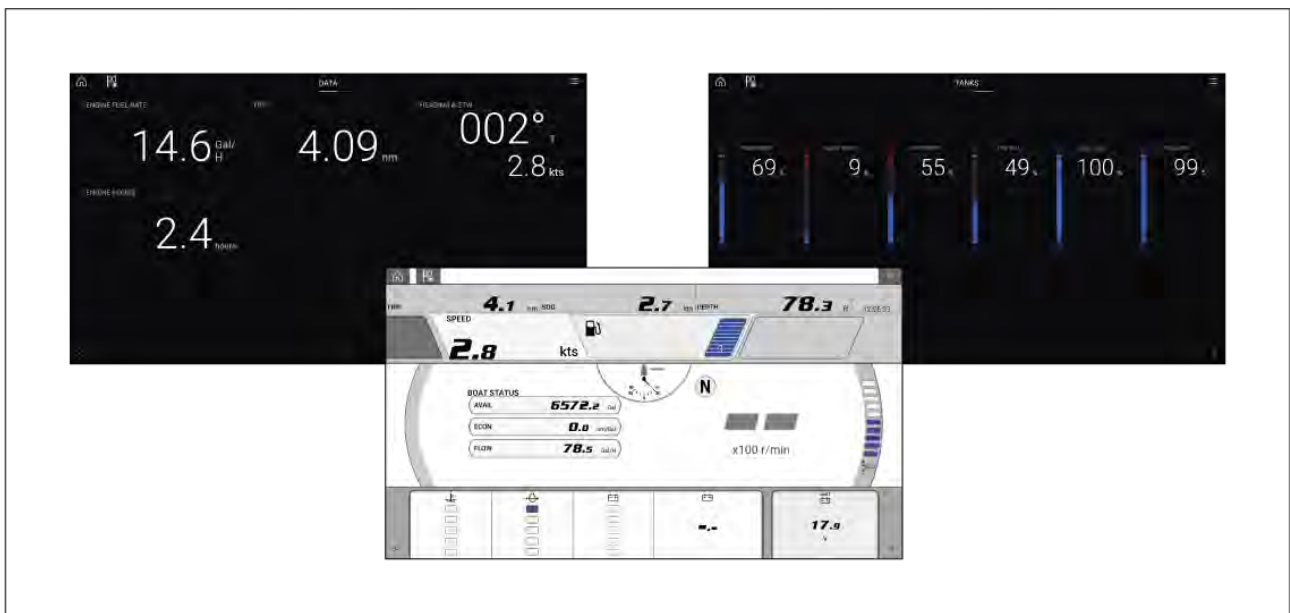

Requirements







The Yamaha app features are enabled (unlocked) when the following requirements are met:

- A compatible Yamaha Command Link or Command Link Pro network is connected to the MFD via a Yamaha NMEA 2000 gateway (6YG-8A2D0-00-00) or CL7 Gauge.
- Your MFD must be running LightHouse 3 version 3.9 or above.

Note:

Do not use a Gateway module (6YG-8A2D0-00-00) and CL7 Gauge together on the same network.

Yamaha app controls

Icon	Description	Function
	Home icon	Takes you to the Homescreen.
	Waypoint / MOB	Place waypoint / activate Man overboard (MOB) alarm.
	Pilot icon	Opens and closes the Pilot Sidebar
	Menu icon	Opens the app menu.
	Left arrow	Displays the previous data page.
	Right arrow	Displays the next data page.

Switching data page

1. Use the **Left arrow** and **Right arrow** buttons, located at the bottom of the screen, to cycle through the available data pages.
2. Alternatively, you can select a specific data page from the Yamaha app menu.

14.4 Customizing Data pages

The Yamaha App contains 3 default data pages: **Engines**, **Data** and **Tanks**. The data items displayed on each page can be changed, hidden or reset.

To customize each page:

1. Select and hold the relevant Data item.
 - i. Alternatively you can select **Customize page** from the app menu: **Menu > Customize page**.
2. Select **Edit**, **Hide** or **Reset** from the Data item pop-over menu.
 - i. **Edit** — you can select the new data item you want to add to the page.
 - ii. **Hide** — removes the data item from the page.
 - iii. **Reset** — reset the value of the selected data item (only available for certain data items).

Available data items

Engine page

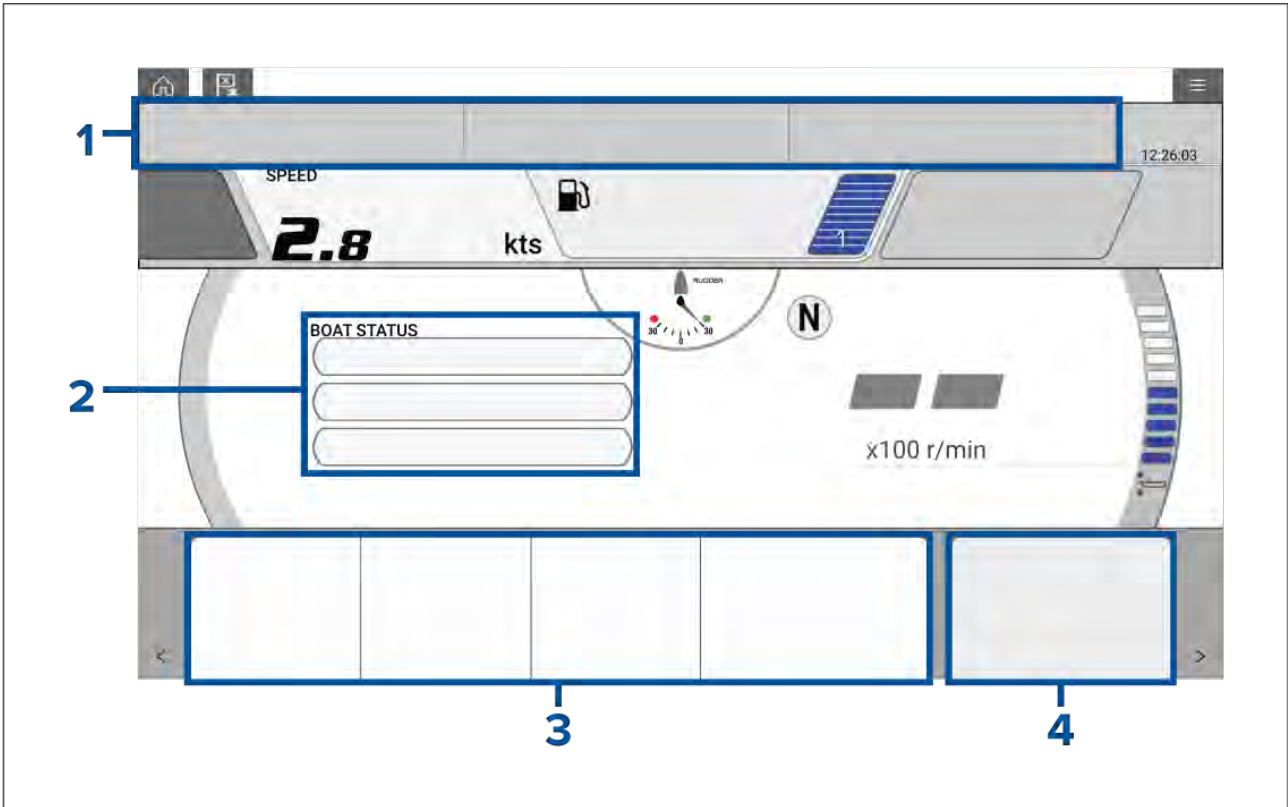

Cell 1 and Cell 2			
Data type	Data item	Data type	Data item
Depth	• Depth	Environment	• Water Temp
Distance	• Trip	GPS	• SOG
Engine	• Engine Trip Hours • Engine Hours	Pilot	• Rudder
Fuel	• Engine economy total • Fuel flow total • Fuel used (trip) • Est. fuel remaining	Speed	• STW
Cell 3		Cell 4	
Data type	Data item	Data type	Data item
Engine	• Coolant Temp • Coolant Pres • Alternator Level • Alternator • Oil Pres	Boat	• Accessory voltage level • Accessory voltage • Supply voltage level • Supply voltage

Data Page



Data type	Data item	Data type	Data item
Battery	<ul style="list-style-type: none"> • TTZ • SOC 	GPS	<ul style="list-style-type: none"> • COG • Avg SOG • Max SOG • SOG • Loran Position • Position • COG SOG
Boat	<ul style="list-style-type: none"> • Mast Rot • Roll • ROT 	Heading	<ul style="list-style-type: none"> • Lock Hdg Err • Tack Heading • Lock Hdg • Heading • Heading & STW
Depth	<ul style="list-style-type: none"> • Max Depth • Min Depth • Depth 	Navigation	<ul style="list-style-type: none"> • VMG to Wpt • BTW & DTW • CMG & VMG to WPT • Compass • BTW • XTE • DTW • CMG • DMG • Wpt ETA • TTP • Target Pos • Loran Target Pos

			<ul style="list-style-type: none"> • Wpt TTG • Wpt • Rte ETA • Next turn angle • Origin target distance • Next waypoint name • BOTW
Distance	<ul style="list-style-type: none"> • Trip season • Trip month • Trip day • Trip manual • Ground Log • Trip • Log 	Pilot	<ul style="list-style-type: none"> • Rudder
Engine	<ul style="list-style-type: none"> • RPM • Engine Trip Hours • Fuel Rate (Avg) • Inst Fuel Economy • Engine Fuel Rate • Engine Hours 	Speed	<ul style="list-style-type: none"> • VMG to Wind • Avg STW • Max STW • STW
Fuel	<ul style="list-style-type: none"> • Engine economy total • Fuel flow total • Time to empty • Distance to empty • Fuel used (season) • Total Trip Fuel • Fuel used (trip) • Est. fuel remaining 	Time	<ul style="list-style-type: none"> • Timer • Sunset Time • Sunrise Time • UTC Time • Local Time • UTC Date • Local Date • Time and Timer
Environment	<ul style="list-style-type: none"> • Drift from ps • Wind Chill (App) • Wind Chill (True) • Dew Point • Max Air Temp • Min Water Temp • Water Temp • Set • Drift • Sunrise/Sunset • Set Drift 	Wind	<ul style="list-style-type: none"> • Max AWA • GWD + Beaufort • TWA & TWS • TWA (CH) & TWS • TWA & VMG to Wind • AWA & AWS • AWA (CH) & AWS • AWA & VMG to Wind • GWS & GWD • AWS • Max AWS • Min AWS • AWA • AWA (CH)

		<ul style="list-style-type: none"> • Cardinal Wind • Min AWA • TWS • Min TWS • Max TWS • TWA • TWA (CH) • Max TWA • Min TWA • TWD • GWS • GWD • Beaufort (wind force scale)
--	--	--

Tanks Page

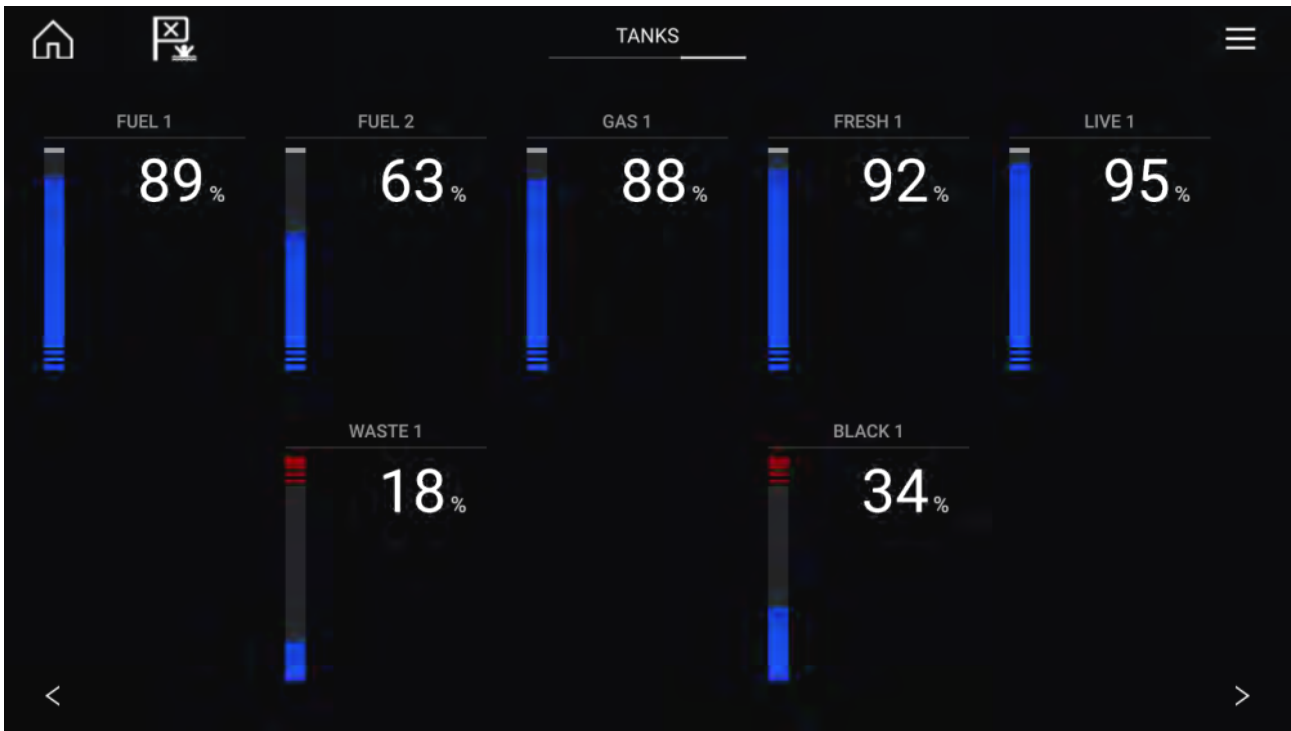

Data type	Data item	Data type	Data item
Boat	<ul style="list-style-type: none"> • Fresh Water • Live Well • Gray Water • Black Water 	Fuel	<ul style="list-style-type: none"> • Total Fuel (vol) • Total Fuel • Fuel level

14.5 Engine page

In addition to the customizable data cells available, the Engine page also displays the following engine and tank data for your vessel:

- Rudder position (single engine only)
- Transmission
- Speed

- Revolutions Per Minute (r/min)
- Engine trim
- Number of fuel tanks and fill level

Troll mode can also be enabled from this page.

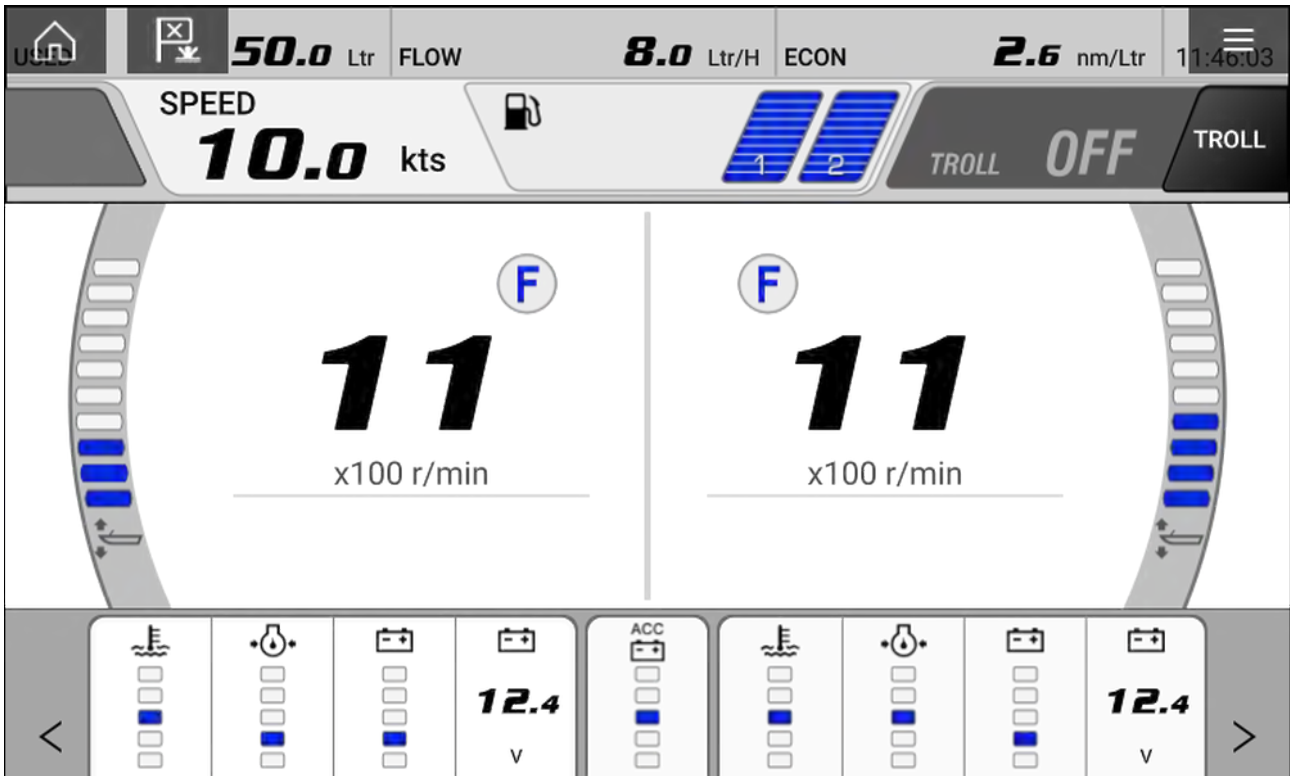

Engines

The number of Yamaha engines connected to your MFD's network determines how the engine page is displayed.

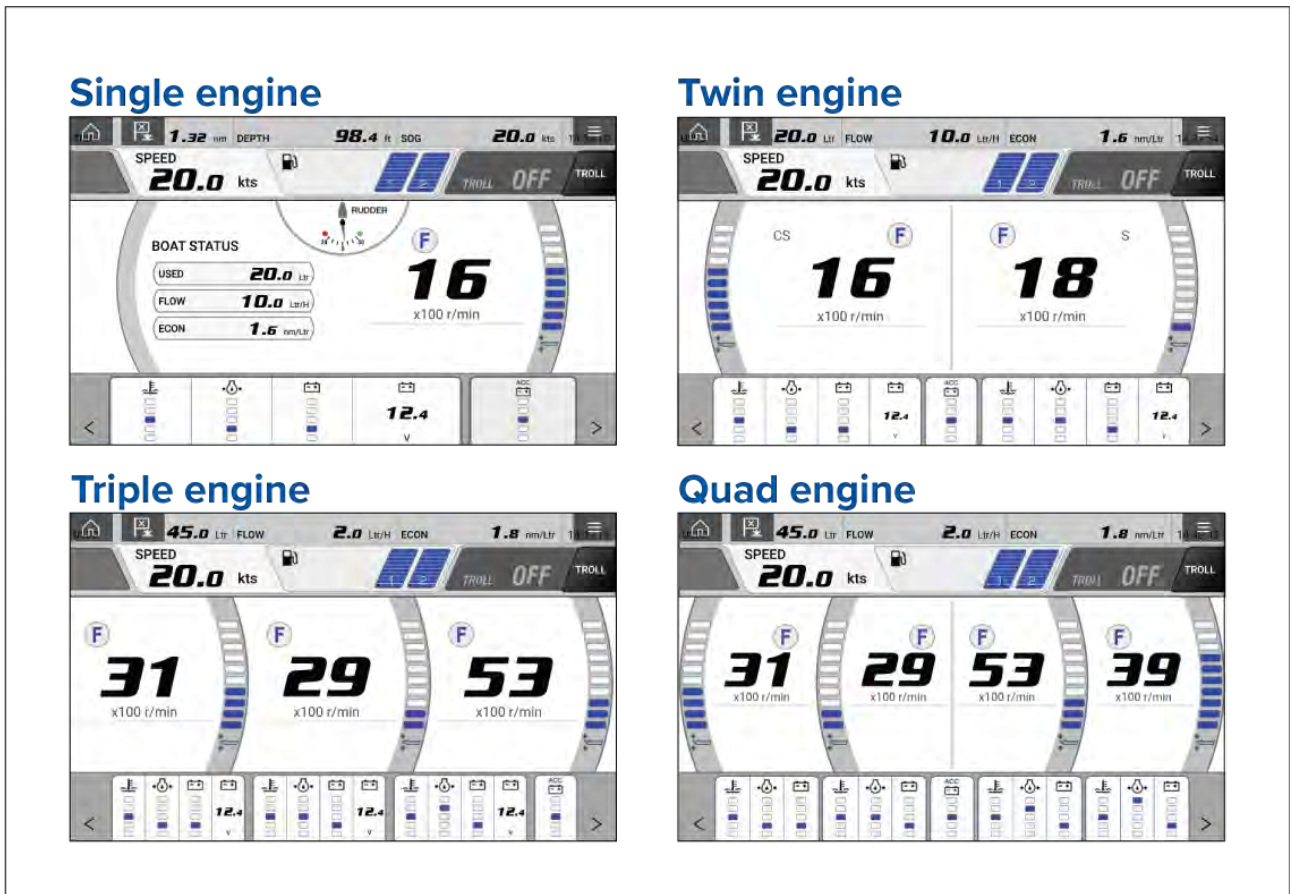

The number of engines and their manufacturer can be set on the **Boat details** page.

Homescreen > Settings > Boat details

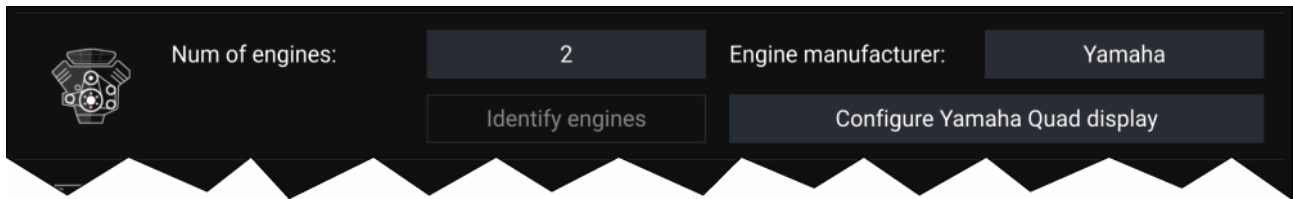

If your vessel is setup using the old quad engine system (2 MFDs for Port and Starboard Engines), you can select which engines are displayed per MFD by selecting **Configure Yamaha Quad display** and choosing **Port side** or **Starboard side**.

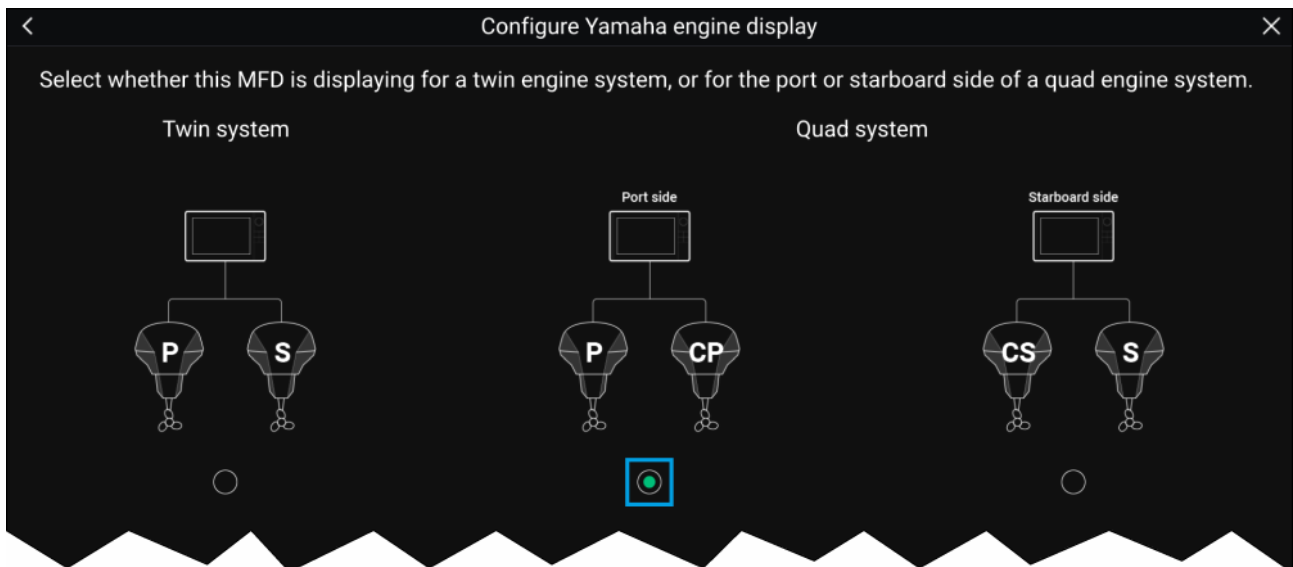

The engine page will update to reflect which engines your MFD is networked to, with Port and Central Port symbols or Starboard and Central Starboard symbols.

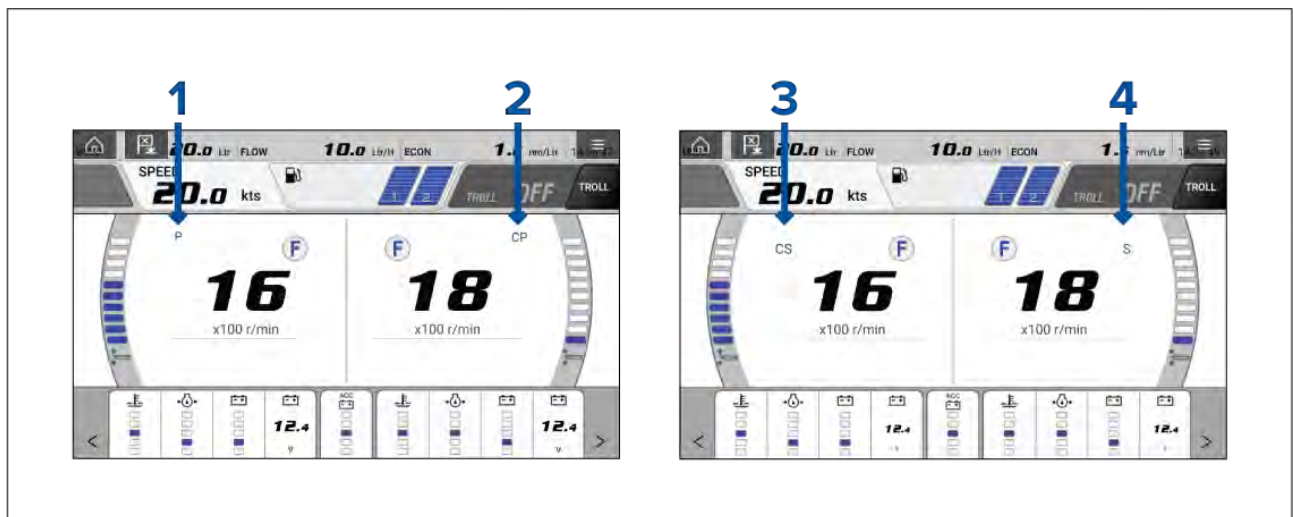

1. Port engine
2. Central Port engine
3. Central Starboard engine
4. Starboard engine

Transmission

The transmission icons indicate which transmission mode your vessel's engine is currently in:

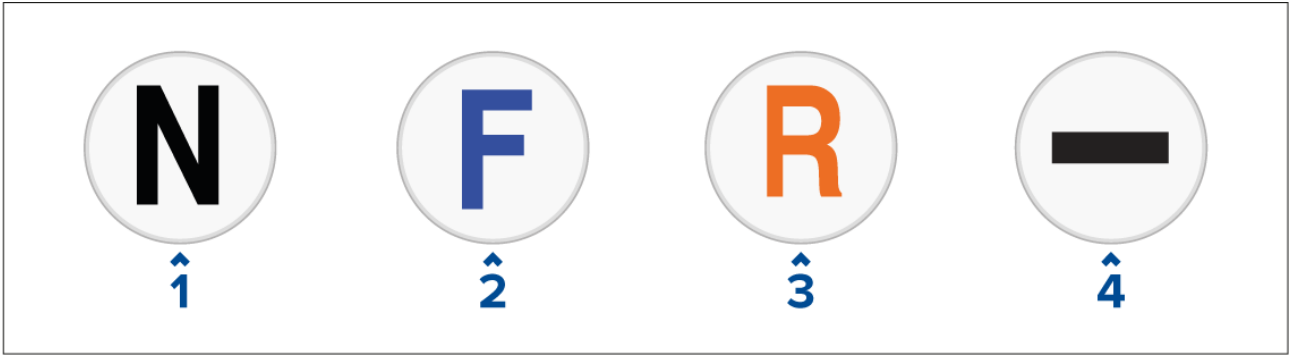

1. Neutral
2. Forward
3. Reverse
4. No transmission data detected

Note:
 If no transmission information is detected from the CAN bus after 3 seconds, it will timeout. Ensure that your engine(s) are compatible and have been connected to your MFD network correctly.

Status and warning indicators

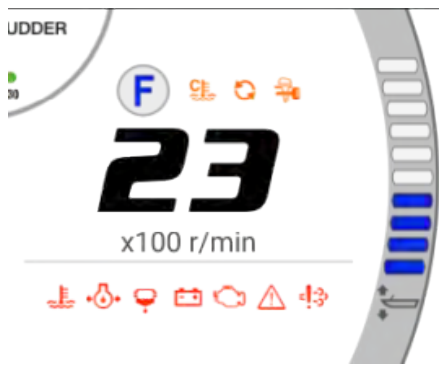

The engine page will display indicators for engine status and warnings.

These status and warning symbols are described below:



1. **Engine warming up status**
2. **Synchronization status**
3. **Immobilizer lock status**

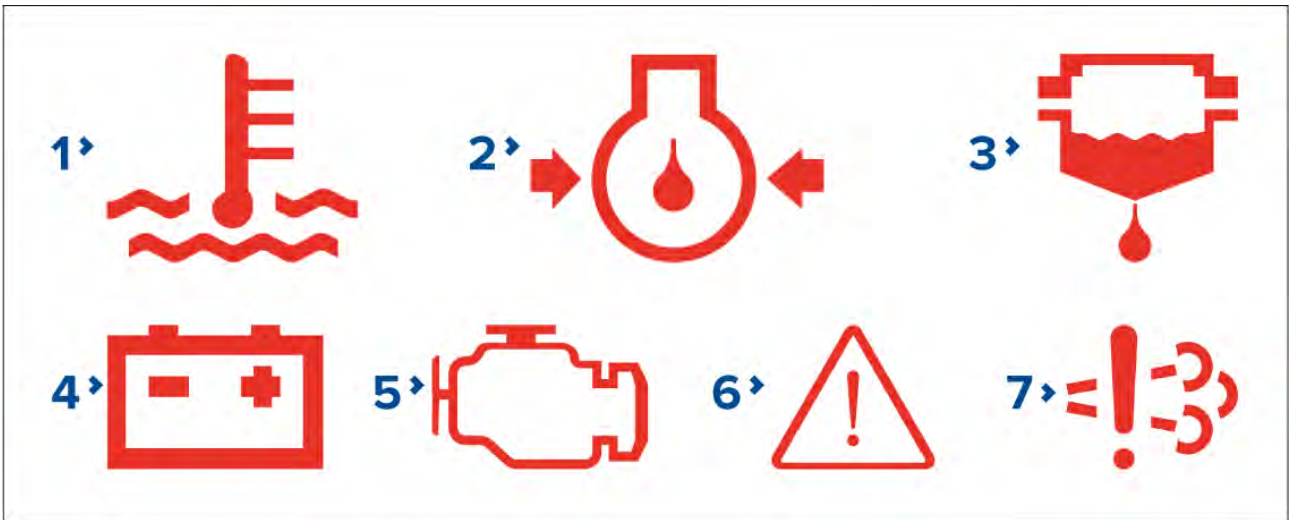

1. **Overheat warning**
2. **Low oil pressure warning**
3. **Water in fuel warning**
4. **Low voltage warning**
5. **Check engine warning**
6. **Steering system warning**
7. **Catalyst warning**

Tanks



The engine page displays the number of tanks aboard your vessel, their type, instance number and fill level.

Note:

- The number of tanks and their type is determined during the installation wizard.
- Tanks require calibration, for more information refer to [Calibrating tanks](#)
- No more than 6 tanks can be displayed on the engine page.
- If there are more than 6 tanks detected on your vessel's network the engine page will display them using the following hierarchy: fuel, fresh water, waste water, gasoline, followed by prioritizing the lowest instance numbers first.

Engine trim



The trim bar displays the trim level of your engine(s), a higher blue bar equates to a higher trim percent. The trim bar will begin to flash if you attempt to set the engine trim beyond 100%.

Troll mode



If your engine supports Troll mode it can be enabled from the engine page. Troll mode is enabled by pressing the Troll mode toggle or by selecting it from the menu.

Note:

- Lower engine RPM and go into idle mode before attempting to activate Troll mode.
- When Troll mode is enabled your RPM gauge will change from x100 r/min to r/min, allowing for more precise control.

14.6 Settings

The settings page can be used to view fault codes, schedule maintenance, and calibrate your engine(s).

Fault codes

The fault codes tab displays all live engine faults detected on the network.

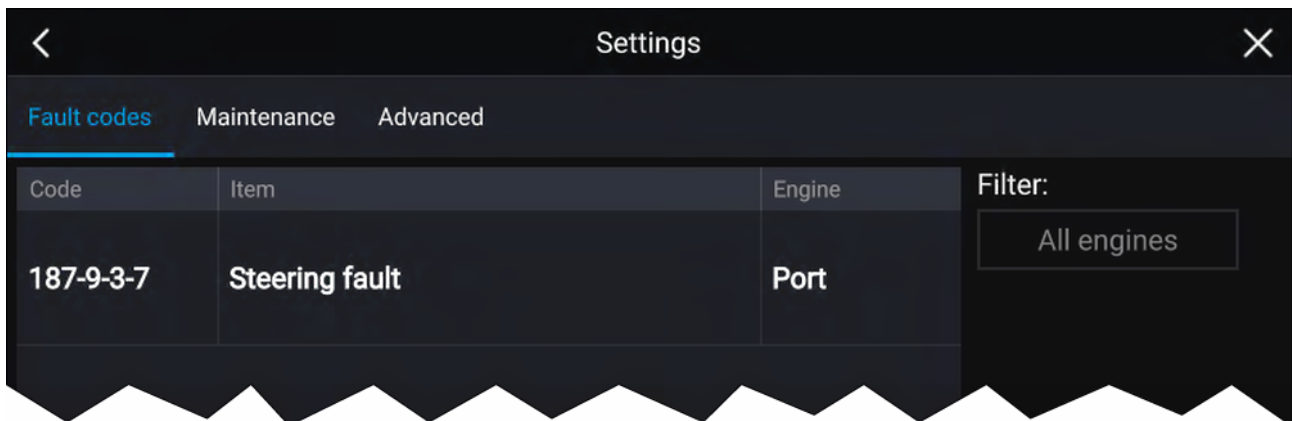

Note:

- The fault codes tab default setting is to display fault codes from all engines.
- You can use the filter option to display fault codes for a specific engine and hide codes for all other engines.

Maintenance

The Maintenance tab displays the amount of time since your Yamaha engine(s) have been serviced.

The amount of hours since last service will automatically accumulate when your Yamaha engine(s) are running. When your engine(s) have been serviced you can long hold the row and select **Reset** from the pop up to return the amount of hours back to 0.

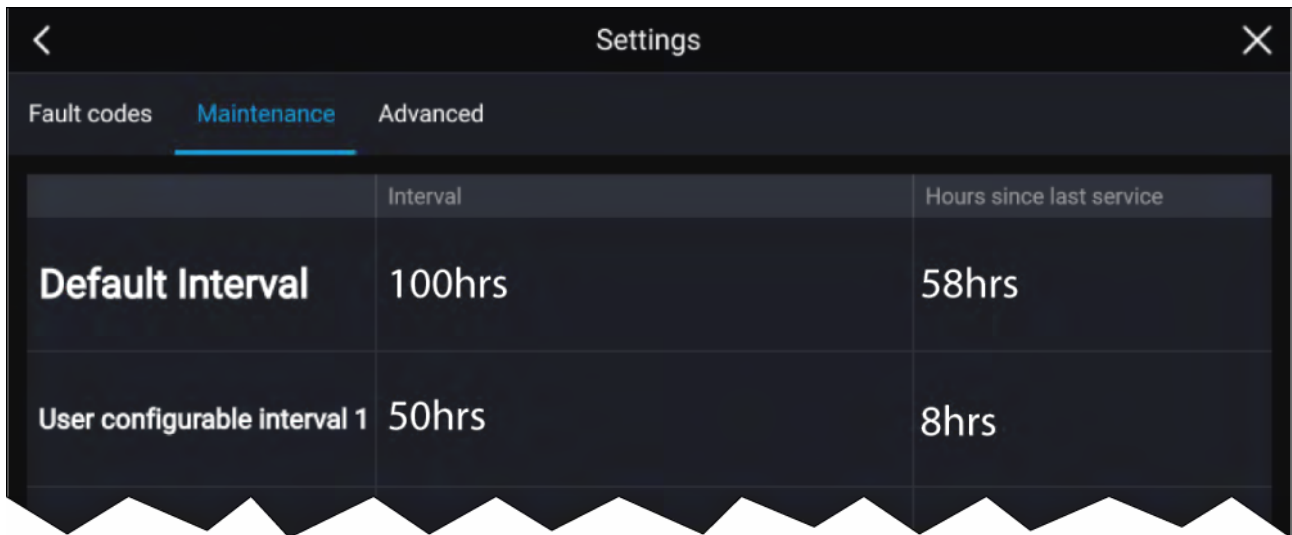

Note:

- A default interval of 100 hours is displayed at the top, this is the recommended maximum amount of time you can use your engine(s) before a service is required.
- Additional user configurable intervals can be customized by long holding each row and choosing the interval length.

Advanced

The Advanced tab is used during the installation and calibration of your Yamaha engine(s). For more information on how to install and calibrate your Yamaha engine(s) refer to Yamaha engine installation manual or Yamaha dealer.

Options:

Gateway reset — System protocol information reset.

Engine instances reset — Engine instances reset. Engine(s) will be reordered based on engine position:

Engine	Port	Central or Central Port	Central Starboard	Starboard
Single Engine	0	-	-	-
Twin Engine	0	-	-	1
Triple Engine	0	1	-	2
Quad Engine	0	1	2	3

All pages reset — All data items on each data page are reset to default.

Fuel flow offset — Set the Fuel flow offset value in accordance with your Fuel flow gauge reading.

Trim Calibration — Calibrate your engine trim by pressing **Set to zero** if any number other than 0 is showing on the Trim Position when engine(s) have stopped.

Chapter 15: Mercury VesselView app

Chapter contents

- [15.1 VesselView app overview on page 318](#)
- [15.2 VesselView Sidebar on page 320](#)

15.1 VesselView app overview

Engine data from Mercury engines can be displayed in the VesselView app when the MFD is connected to the same SeaTalkng® / NMEA 2000 backbone as Mercury engine gateway.

Note:

- A VesselView app page icon will be available on the Homescreen when **Mercury** is selected as the Engine manufacturer during the MFD's initial start up wizard.
- The VesselView app can also be made available by changing the Engine manufacturer setting to **Mercury** and manually adding a VesselView app page icon to the Homescreen.
 - The Engine manufacturer setting is located in the MFD's Boat details settings: **Homescreen > Settings > Boat details > Engine manufacturer:**
 - To create a VesselView app page icon manually refer to: [p.63 – Creating / Customizing an App page](#)

Engine data for up to 4 engines can be displayed. The number of engines data is displayed for is determined by the number of engines specified in the MFD's boat details settings menu: **Homescreen > Settings > Boat details > Num of engine:**

Data for port engine(s) is displayed in the left dial, data for starboard engine(s) is displayed in the right dial. In 3 engine systems the right dial is also used to display data for the Center engine.

In 3 and 4 engine configurations the RPM dial and transmission graphics are dynamic and will switch between engines under different conditions'

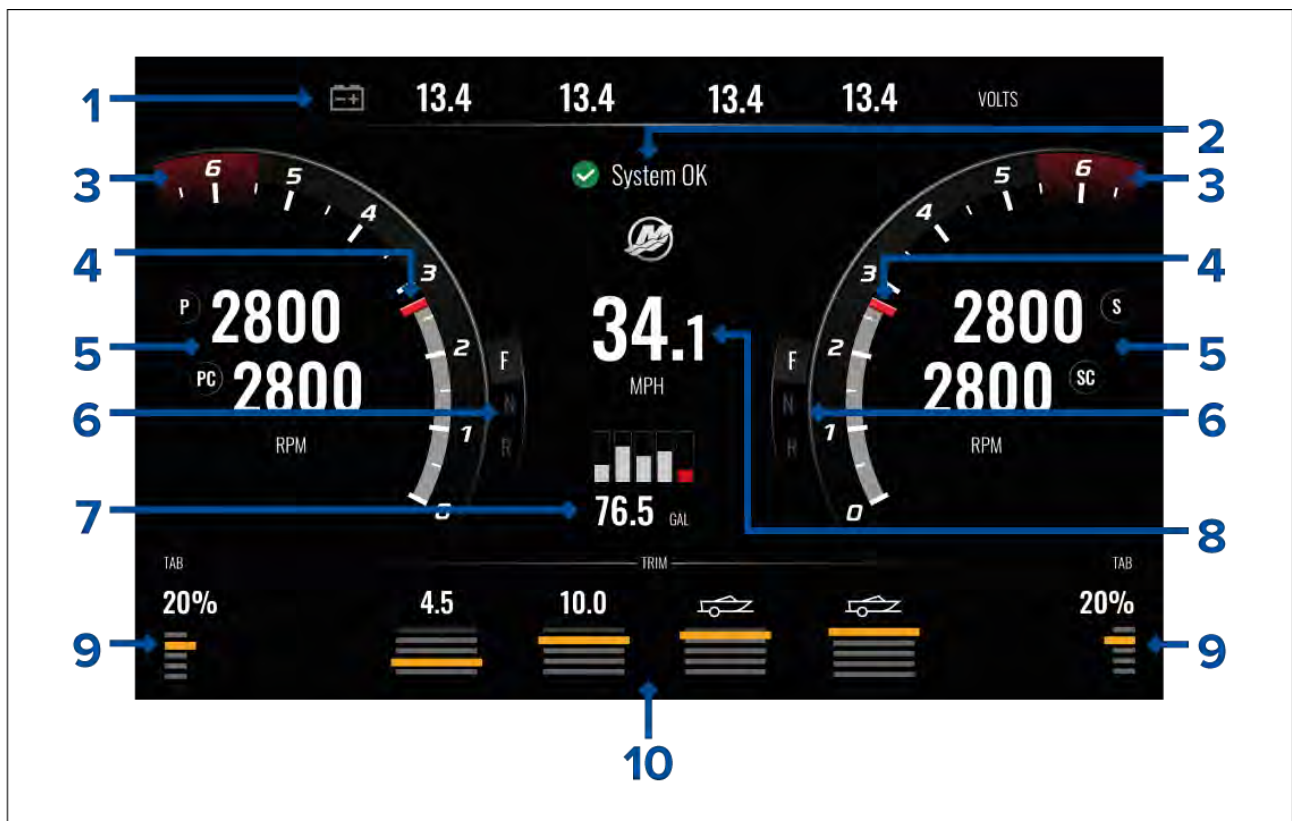

1. Engine battery voltages — The number of batteries displayed is determined by the number of engines i.e.: 1 battery for each engine.
2. System status — Engine status, and start up sequence is displayed.
3. Dynamic engine RPM red zone — The RPM red zone is determined automatically based on engine type. When an engine reaches the RPM red zone the red zone color will change from dark red to bright red.
4. Dynamic engine RPM indicator— Indicates the engine's current RPM.
5. Engine RPM value — Displays current RPM values.
6. Dynamic transmission status — Indicates the current transmission gear.

7. Fuel tanks levels and total fuel — When a tank reaches 20% of its capacity the level indicator will turn red. Upto 5 fuel tanks are supported.
8. Current vessel speed (Speed Through Water).
9. Tab position — Indicates vessel tab position as a percentage with 0% being fully trimmed up (stored) and 100% fully trimmed down.
10. Engine trim — Indicates the engine trim position. Numeric values will be displayed from between 25.0 and 10.0. When the trim number goes above 10.0 the numeric value will be replaced by the boat on trailer icon.

Engine notifications

Engine notifications such as alarms and warnings will be displayed on the MFD screen.

System status

The System status is displayed in the center of the page.

When the system is started a scan is performed after which **System OK** is displayed.

No Communication is displayed if the engines are turned off or engine data cannot be detected.

If the system is restarted after a brief time the system scan is not performed.

Fault code history

The fault codes tab displays live and historical detected engine faults.

Code	Description	Date & Time
256 - 2	Air injector circuit 6 - Wastegate Communication	14/04/2021 08:20
321 - 13	Throttle position sensors A and B for both Port and Starboard - Fuel Injector	14/04/2021 08:20
300 - 8	Throttle position sensor group - Glow Plug	14/04/2021 08:20
256 - 14	Air injector circuit 6 - Emergency Stop	13/04/2021 16:04

By default the Fault codes history tab displays fault codes for all engines. You can use the **Filter** option to display fault codes for a specific engine.

Active and historical engine fault codes can also be viewed from the MFD's Alarm manager: **Homescreen > Alarms** and selecting either **Active** or **History** tab.

15.2 VesselView Sidebar

The VesselView Sidebar is available in all MFD apps and provides quick access to Mercury engine data

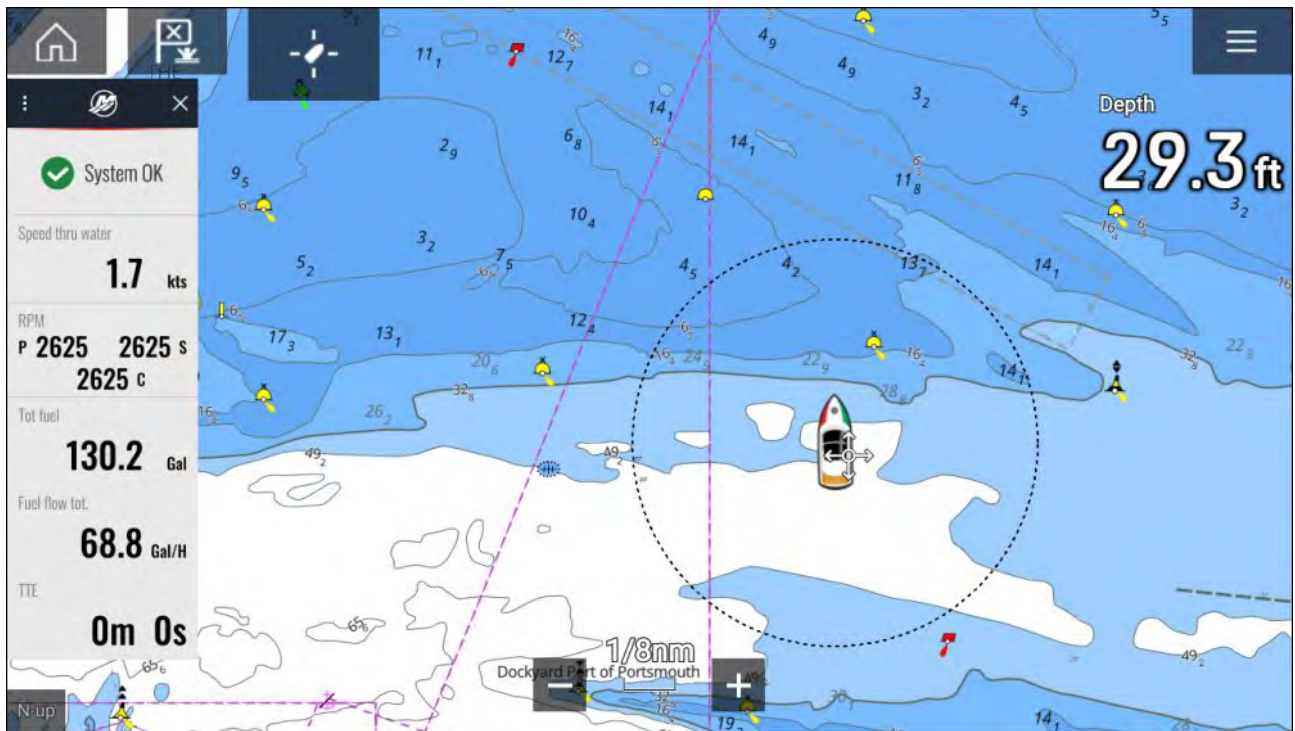

Chapter 16: Video app

Chapter contents

- [16.1 Video app overview on page 322](#)
- [16.2 Opening the Video app on page 324](#)
- [16.3 Video app settings on page 326](#)
- [16.4 Maritime \(M-Series\) camera compatibility on page 329](#)

16.1 Video app overview

Analog video feeds (Axiom™ Pro only) and IP (Internet Protocol) digital video feeds can be viewed, recorded and played back on the MFD using the Video app. Examples of video feeds include: CCTV cameras and Thermal imaging cameras, DVD player etc. It may also be possible to view analog video feeds from other sources using a suitable third party analog-to-IP video converter.

Up to 4 video feeds can be displayed simultaneously when using a splitscreen app page.

Axiom™ Pro MFDs will transmit a connected analog video feed over RayNet to enable the feed to be viewed on networked MFDs.

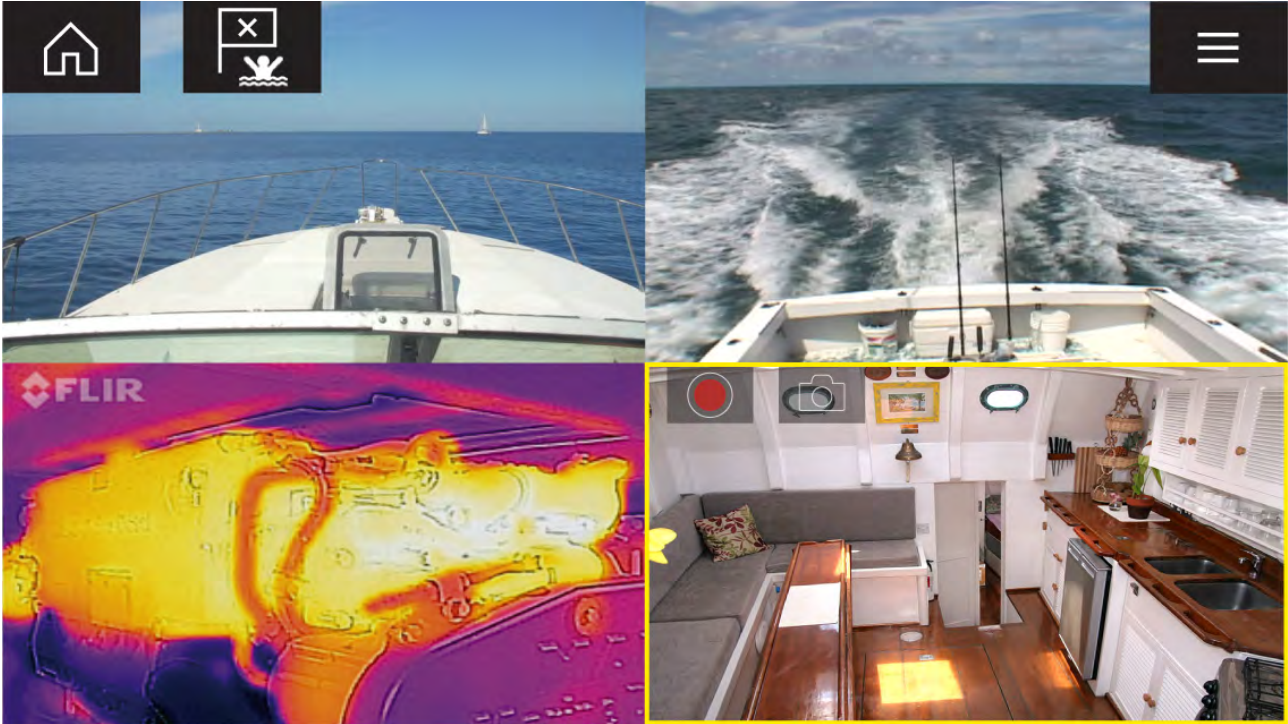

Video app pages

Each Video app instance is unique, this means that once you have selected a feed to display in a Video app page then your feed selection is saved and the same feed will be displayed whenever that app page icon is opened from the Homescreen. If you open the same Video app page from a networked MFD, the same feed will be displayed on each MFD.

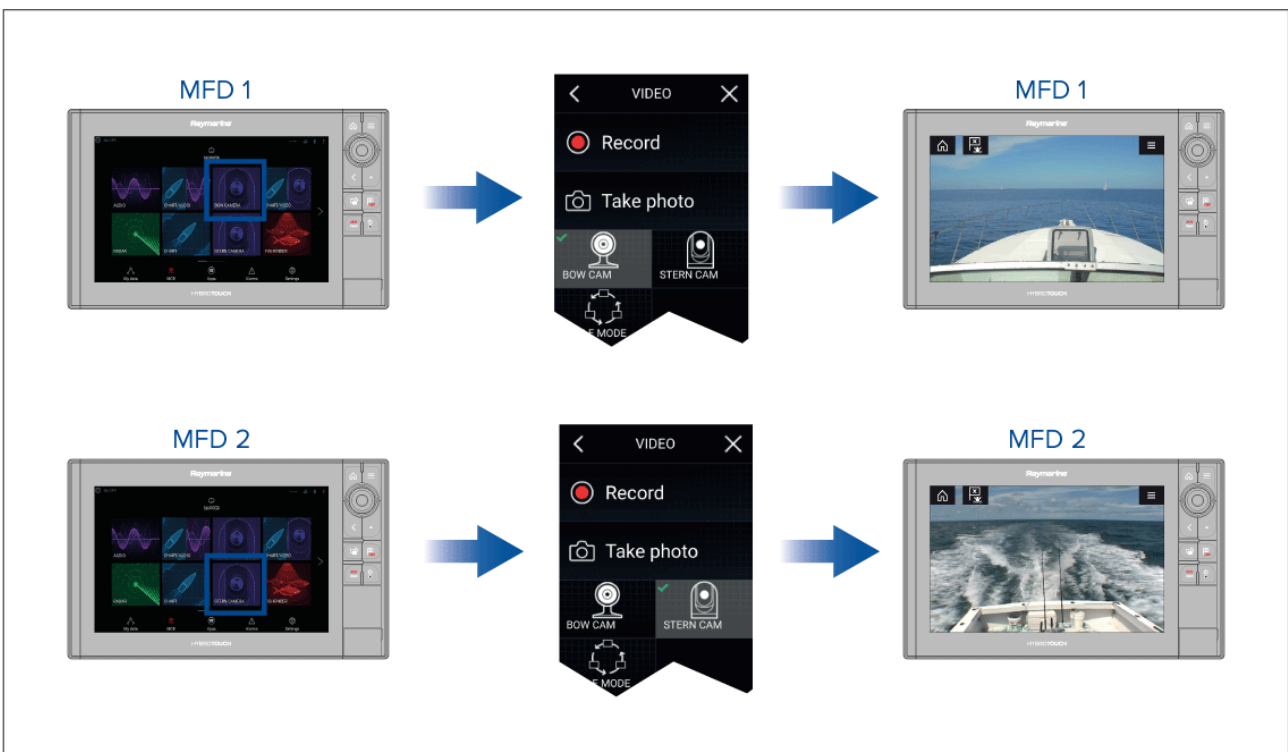

You can create additional Video app pages and assign a different feed to each. This will allow you to view multiple feeds on multiple networked MFDs simultaneously.

For example, if you want to display a different video feed on different networked MFDs, you must first create additional Video app pages.

Note:

When you have multiple Video app page icons on your Homescreen, you may wish to rename each icon to help you easily identify the feeds(s) assigned to each app page. For information on how to rename Homescreen icons, refer to:

[5.4 Creating / Customizing an App page](#)

Renaming video feeds







In multi camera installations you can rename your feed from within the Video app.

From the Video app menu:

1. Select the icon for the camera you want to rename so that its feed is displayed.
2. Goto the Video app's **Settings** menu: **Menu > Settings**.
3. Select the **Camera setup** tab.
4. Select the Camera name field.
5. Use the onscreen keyboard to rename your feed and then select **Save**.

Repeat the above steps for each video feed you want to rename. You can also associate a different icon to your video feed by selecting the **Icon** field.

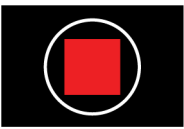
Video app controls

Icon	Description	Function
	Home icon	Takes you to the Homescreen
	Waypoint / MOB	Place waypoint / activate Man overboard (MOB) alarm
	Pilot icon	Opens and closes the Pilot Sidebar
	Menu icon	Opens the app menu
	Record	Start recording (Replaced by Stop icon whilst recording.)
	Stop	Stop recording (Replaced Record icon when not recording.)
	Take photo	Take a photo of what is currently displayed in the active feed.

Pan, Tilt, Zoom (PTZ) camera controls

Extra controls are available for cameras that can pan, tilt or zoom.

Swiping your finger across the screen to pan or tilt the camera.

Use Pinch-to-Zoom to zoom in and out.

When not in use place the camera in the Parked position by selecting **Park camera** from the menu:
Menu > Park camera

Select **Home** from the menu: **Menu > Home** to move the camera to its Home position.

16.2 Opening the Video app

The Video app is opened by selecting an app page icon from the Homescreen which includes the Video app.

Pre-requisites:

1. Ensure your video feed is compatible by checking the latest details available on the Raymarine website against your device's specification. If in doubt please contact an authorized Raymarine dealer for advice.
2. Ensure you have installed your video device in accordance with the documentation that was supplied with your device.

The Video app will open in 1 of 3 states:

Note: If the Video app is opened soon after powering on your system, you may have to wait for the device(s) to finish booting before the video feed is displayed.

Video feed displayed

If your device is powered up and operational then the Device's video feed is displayed.



Camera not yet available

The **'Camera not yet available'** message is displayed if:

- a Video app page is opened before the camera has finished booting up.
- connection to the camera is lost.



CAM200 not yet available. Camera may be booting, or may have connection issues.

If the **'Camera not yet available'** message is displayed for more than 2 minutes, then your MFD cannot connect to your camera. Ensure network and power connections to your camera and MFD are correct and free from damage and then power cycle your system. If the camera feed is still not displayed, refer to your equipment's installation documentation for further troubleshooting information.

No camera detected

The **'No camera detected'** message is displayed if:

- a Video app page is opened for the first time and no compatible camera is connected.
- a Video app page is opened for the first time before the camera has finished booting up.



No camera detected

If the **'No camera detected'** message is displayed for more than 2 minutes, then your MFD cannot connect to your camera. Ensure network and power connections to your camera and MFD are correct and free from damage and then power cycle your system. If the camera feed is still not displayed, refer to your equipment's installation documentation for further troubleshooting information.

Selecting a video feed

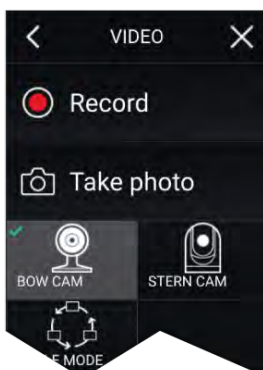

You can change the feed that is displayed in the Video app. From the Video app main menu, select the icon for the camera that you want to display.

Dual streaming

M-Series cameras with dual payloads (visible and thermal camera lens) can stream a visible feed and thermal feed simultaneously.

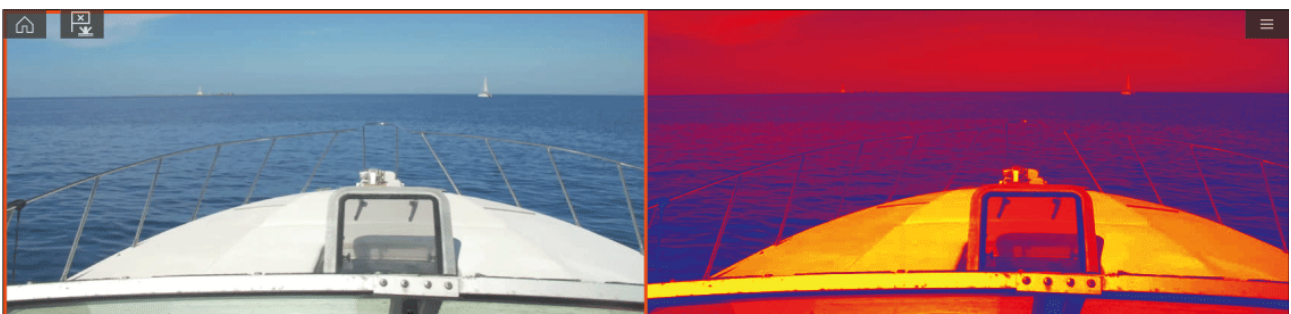

Note:

Dual streaming requires:

- A dual payload M-Series camera: M300, M400 and M500.
- Lighthouse software version 3.11 or later.

Single MFD

Activate dual video streaming on a single MFD.

1. From the **Homescreen**, create a custom combo app that comprises of at least 2 **Video apps**. For more information on creating and customizing LightHouse apps, refer to: [p.63 – Creating / Customizing an App page](#)
2. Open the combo app and select one of the Video app instances.
3. Select the dual payload camera and select the stream you want to display (visible or thermal):

Combo app > Menu > Settings > Image Tab > Active feed > Visible / Thermal

4. Repeat steps 2 and 3 for the other app instance and video stream.

Dual MFDs

Activate dual video streaming on at least 2 MFDs connected on the same network.

Note:

Make sure your MFDs are both correctly connected on the same network as the dual payload camera.

1. Open the **Video app** on one of the MFDs.
2. Select the dual payload camera and select the stream you want to display (visible or thermal):

Video app > Menu > Settings > Image Tab > Active feed > Visible / Thermal

3. Repeat steps 1 and 2 for the other MFD and video stream.

16.3 Video app settings

The Settings menu provides access to the Video app's features and functions. The options available in the Settings menu are dependent on your system configuration and connected devices.

Image tab

Settings	Description	Options
Active feed	On cameras with more than 1 payload you can select which feed to display in the Video app.	<ul style="list-style-type: none"> • Thermal • Visible
Blending Mode	<p>On cameras with more than 1 payload you can blend the two feeds together, displaying an overlap of daylight stream on top of thermal image, providing enhanced detail.</p> <ul style="list-style-type: none"> • CTV - Colored daylight image blended with the thermal feed. • MSX - Black and white daylight image detects and sharpens the edges of objects shown on the thermal feed. 	<ul style="list-style-type: none"> • Off • CTV • MSX
Blending Level	Set the percentage of the blend between both camera feeds for CTV or MSX blending.	<ul style="list-style-type: none"> • 0% to 100%

Settings	Description	Options
Light	For cameras that include a light this setting switches the camera's light on and off as well as flashing mode and SOS mode.	<ul style="list-style-type: none"> • On • Off • Flash • SOS
Palette	Various color palettes are available to suit different conditions or your personal preference.	<ul style="list-style-type: none"> • WhiteHot • BlackHot • RedHot • RedHot Inverse • Fusion • Firelce • Firelce Inverse
Scene	Scene presets that have been optimized for different running conditions.	<ul style="list-style-type: none"> • Day • Night • Docking • High contrast
Auto focus	The camera will focus the image.	<ul style="list-style-type: none"> • Activate
Low light mode	Visible cameras supporting low light mode can set this during low light conditions.	<ul style="list-style-type: none"> • On • Off • Auto
Wide Dynamic Range	Improves the viewable range of darkness to lightness of the image.	<ul style="list-style-type: none"> • Disable • Enable
Contrast Enhancement	Adjusts the brightness and contrast of the image to make dark and bright sections more distinguishable.	<ul style="list-style-type: none"> • Disable • Enable
Electronic stabilization	Stabilizes the image to reduce blurring caused by camera shake.	<ul style="list-style-type: none"> • Disable • Enable
Digital Zoom	Zooms the camera feed to maximum.	<ul style="list-style-type: none"> • Disable • Enable
Roll correction <i>(Requires AR200)</i>	Accounts for boat tilting and will adjust video feed accordingly. Video feed horizon will be parallel with the actual horizon.	<ul style="list-style-type: none"> • Disable • Enable

Camera setup tab

Settings	Description	Options
Heater	Enables and disables the camera's built-in heater used to de-mist the camera lens.	<ul style="list-style-type: none"> • Disable • Enable
Zoom Lock	Synchronize zoom level between visible and thermal camera feeds.	<ul style="list-style-type: none"> • Disable • Enable
Mirrored view	Flips the camera image to provide a mirror image, suitable for rear view installations.	<ul style="list-style-type: none"> • Disable • Enable
Camera name	Change your camera name.	<ul style="list-style-type: none"> • Displays the onscreen keyboard.
Icon	Select the icon to be used for the camera.	<ul style="list-style-type: none"> • List of icons.

Settings	Description	Options
Flip image vertical	Flips the camera image upside down, suitable for Ball-down installations.	<ul style="list-style-type: none"> • Disable • Enable
UI language	Select the language of the user interface.	<ul style="list-style-type: none"> • List of languages.
On-screen icons	Sets the level for the camera's built-in onscreen icons	<ul style="list-style-type: none"> • None • Minimal • All
Save default settings	Save the current camera settings as the default.	<ul style="list-style-type: none"> • Save
Restore default settings	Restore the camera settings to default.	<ul style="list-style-type: none"> • Run default restore
Self-tests and calibration	Offers a series of tests and calibration options for your camera.	<ul style="list-style-type: none"> • Pan/tilt test • Reset IR lens • Flat Field Correction • Set elevation reference • Set forward position
Restore factory settings	Restore camera settings to factory default.	<ul style="list-style-type: none"> • Run factory restore

Photo & Video recording tab

Settings	Description	Options
Save files to:	Determines the save location for photos and video recordings. <hr/> Note: External SD 1 and USB Media are available when using the RCR-SDUSB Accessory.	<ul style="list-style-type: none"> • SD 1 • External SD 1 USB Media

ClearCruise tab (Augmented Reality) (Requires AR200)

Settings	Description	Options
Augmented Reality	Enables / disables Augmented Reality and Augmented reality settings.	<ul style="list-style-type: none"> • Disable • Enable
AIS labels	Display other vessels as flags (requires AIS).	<ul style="list-style-type: none"> • Disable • Enable
Hide static targets	Hide AIS targets travelling under 2 knots (requires AIS).	<ul style="list-style-type: none"> • Disable • Enable
Waypoints	Display Waypoints as flags.	<ul style="list-style-type: none"> • Disable • Enable
Chart objects	Display Chart objects as flags (requires compatible charts).	<ul style="list-style-type: none"> • Disable • Enable
Cartography source	Select the cartography ClearCruise displays data from (requires compatible charts).	<ul style="list-style-type: none"> • Cartography source options
Compass	Display the Compass bar.	<ul style="list-style-type: none"> • Disable • Enable
Range limit	Set the maximum range flags will automatically be displayed from.	<ul style="list-style-type: none"> • 1/8nm to 13nm

ClearCruise tab (Object Detection) / (Video Analytics)

Settings	Description	Options
Highlight detected objects	Uses proprietary ClearCruise™ technology to highlight and track objects detected in the water.	<ul style="list-style-type: none"> • Disable • Enable
Beep on detection	When enabled, the MFD will audibly beep when an object is detected.	<ul style="list-style-type: none"> • Disable • Enable
Display estimated range	When enabled, the MFD will display an estimated range for highlighted objects (objects must be closer than 300 ft).	<ul style="list-style-type: none"> • Disable • Enable

Camera motion tab

Settings	Description	Options
Camera height above the waterline	To ensure correct alignment of the camera for tracking purposes the height the camera has been installed at, above the waterline, must be set.	<ul style="list-style-type: none"> • 0ft to 99ft
Set forward position	Adjust the Forward position of your camera	Displays the forward alignment picture
Man overboard	Enables and disables automatic tracking of a MOB alarm. The most recent target is tracked.	<ul style="list-style-type: none"> • Disable • Enable
Dangerous AIS targets	Enables and disables automatic tracking of Dangerous AIS targets. The most recent target is tracked.	<ul style="list-style-type: none"> • Disable • Enable
Dangerous MARPA targets	Enables and disables automatic tracking of Dangerous Radar targets. The most recent target is tracked.	<ul style="list-style-type: none"> • Disable • Enable
Enable scan	Enables and disables Surveillance mode. Surveillance mode pans the camera left to right continuously to the specified speed	<ul style="list-style-type: none"> • Disable • Enable
Scan width	Determines how far the camera pans from left to right when in Surveillance mode.	<ul style="list-style-type: none"> • Narrow • Medium • Wide
Scan speed	Determines the speed at which the camera pans from left to right when in Surveillance mode.	<ul style="list-style-type: none"> • Slow • Medium • Fast

Page settings

Settings	Description	Options
Edit data overlays	Add data overlays to video feed.	<ul style="list-style-type: none"> • List of data overlays

16.4 Maritime (M-Series) camera compatibility

Support for the various video features and settings, as per each M-Series camera variant.

For an explanation of the settings listed in the following table, refer to: [p.326 – Video app settings](#)

Not applicable to product	—
Applicable to product	

Applicable to product (M200 only)		(M200 only)		
Applicable to dual payload M300 variants only		***		
IMAGE TAB				
Setting	M100/M200	M300***	M400	M500
Active feed <ul style="list-style-type: none"> Thermal Visible 	—			
Blending mode <ul style="list-style-type: none"> Off CTV MSX 	—		—	—
Blending level <ul style="list-style-type: none"> 0% to 100% 			—	—
Light <ul style="list-style-type: none"> Off On Flash SOS 	—	—		
Palette (<i>Thermal feed</i>) <ul style="list-style-type: none"> WhiteHot BlackHot RedHot RedHot Inverse Fusion Fusion Inverse Firelce Firelce Inverse 				
Scene (<i>Thermal feed</i>) <ul style="list-style-type: none"> Day Night Docking High Contrast 				
Auto focus (<i>Visible feed</i>) <ul style="list-style-type: none"> Activate 	—	—		
Low light mode (<i>Visible feed</i>) <ul style="list-style-type: none"> Off On Auto 	—			
Wide dynamic range (<i>Visible feed</i>) <ul style="list-style-type: none"> Disable Enable 	—			

IMAGE TAB				
Contrast enhancement (<i>Visible feed</i>) <ul style="list-style-type: none"> • Disable • Enable 	—			
Electronic stabilization (<i>Visible feed</i>) <ul style="list-style-type: none"> • Disable • Enable 	—	—	—	
Digital Zoom <ul style="list-style-type: none"> • Disable • Enable 				
Roll correction (<i>Requires AR200</i>) <ul style="list-style-type: none"> • Disable • Enable 			—	—

CAMERA SETUP TAB				
Setting	M100/M200	M300***	M400	M500
Heater <ul style="list-style-type: none"> • Disable • Enable 				
Zoom lock <ul style="list-style-type: none"> • Disable • Enable 	—			
Mirrored view <ul style="list-style-type: none"> • Disable • Enable 				
Camera name <ul style="list-style-type: none"> • Onscreen keyboard 				
Icon <ul style="list-style-type: none"> • List of camera icons 				
Flip image vertical <ul style="list-style-type: none"> • Disable • Enable 				
UI language <ul style="list-style-type: none"> • List of available languages 	—			
On-screen icons <ul style="list-style-type: none"> • None • Minimal • All 	—			
Save default settings <ul style="list-style-type: none"> • Save 	—			
Restore default settings <ul style="list-style-type: none"> • Run default restore 	—			

CAMERA SETUP TAB				
Self-tests and calibration				
Pan/tilt test		—		
Set elevation reference				
Set forward position				
Spotlight test	—	—		
Self-tests and calibration (<i>Thermal feed</i>)				
IR test pattern	—	—		
Reset IR lens		—		
Flat field correction				
Restore factory settings				
• Run factory restore				

PHOTO & VIDEO RECORDING				
Setting	M100/M200	M300***	M400	M500
Save files to				
• List of connected SD cards				

CLEARCRUISE™				
Setting	M100/M200	M300***	M400	M500
ClearCruise™ Augmented Reality (Requires AR200)			—	—
Augmented Reality			—	—
• Disable				
• Enable				
AIS targets			—	—
• Disable				
• Enable				
Hide static targets			—	—
• Disable				
• Enable				
Waypoints			—	—
• Disable				
• Enable				
Chart objects			—	—
• Disable				
• Enable				
Cartography source			—	—
• Disable				
• Enable				
Compass			—	—
• Disable				
• Enable				

CLEARCRUISE™				
Range limit <ul style="list-style-type: none"> • Disable • Enable 			—	—
ClearCruise™ Object Detection (Video Analytics)			—	—
Highlight detected objects <ul style="list-style-type: none"> • Disable • Enable 		—	—	—
Beep on detection <ul style="list-style-type: none"> • Disable • Enable 		—	—	—
Display estimated range <ul style="list-style-type: none"> • Disable • Enable 		—	—	—

CAMERA MOTION				
Setting	M100/M200	M300***	M400	M500
Camera height above waterline <ul style="list-style-type: none"> • Adjust value 				
Forward position <ul style="list-style-type: none"> • Adjust position and Save 	<i>(M200 only)</i>			
Man overboard <ul style="list-style-type: none"> • Disable • Enable 	<i>(M200 only)</i>			
Dangerous AIS target <ul style="list-style-type: none"> • Disable • Enable 	<i>(M200 only)</i>			
Dangerous MARPA target <ul style="list-style-type: none"> • Disable • Enable 	<i>(M200 only)</i>			
Vertical stabilization <ul style="list-style-type: none"> • Disable • Enable 	<i>(M200 only)</i>			
Horizontal stabilization <ul style="list-style-type: none"> • Disable • Enable 	<i>(M200 only)</i>			
Enable scan <ul style="list-style-type: none"> • Disable • Enable 	<i>(M200 only)</i>			

CAMERA MOTION				
Scan width <ul style="list-style-type: none"> • Disable • Enable 	<i>(M200 only)</i>			
Scan speed <ul style="list-style-type: none"> • Disable • Enable 	<i>(M200 only)</i>			
PAGE SETTINGS				
Setting	M100/M200	M300***	M400	M500
Edit data overlays <ul style="list-style-type: none"> • List of data overlays 				

Chapter 17: ClearCruise (Object Detection / Video Analytics, and Augmented Reality)

Chapter contents

- [17.1 ClearCruise™ features on page 336](#)
- [17.2 Camera setup on page 337](#)
- [17.3 AR200 setup for Augmented Reality on page 341](#)
- [17.4 ClearCruise™ Object Detection \(Video Analytics\) overview on page 341](#)
- [17.5 Augmented Reality \(AR\) overview on page 343](#)
- [17.6 Augmented Reality flags on page 344](#)
- [17.7 ClearCruise settings \(Augmented Reality\) on page 348](#)
- [17.8 Roll correction on page 350](#)
- [17.9 AR200 Calibration \(Linearization\) on page 352](#)

17.1 ClearCruise™ features

ClearCruise™ features are designed for enhancing situational awareness and aiding navigation.

ClearCruise™ technology provides 2 separate features, which are described in more detail throughout this chapter:

- Object Detection (Video Analytics)
- Augmented Reality (AR)

Object Detection

Object Detection (Video Analytics) is a feature available for M100, M200, and M300 Series thermal cameras. Intelligent thermal analytics technology provides audible and visual alerts when “non-water” objects are identified in the scene. Vessels, obstacles, and navigation markers can all be automatically identified by the camera without the need for Chart or Radar data.

Required components for Object Detection

- MFD: Axiom / Axiom Pro / Axiom XL, or eS Series / gS Series running LightHouse 3.
- Thermal Camera (M100, M200, or M300 Series), **running the latest available software version.**
- LightHouse™ software (v3.0 or later)

Note: Visit www.raymarine.com/software to download the latest software for your MFD and camera.

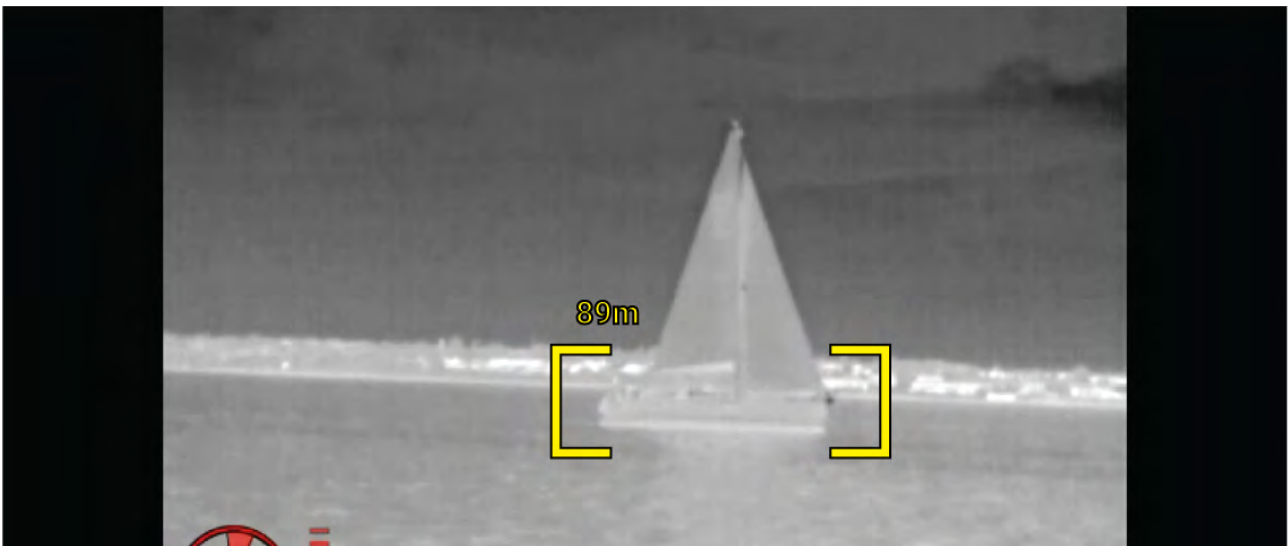

Note: Weather conditions can cause the target's temperature, luminance, contrast or chrominance to be below a detectable range in relation to the background image. Therefore, the effectiveness of the ClearCruise Object Detection (Video Analytics) feature for distinguishing targets and non-targets is dependent on optimal scene conditions. It is recommended:

- The visible image is adjusted to contain good color, brightness and contrast;
- Accuracy can be improved by excluding irrelevant regions such as sun glare.

Augmented Reality

The **Augmented Reality** feature places layers of digital information directly over the top of the Video app's video feed. Data from the Chart app is used to generate informative text and images (flags) on the Video app. When calibrated correctly, ClearCruise™ Augmented Reality accurately overlays automatically-updating flags on the Video app so they overlap real-life objects.

Required components for Augmented Reality (IP cameras)

- MFD (Axiom, Axiom Pro or Axiom XL)
- AR200 Augmented Reality Sensor
- IP camera (CAM210IP or CAM220IP)
- LightHouse™ software (v3.7 or later)

Required components for Augmented Reality (M-Series cameras)

- MFD (Axiom, Axiom Pro or Axiom XL)
- AR200 Augmented Reality Sensor

- M-Series camera (M100, M200 and M300 Series)
- M100 / M200-Series cameras require LightHouse™ software version 3.9 or later.
- M300-Series cameras require LightHouse™ software version 3.10.71 or later.

Important:

Cameras utilizing ClearCruise™ Augmented Reality are subject to an unstable image on rough waters.



Note: ClearCruise's performance is dependent on environmental conditions and is not a replacement for maintaining a visual watch.

17.2 Camera setup

Before using the Augmented Reality features, it's important to correctly install and setup your compatible camera.

Refer to your camera's installation manual to determine the correct physical installation and connections for using the camera as part of an Augmented Reality system.

A number of additional camera-related settings and calibrations must be completed in the Video app before Augmented Reality features can be used:

- Camera height above the waterline.
- Camera direction.
- Camera horizontal field of view [not required for cameras which auto assign their field of view].
- Horizon calibration.

Note:

- The camera's height above the waterline and camera's view direction need to be physically measured for accurate camera installation.
- The camera's horizontal field of view can be found in your camera's installation manual specification.

Fixed camera calibration

Fixed mount cameras require calibration for Augmented Reality to function correctly.

1. For first time setup, either:
 - i. Select the **Enter Details** prompt in the Video app.
 - ii. Select the **ClearCruise** tab in the Video app's Settings, **Video app > Settings > ClearCruise**. There will be a prompt to **Enter Details** using the **Camera Installation** page.
2. Go directly to the **Camera Installation** page in the Video app (**Settings > Camera Setup > Camera Installation**).
3. The **Camera Installation** page will offer a series of camera installation options which all need to be completed correctly.

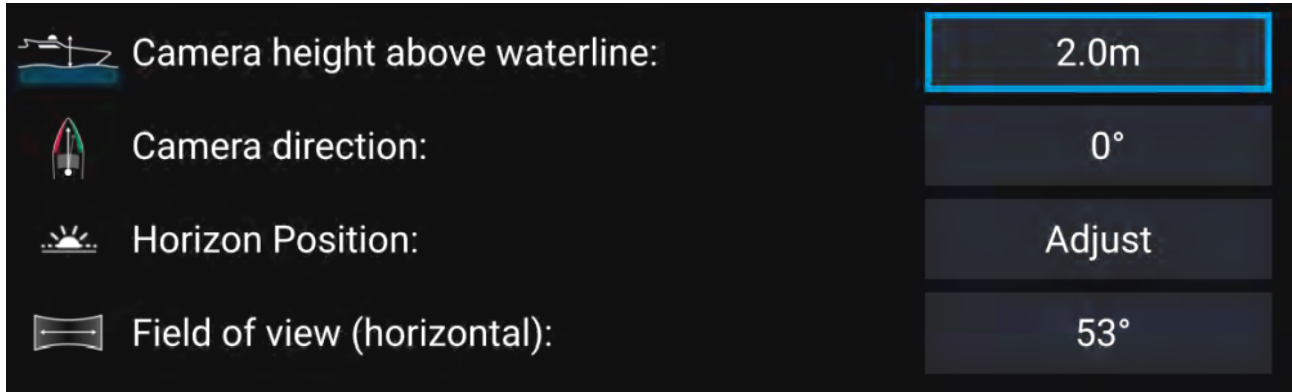

Note:

Incorrect physical camera installation and incorrect settings provided in the camera setup page could result in an inaccurate Augmented Reality overlay.

- To adjust the values of **Camera height above waterline**, **Camera direction** and **Field of view**, select the value boxes of each option and adjust using the arrows.

Menu item	Options
Camera height above waterline	<ul style="list-style-type: none"> • 0m to 50m • 0ft to 165ft
Camera direction	<ul style="list-style-type: none"> • 0° (Forward) (default) • 0° to 180°p (Port) • 0° to 180°s (Starboard)
Field of view	<ul style="list-style-type: none"> • 30° to 120° • [CAM210IP – 53°] • [CAM220IP – 93°]

- To Calibrate horizon, use the **up**, **down**, **rotate left** and **rotate right** arrow keys until the red line is placed on the horizon. When the line is in position, select **Save**.

Important:

Calibrating the horizon correctly is essential for accurate Augmented Reality overlay. Calibrating on calm water and in clear sight of the horizon is recommended.

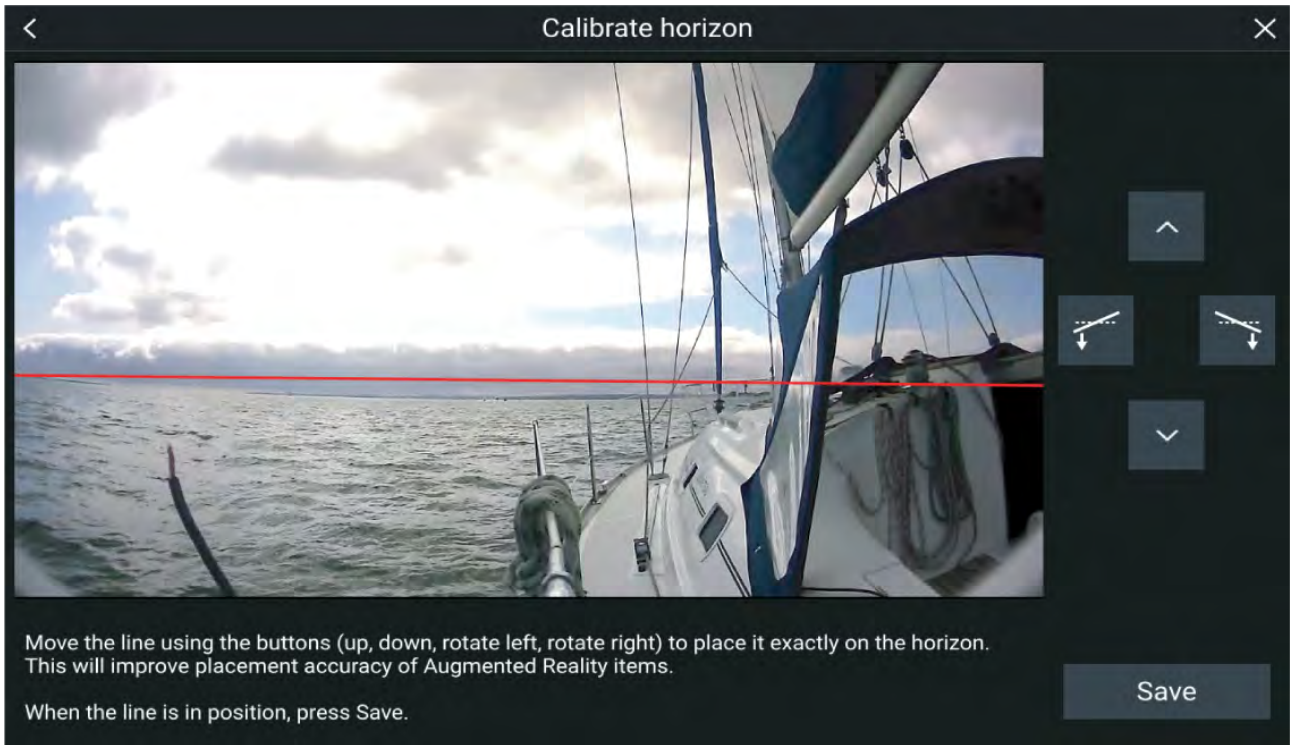

Pan and Tilt camera calibration

Pan and Tilt cameras require calibration for Augmented Reality to function correctly.

1. For first time setup, either:
 - i. Select the **Enter Details** prompt in the Video app.
 - ii. Select the **ClearCruise** tab in the Video app's Settings, **Video app > Settings > ClearCruise**. There will be a prompt to **Enter Details** using the **Camera Installation** page.
2. Go directly to the **Camera Installation** page in the Video app (**Settings > Camera Setup > Camera Installation**).
3. The **Camera Installation** page will offer a series of camera installation options which all need to be completed correctly.

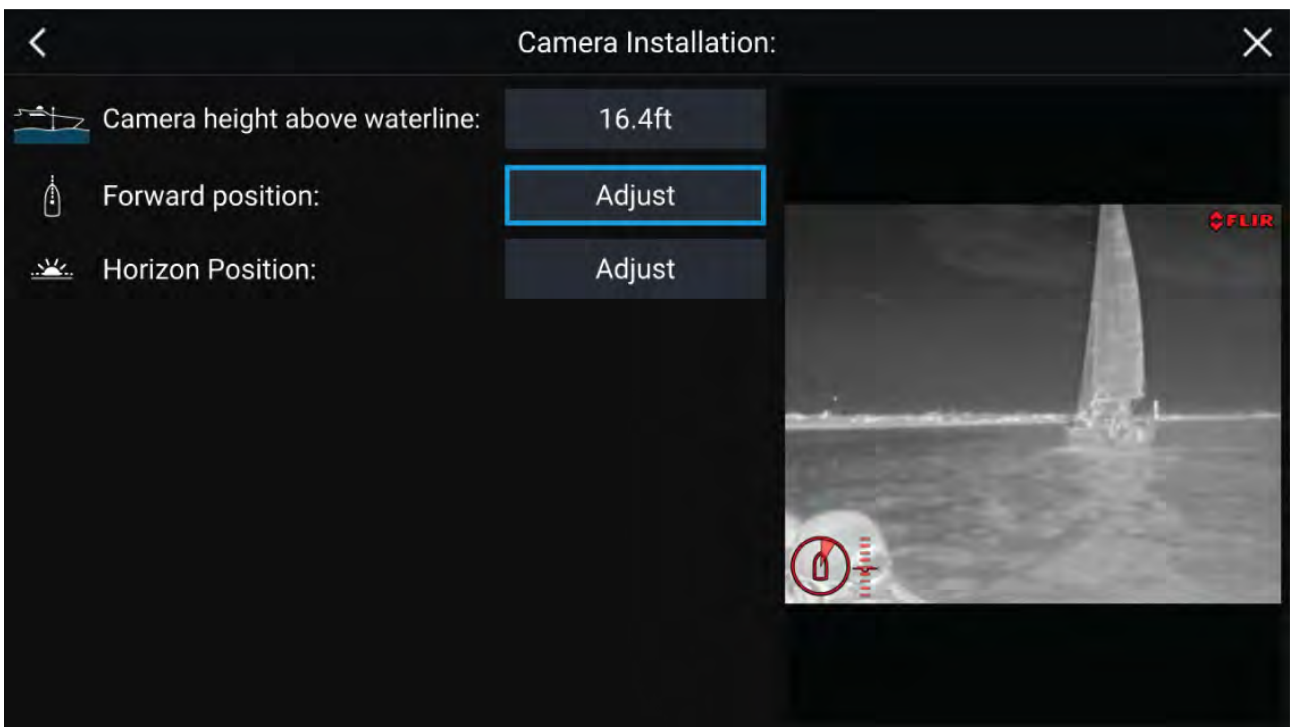

Note:

Incorrect physical camera installation and incorrect settings provided in the camera setup page could result in an inaccurate Augmented Reality overlay.

- To adjust the values of **Camera height above waterline** select the value box and adjust using the arrows.

Menu item	Options
Camera height above waterline	<ul style="list-style-type: none">• 0m to 50m• 0ft to 165ft

- To Calibrate the camera's **Forward Position** adjust the camera direction so the vertical black line is positioned directly forward, parallel to your vessels forward position.

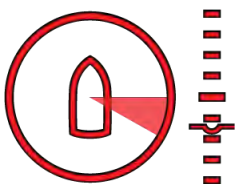

Important:

- Calibrating the cameras forward position is essential for accurate Augmented Reality overlay when the camera pans and tilts. Calibrating on calm water and with a clear view of the front of your vessel is recommended.
- Certain cameras display a camera direction indicator which can help identify when the camera is facing directly forward.

- To Calibrate the camera's **Horizon position** use the arrow keys to align the horizontal red line so it is level with the horizon.
- Pan and tilt the camera 360° during calibration to ensure the horizon line has been positioned correctly.

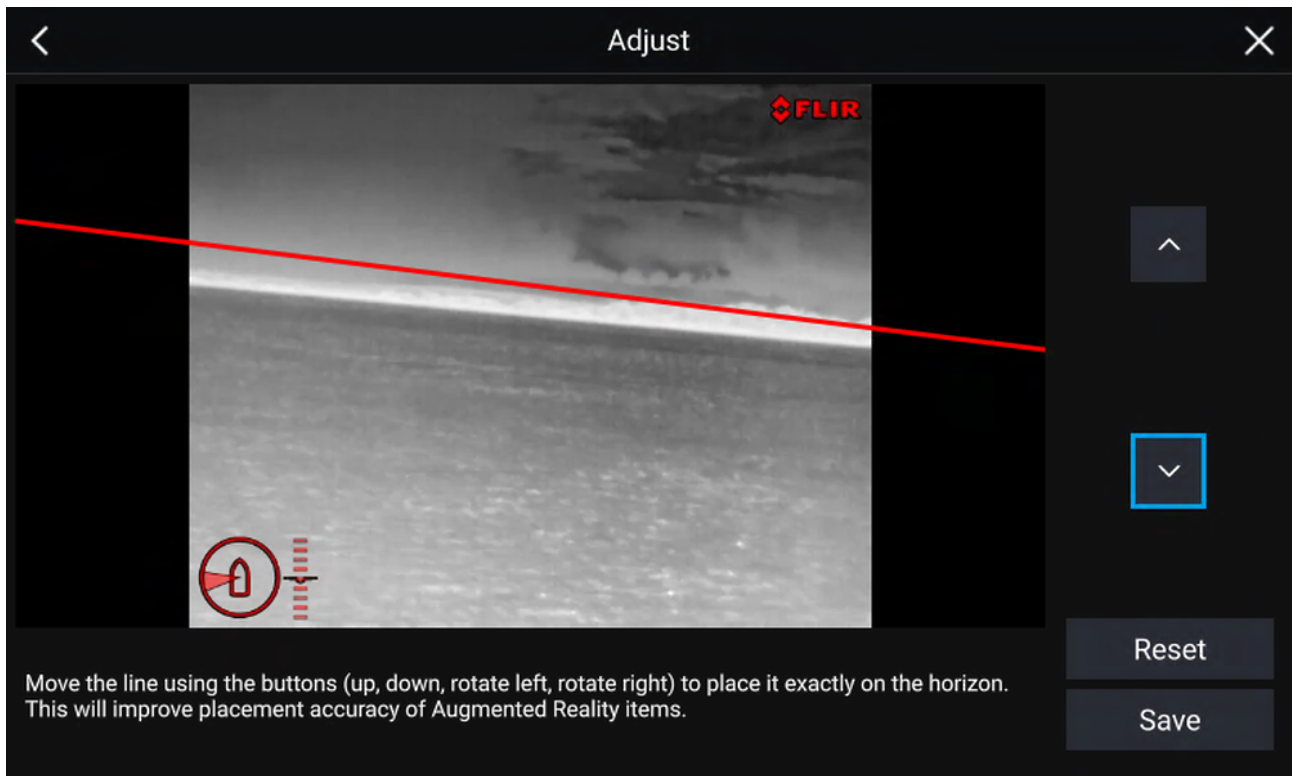

Important:

Calibrating the horizon correctly is essential for accurate Augmented Reality overlay. Calibrating on calm water and in clear sight of the horizon is recommended.

17.3 AR200 setup for Augmented Reality

Before using the Augmented Reality features, it's important to correctly install and setup the AR200 Augmented Reality sensor.

Refer to the AR200 Installation manual (87372) to determine the correct physical installation and connections for using the AR200 as part of an Augmented Reality system.

17.4 ClearCruise™ Object Detection (Video Analytics) overview

The Object Detection (Video Analytics) features provide audible and visual alerts when “non-water” objects are identified by connected M100/M200/M300 Series cameras.

Objects that visually differ from the water will be identified by the camera as a “non-water” object.

The following features are available with Object detection:

- **Highlight detected objects** — Enables/disables object highlighting, which automatically identifies and highlights “non-water” objects.
- **Beep on detection** — Enables/disables an audible beep when an object is detected (**Highlight detected objects** must be enabled)
- **Display estimated range** — Enables/disables display of an object’s estimated range from your vessel (**Highlight detected objects** must be enabled, and object must be closer than approximately 100 m (~300 ft)).

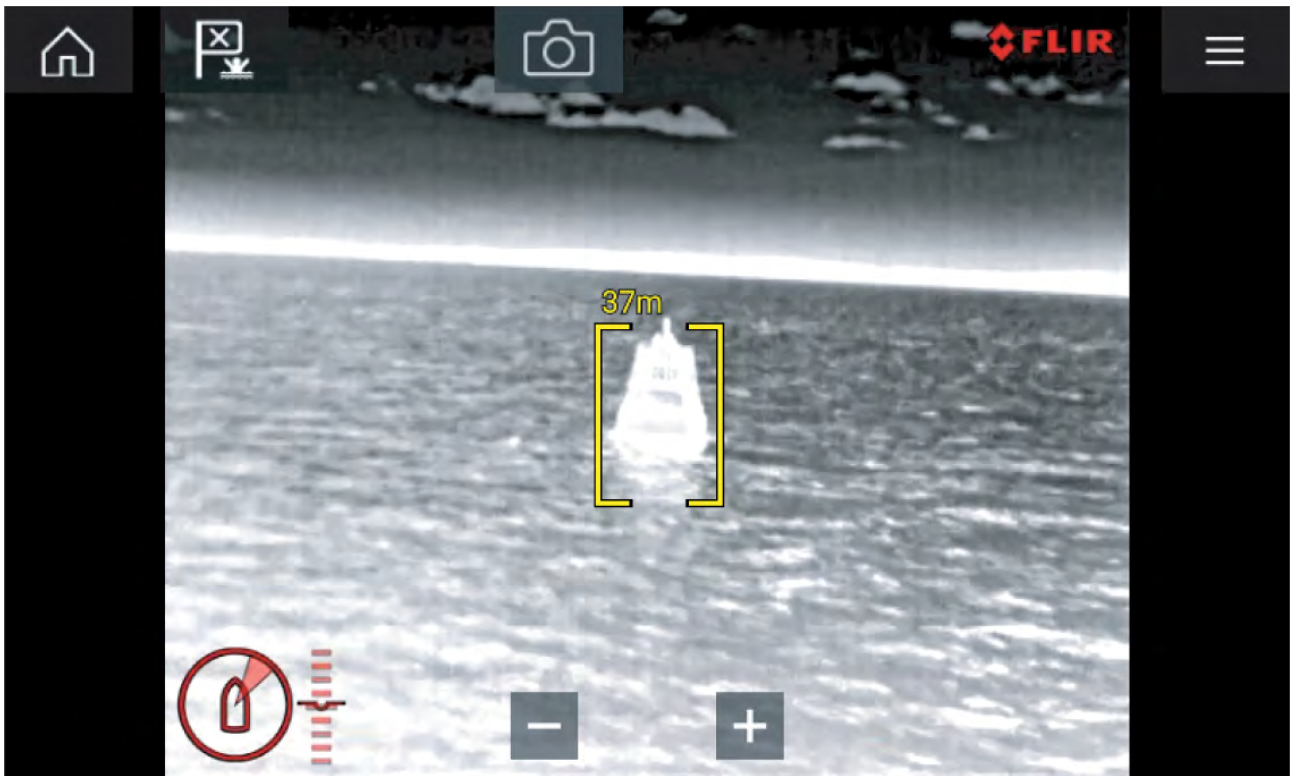

- Object detection can be particularly useful at night or visually limiting environments such as storms or fog.
- In the event of an emergency, such as man overboard, Object detection could be a useful aid that helps to identify and predict the distance from the MOB.

Note: ClearCruise's performance is dependent on conditions and is not a replacement for maintaining a visual watch.

ClearCruise settings (Object Detection / Video Analytics)

Object Detection (Video Analytics) features and settings can be enabled and disabled in the **ClearCruise** tab in the Video app.

Video app > Settings > ClearCruise

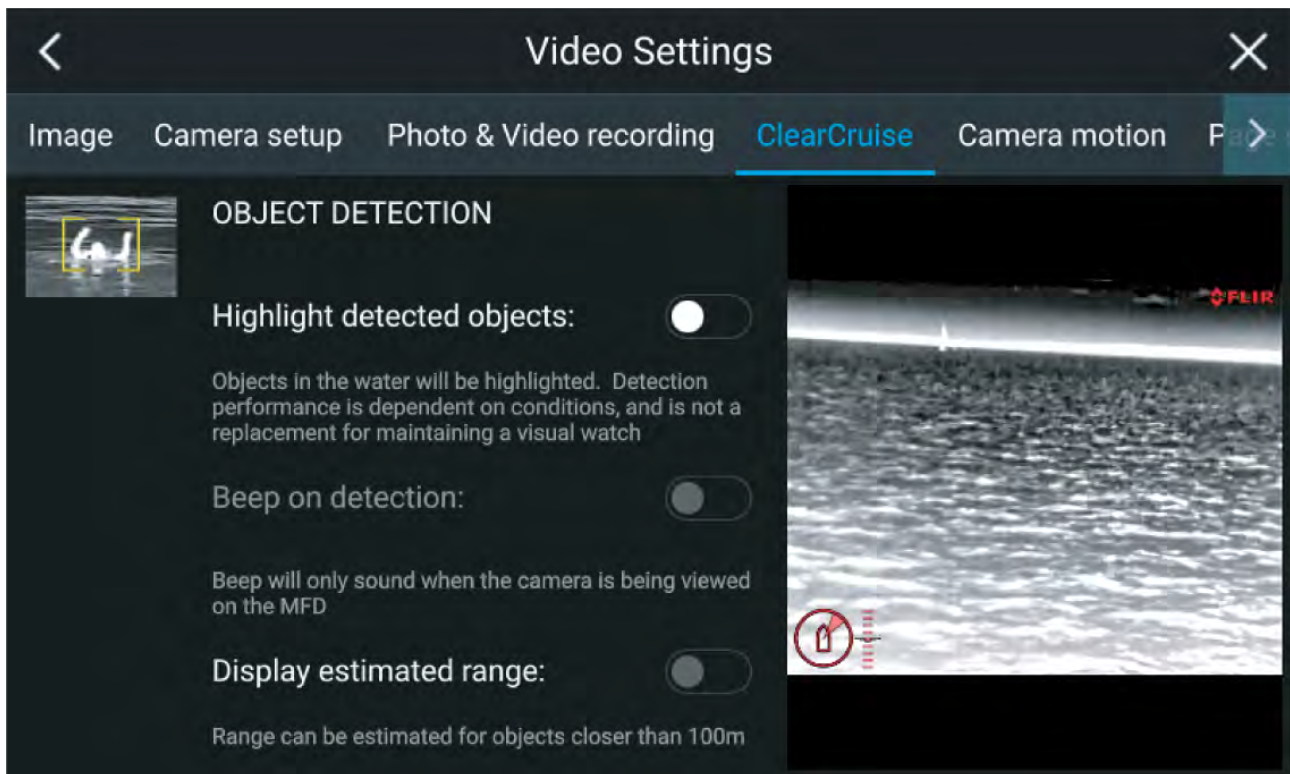

Setting	Description
Highlight detected objects	Enables/disables object highlighting.
Beep on detection	Enables/disables an audible beep when an object is detected (Highlight detected objects must be enabled).
Display estimated range	Enables/disables display of an object's estimated range from your vessel (Highlight detected objects must be enabled, and the object must be closer than approximately 100 m (~300 ft).

Important: ClearCruise Object Detection (Video Analytics) is only compatible with cameras that are positioned upright. ClearCruise Object Detection will not function with cameras that are upside down and have vertical flip enabled.

17.5 Augmented Reality (AR) overview

ClearCruise™ Augmented Reality uses data from the Chart app and displays this data in realtime as an overlay in the Video app.



The **Augmented Reality** feature places layers of digital information directly over the top of the Video app's video feed. Data from the Chart app is used to generate informative text and images (flags) on the Video app. When calibrated correctly, ClearCruise™ Augmented Reality accurately overlays automatically-updating flags on the Video app so they overlap real-life objects.

The Augmented Reality feature requires an Axiom, Axiom Pro or Axiom XL MFD, an AR200 sensor and a compatible camera.

For more information, refer to: [p.336 — ClearCruise™ features](#)

Note:

- The Augmented Reality feature requires correct camera calibration for accurate image overlay.
- The Augmented Reality feature serves as an aid to navigation and situational awareness only, and should not be solely relied on for precise navigation. Always maintain a visual watch.

Important: Rear-facing cameras with a flipped or mirrored image may not place Augmented Reality content as accurately as a forward-facing camera.

17.6 Augmented Reality flags

ClearCruise™ Augmented Reality displays AIS Targets, Waypoints and Chart Objects as individual Augmented Reality **Flags** in the Video app.

All flags display an icon and your vessel's distance from the target's location.

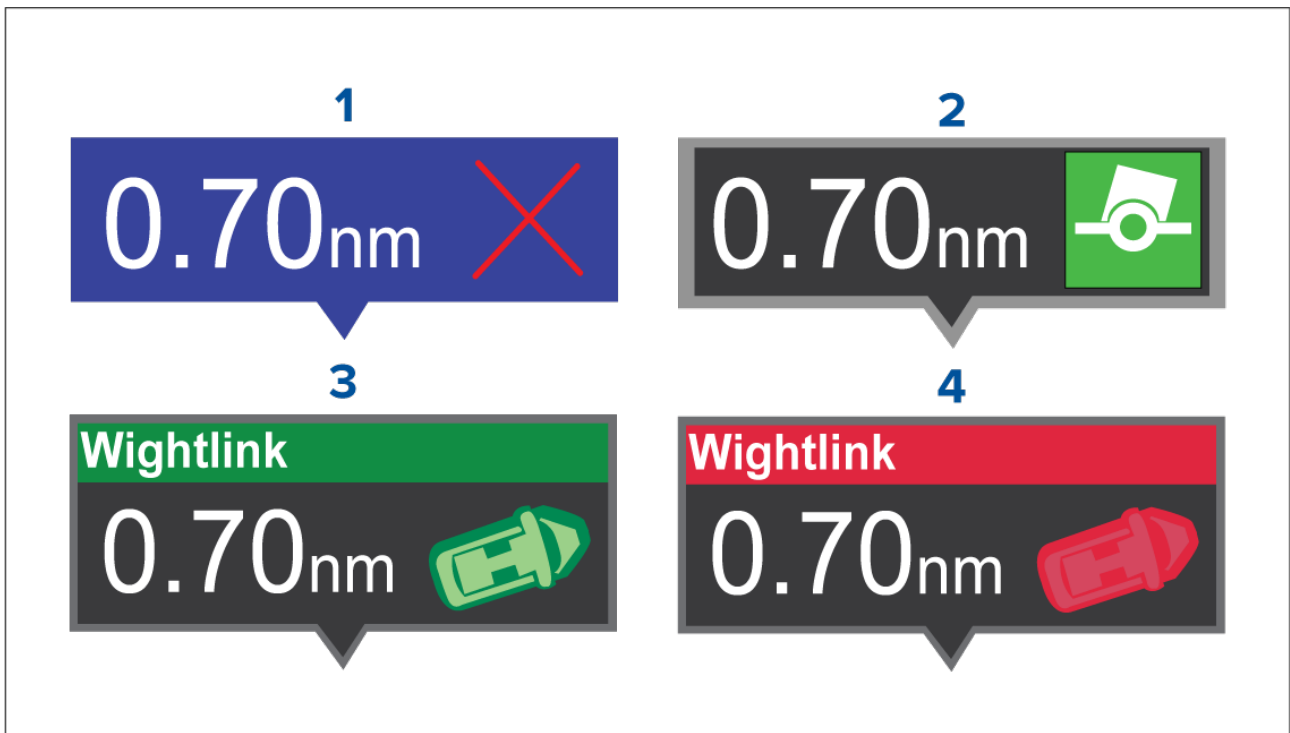

1	Waypoint flag
2	Chart Object flag (buoy)
3	AIS Target flag (passenger ferry; icon points in the direction of travel relative to the camera feed)
4	Dangerous AIS Target flag (passenger ferry; icon points in the direction of travel, relative to the camera feed)

Note: AIS flags update periodically; however, accurate placement is not guaranteed.

- AIS Targets, Waypoints and Chart Object flags can be quickly enabled / disabled via buttons in the Video app.
- The maximum range within which flags are automatically shown can also be adjusted in the Video app.
- For more information on adjusting flag settings, refer to: [17.1 ClearCruise™ features](#)



Selected flags

Augmented Reality flags in the Video app can be selected (highlighted), providing access to more information about the object and additional features.

A flag is an onscreen visual overlay element displayed in the Video app when the Augmented Reality features are enabled. A flag represents an object from the Chart application: e.g. AIS target, Waypoint, or other chart object.

When a flag is selected, the corresponding object is also highlighted in the Chart app. Conversely, selecting an object in the Chart app highlights the corresponding flag in the Video app.

Only one flag may be selected at a time.

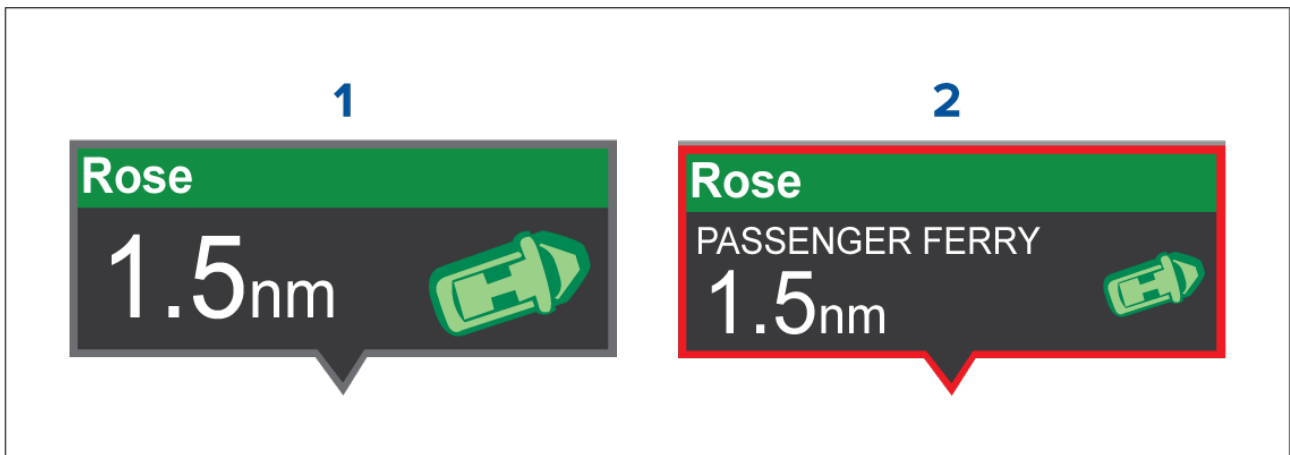

1	AIS Flag
2	Selected AIS Flag



Selecting a flag highlights it in red and provides additional information about the object in a context menu. The menu also provides additional features. The range of features available in the context menu depends on the type of object selected:

AIS Target Flag

Option	Description
AIS Target name	The name of the target vessel.
Target data	Vessel (name), CPA, TCPA, COG, SOG.
View AIS data	Displays the AIS data transmitted by the target vessel.

Option	Description
Buddy (toggle ON/OFF)	Add the vessel to your “Buddy List”, with the option to rename it. The Buddy feature enables you to add AIS-equipped friends and regular contacts to a “Buddy List” on your MFD. As soon as a vessel on your Buddy List comes within range of your AIS receiver, the onscreen vessel icon changes to indicate this.
Goto	The Chart app will plot a direct route to the last known location of the target.
Place waypoint	The Chart app will place a waypoint at the last known location of the target.

Waypoint Flag

Option	Description
Waypoint name	The name of the waypoint.
Target data	Lat, Lon, Rng, Brg.
Goto	The Chart app will plot a direct route to the last known location of the target.
Delete	Delete the waypoint.
Edit	Edit the waypoint’s Name, Symbol, Group, Position, and add a Comment.

Chart Object Flag

Option	Description
Chart Object name	The name of the chart object.
Target data	Lat, Lon, Rng, Brg.
Goto	The Chart app will plot a direct route to the last known location of the target.

Goto flag

Selecting **Goto** on a selected Augmented Reality flag will plot a direct course to the flag’s last known location.

A **Goto** flag will appear in the last known location of the selected flag in both the Video and Chart apps, and in the Video app’s **Compass bar**. The flag is displayed with a Goto icon, as a blue copy of the original flag.

Selecting the **Goto** flag makes it a selected flag, and also displays a context menu providing more information about the location of the flag, and the option to stop a goto action.

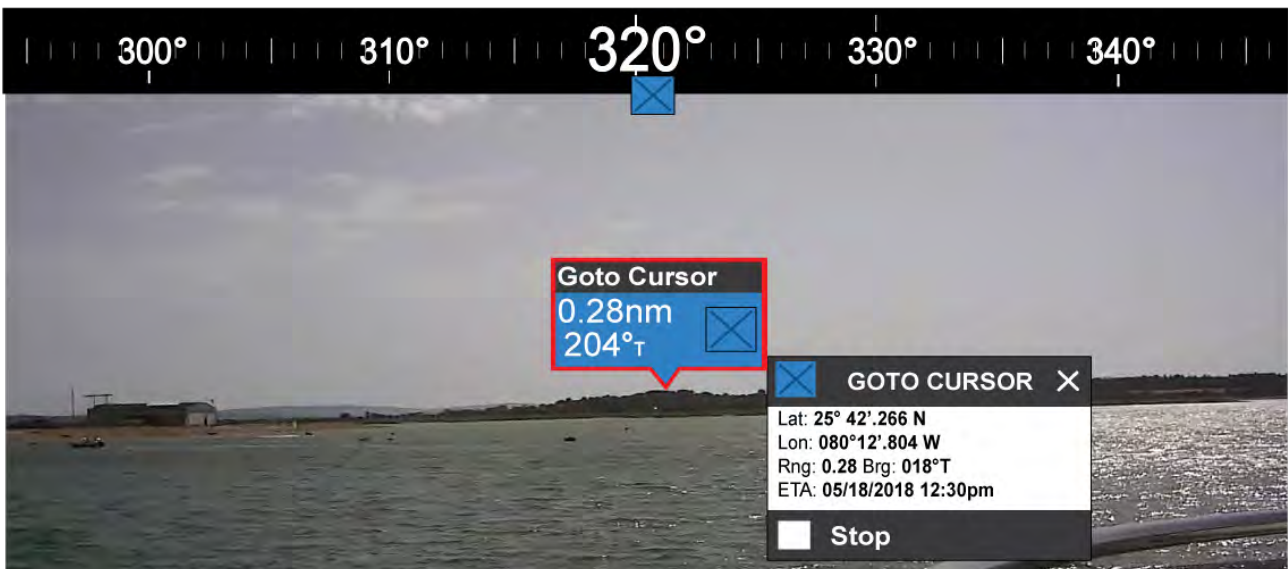

- Selecting **Stop** removes the Goto flag from the Video app and Chart app.
- If the camera loses sight of the **Goto** flag, it will display red and green navigational arrows on the **Compass bar**, indicating whether you need to turn port or starboard to regain sight of the flag. However, this only works if the camera is forward-facing.

17.7 ClearCruise settings (Augmented Reality)

Augmented Reality settings can be edited in the **ClearCruise** tab in the Video app.

Setting	Description
AIS labels	Enables/disables the display of other vessels as Augmented Reality flags (requires AIS).
Hide static targets	Enables/disables the display of AIS targets travelling under 2 knots (requires AIS).
Waypoints	Enables/disables the display of Waypoint Augmented Reality flags.
Chart objects	Enables/disables the display of Chart objects (requires compatible charts).
Cartography source	Select the cartography source that the ClearCruise™ features will use for the display of chart objects in the Video app Augmented Reality features. (Requires compatible charts).
Compass	Enables/disables the display of the Compass bar in the Video app.
Range limit	Sets the maximum range at which the camera will detect and display Augmented Reality flags. This range is displayed visually in the Chart app with the “FOV cone”. Refer to: Field of View . For the maximum range supported by your camera, refer to: Range limit

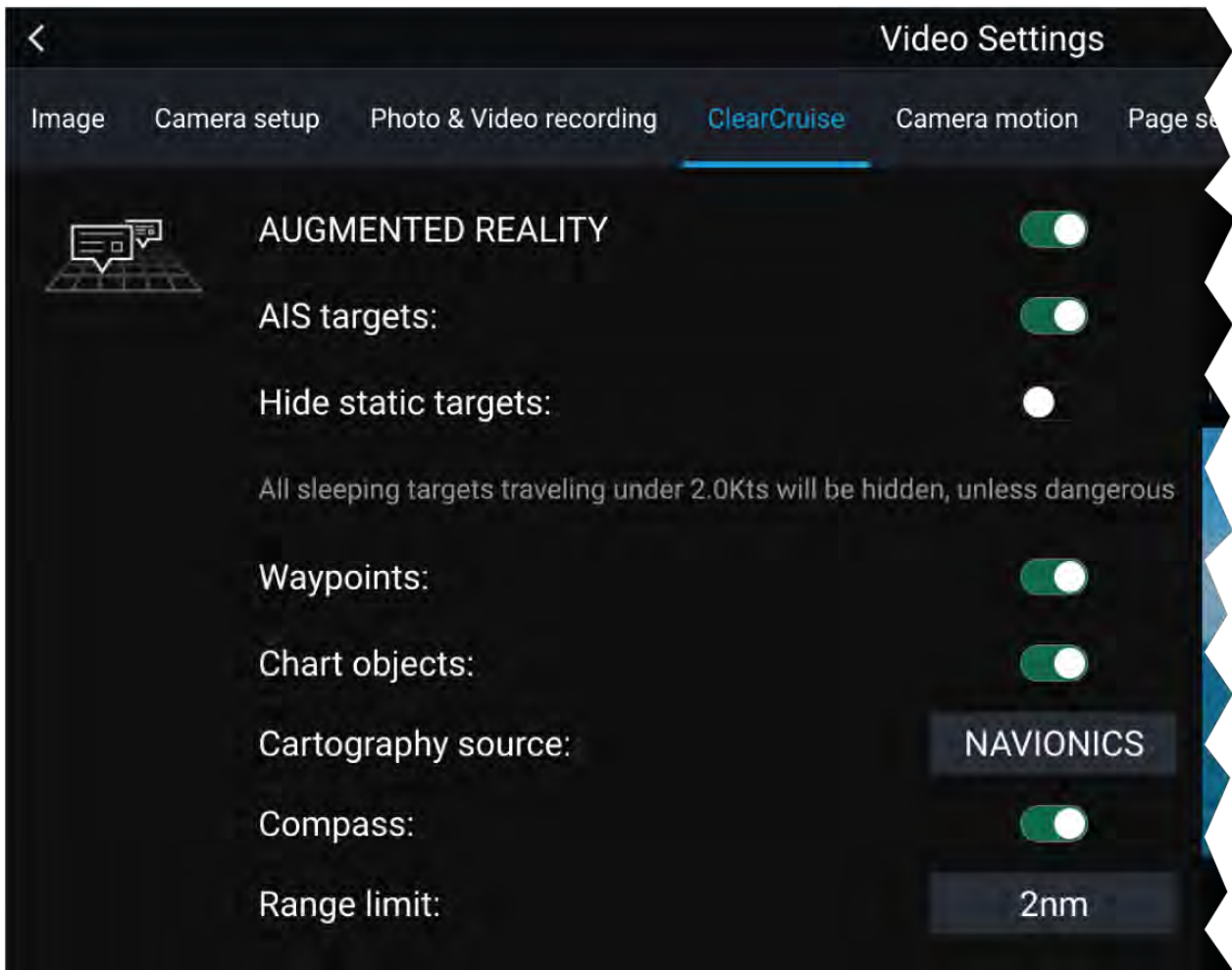

Note:

The variety of chart objects is dependent on the selected cartography source. For more information on different cartography sources, refer to: [8.10 Find nearest](#)

Range limit

The Range Limit is the maximum range at which ClearCruise™ can display AIS targets, Waypoints and Chart Object flags in the Video app.

The range limit can be checked using the Field of View (FOV) cone in the Chart app. All AIS targets, Waypoints and Chart Objects within the area of coverage of the FOV cone can be displayed as Augmented Reality flags in the Video app. For more information, refer to: [Field of View](#)

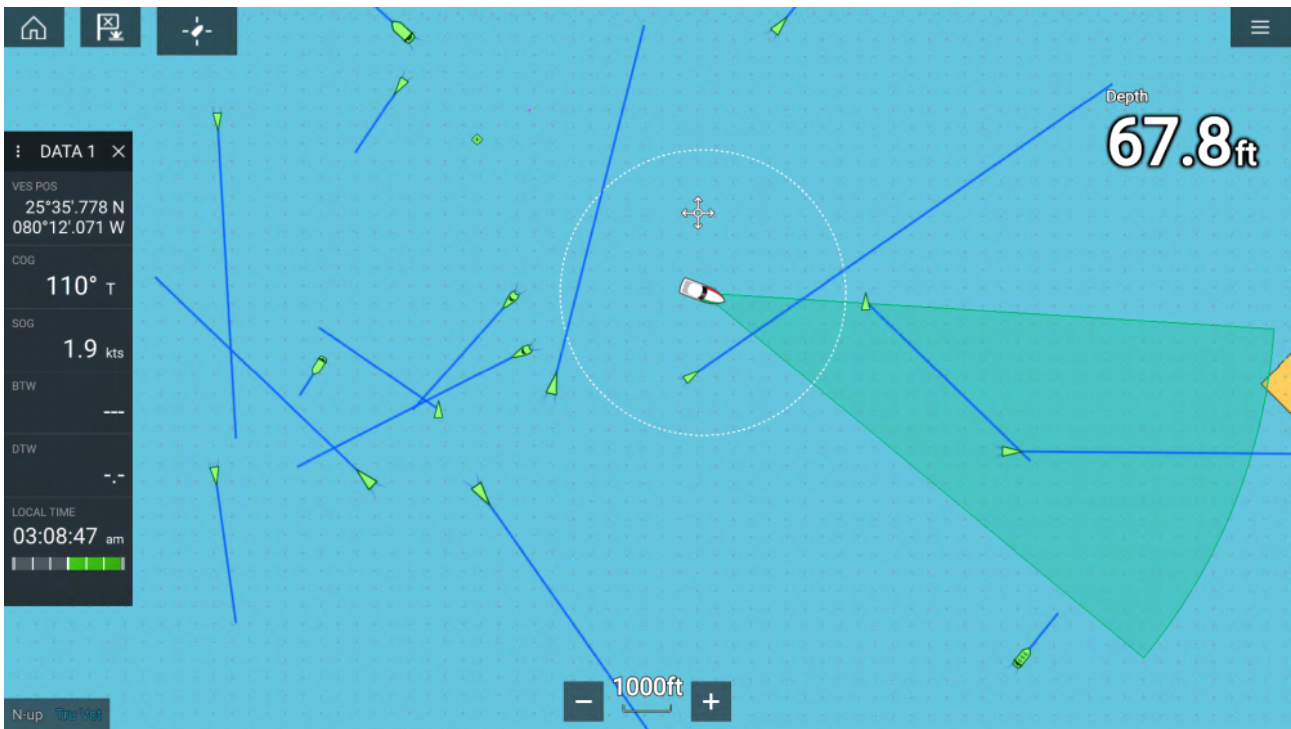

Note:

Some chart objects just outside of the FOV cone might still display in the Video app as flags.

You can specify this range limit manually in the Video app: **Video Settings > ClearCruise tab**. Any adjustments you make will be reflected in the FOV cone display in the Chart app.

17.8 Roll correction

Roll Correction automatically adjusts the Video app image when the vessel tilts (rolls) to port or starboard.

Note: Roll correction is only available with IP cameras.

Roll Correction can be enabled/disabled in the Video app: **Settings > Image**.

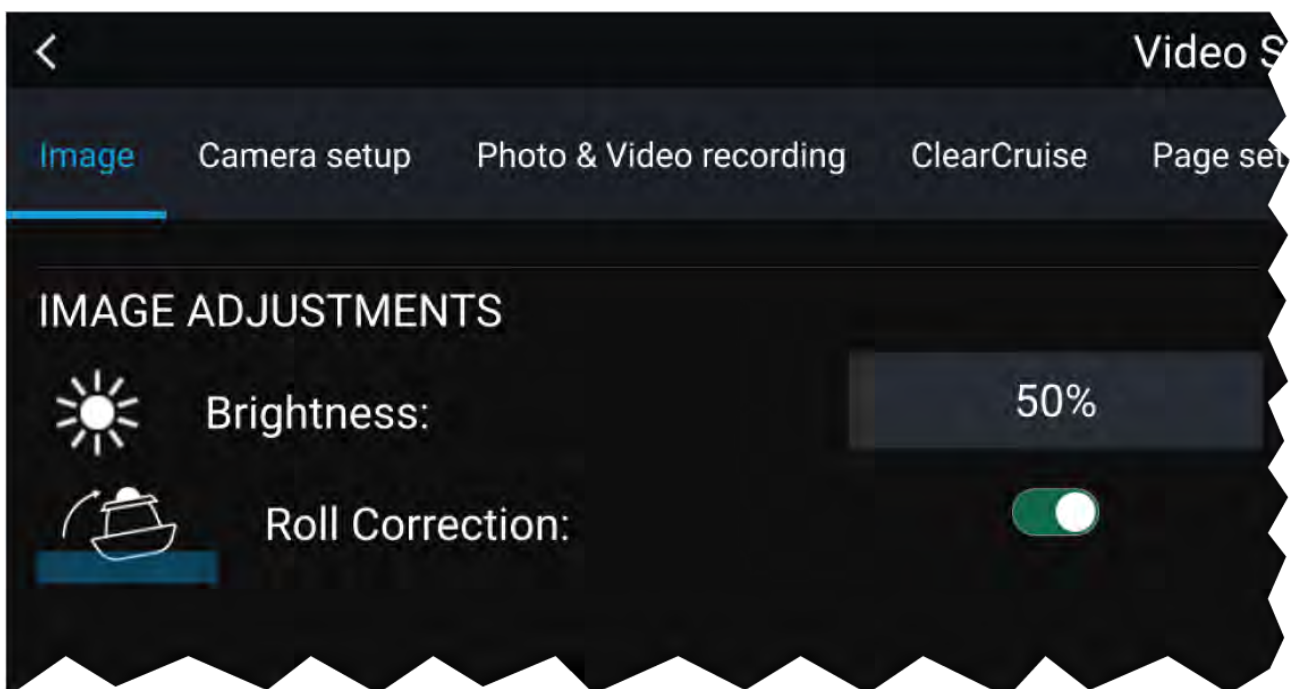

When enabled, the Roll Correction feature accounts for the boat tilting and stabilizes the video feed accordingly. This means that the video feed's horizon will be parallel with the actual horizon. When disabled, the video feed will tilt with the boat and the MFD screen.



1	Roll correction disabled
2	Roll correction enabled

17.9 AR200 Calibration (Linearization)

To enable accurate placement of Augmented Reality (AR) flags on the camera's video feed, the AR200's AHRS sensors need to compensate for local magnetic fields, as well as the Earth's magnetic fields.

Calibration is achieved using an automatic linearization process. The linearization process starts automatically after your vessel has turned approximately 100°, when travelling at a speed of between 3 to 15 knots. The linearization process requires no user input, however at least a 270° turn is required before linearization can be completed. The duration of the linearization process can be decreased by completing a full 360° turn, when travelling at a speed of between 3 to 15 knots. The linearization process can also be restarted at anytime.

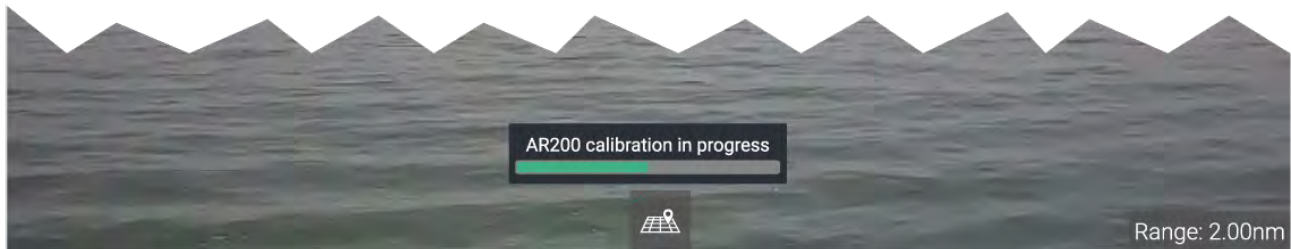

In the Video app the Linearization progress bar is displayed when linearization is in progress. The bar is filled to indicate completeness, and will turn Red if the process is paused or otherwise interrupted.

The time taken to complete the linearization process will vary according to the characteristics of the vessel, the AR200's installation location, and the levels of magnetic interference present at the time linearization is performed.

Magnetic interference can be caused by objects onboard your vessel, such as:

- Speakers
- Electronic equipment
- Electrical cabling
- Metal bulkhead or hull

Magnetic interference can also be caused by external objects in close proximity to your vessel, such as:

- Metal hulled vessels
- Underwater electrical cables
- Marine pontoons

Magnetic deviation

Magnetic deviation is the error induced in a compass caused by interference from local magnetic fields.

The automatic linearization process results in a deviation value being set for your AR200. If Augmented Reality flags in the Video app are not aligned with their onscreen objects, or the compass is out of alignment, you should check the AR200's current calibration settings. For instructions on how to do this, refer to: [AR200 calibration settings](#)

AR200 calibration settings

The calibration settings page provides access to the AR200's compass calibration options.

The AR200 calibration page can be accessed using your Data master MFD; from the Homescreen select: **Settings > Network > Data sources > Heading > AR200 > Calibrate.**

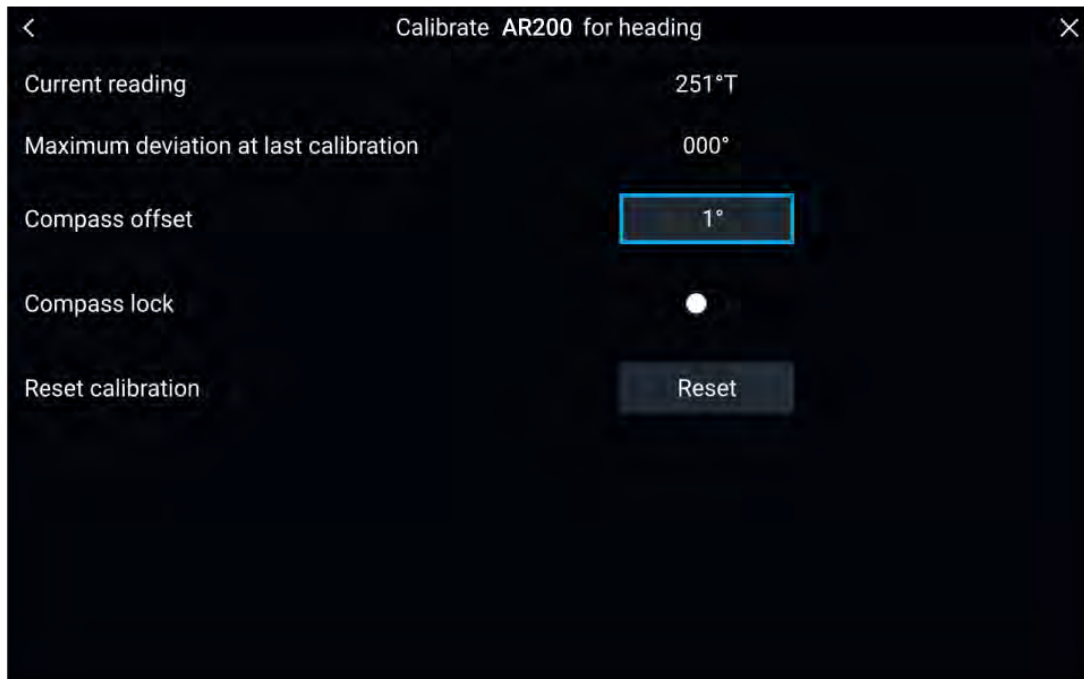

1	<p>Current reading: The current heading reported by the AR200.</p>
2	<p>Maximum deviation at last calibration: The maximum deviation reported during the last linearization process.</p> <hr style="border: 2px solid red;"/> <p>Important:</p> <ul style="list-style-type: none"> If the Maximum deviation at last calibration is 45° or above, it is recommended that the AR200 unit is moved and re-installed in a location which is subject to less magnetic interference. <p>Calibration in progress: While linearization is in progress the progress percentage is displayed.</p>
3	<p>Compass offset Once the linearization process has completed, it is possible that the heading value may be slightly out of alignment. This is common where installation space is limited and the AR200 is not properly aligned with your vessel's longitudinal axis. In this case, it is possible to manually adjust the Compass offset.</p>
4	<p>Compass lock When enabled, the Compass lock prevents the continual monitoring and adaptation of the compass linearization process. For more information, refer to: Compass lock.</p>
5	<p>Reset calibration You can reset your AR200's current linearization settings by selecting Reset calibration</p>

Continual monitoring and adaptation

To ensure optimum performance, after the initial linearization process is complete the unit continues to monitor and adapt the compass linearization to suit current conditions.

If the conditions for linearization are less than ideal, the automatic linearization process temporarily pauses until conditions improve again. The following conditions can cause the linearization process to temporarily pause:

- significant magnetic interference is present
- vessel speed too slow or too fast

- rate-of-turn too slow or too fast

Compass lock

Once you are satisfied with the compass accuracy, you can lock the setting to prevent the system from completing a further automatic linearization in the future.

This feature is particularly useful for vessels in environments that are exposed to strong magnetic disturbances on a regular basis (such as offshore wind farms or very busy rivers, for example). In these situations it may be desirable to use the Compass lock feature to disable the continuous linearization process, as the magnetic interference may build a heading error over time.

Note: The compass lock may be released at any time, to allow the compass continual monitoring and adaptation to re-commence. This is particularly useful if planning a long voyage. The earth's magnetic field will change significantly from one geographical location to another, and the compass can continually compensate for the changes, ensuring you maintain accurate heading data throughout the voyage.

Chapter 18: Audio app

Chapter contents

- [18.1 Audio app overview on page 356](#)
- [18.2 Opening the Audio app on page 361](#)
- [18.3 Getting started on page 362](#)
- [18.4 Audio app menu options on page 364](#)

18.1 Audio app overview

The Audio app can be used to control compatible entertainment systems that are connected to the same network as your MFD.

The Audio app can be displayed in Fullscreen and half screen portrait app pages.

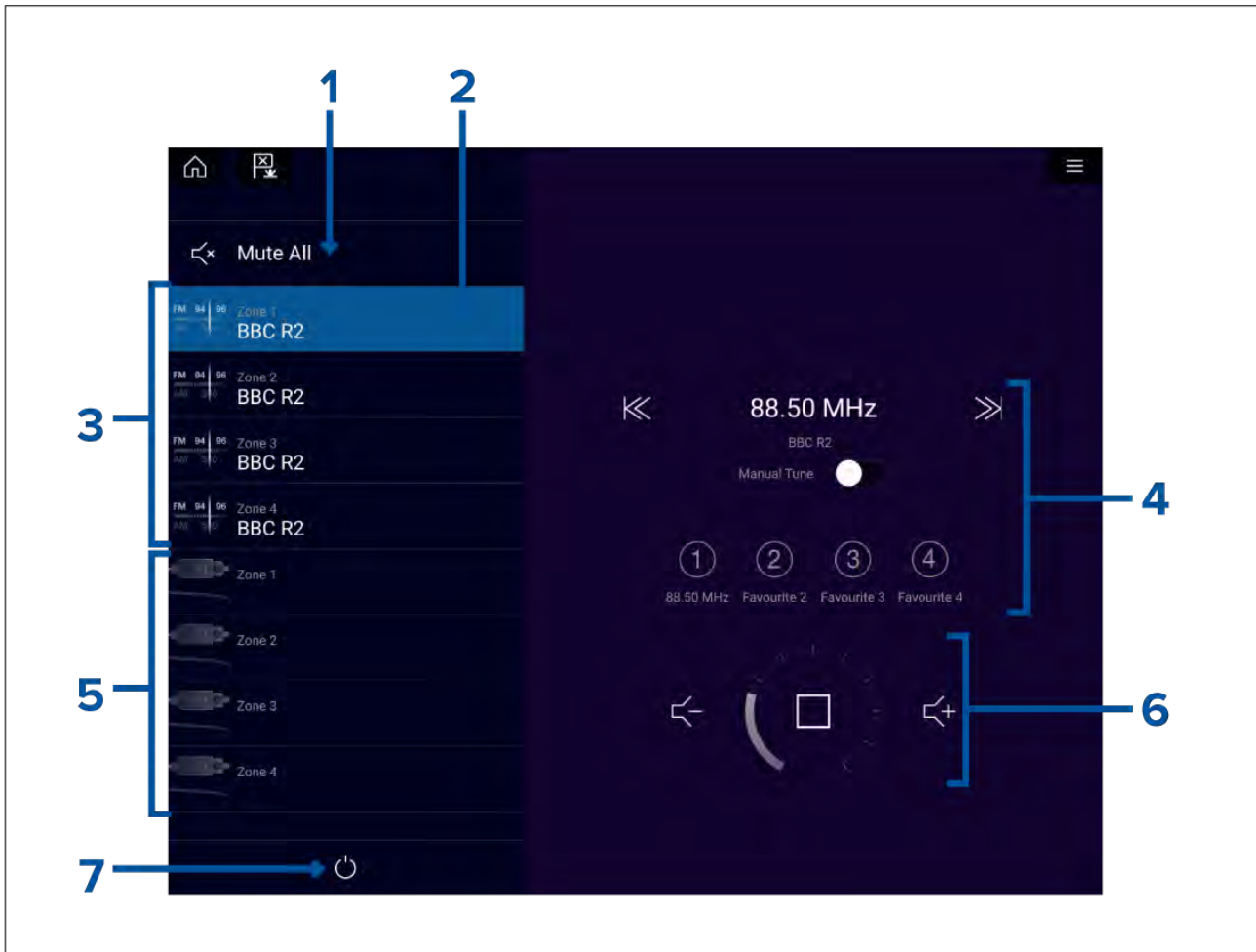

1. **Mute All** — Mutes all zones on the currently selected system.
2. Currently selected zone.
3. System 1 available zones.
4. Audio source and controls for currently selected zone.
5. System 2 available zones.
6. Zone volume and player controls for currently selected zone.
7. **Power** — Power on or off connected entertainment systems.

Compatible entertainment systems

The table below lists compatible entertainment systems which have been approved for use with the MFD Audio app. The Audio app can be used to control up to 3 entertainment systems from the same manufacturer. However, connecting entertainment systems from Fusion and Rockford Fosgate at the same time is NOT supported.

SiriusXM receivers

Model number	Raymarine part number	Supported Network connection
SR150	E70161	Ethernet / RayNet
SR200	E70499	Ethernet / RayNet

Rockford Fosgate entertainment systems

Model number	Raymarine part number	Supported Network connection
RMX-2	E70397	NMEA 2000
RMX8DH	E70394	NMEA 2000
RMX8BB	E70395	NMEA 2000
RMX5CAN	E70396	NMEA 2000

Fusion entertainment systems

Model number	Supported Network connection
AV750	NMEA 2000 Ethernet
AV755	NMEA 2000 Ethernet
BB100	NMEA 2000
BB300	NMEA 2000
RA70	NMEA 2000
RA70N	NMEA 2000
RA205	NMEA 2000
RA670	NMEA 2000 Ethernet
RA770	NMEA 2000 Ethernet
SRX400	Ethernet
UD750	NMEA 2000 Ethernet
UD755	NMEA 2000 Ethernet

JL Audio









Model number	Supported Network connection
MM50	NMEA 2000
MM100s-BE	NMEA 2000
MMR-40	NMEA 2000





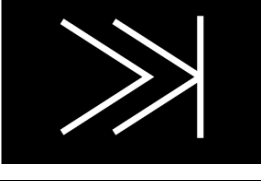

Note:

Connecting entertainment systems from Fusion and Rockford Fosgate at the same time is not supported.



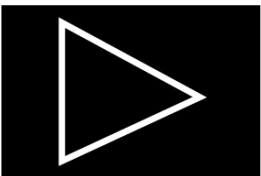

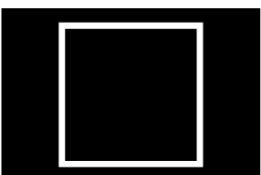
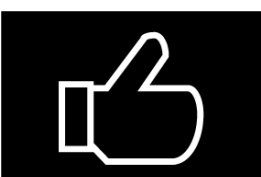
Audio app controls

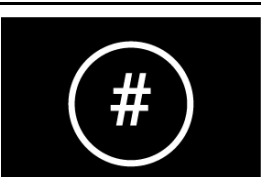
Audio player controls

Icon	Description	Function
	Power Off	Powers off the Entertainment system.
	Mute All	Mutes all audio zones.
	Volume Down	Decreases volume for current zone.
	Volume Up	Increases volume for current zone.
	Forwards	<ul style="list-style-type: none"> • Skip to the next track (USB and Bluetooth) • Seek/Search Forward (Radio) <p>Note: For SiriusXM, channel control is not available from an external audio head unit.</p>
	Backwards	<ul style="list-style-type: none"> • Skip back to beginning of current track (USB and Bluetooth) • Seek/Search Backward (Radio) <p>Note: For SiriusXM, channel control is not available from an external audio head unit.</p>
	Manual Tune	<ul style="list-style-type: none"> • On (switches Forwards and Backwards icons with Manual Tune icons) • Off
	Tune Up	Manually searches up for radio stations/channels. Note: For SiriusXM, channel control is not available from an external audio head unit.
	Tune Down	Manually searches down for radio stations/channels. Note: For SiriusXM, channel control is not available from an external audio head unit.

Icon	Description	Function
	Repeat	<ul style="list-style-type: none"> • Off • Repeat Track • Repeat All
	Shuffle	<ul style="list-style-type: none"> • On • Off
	Play	Select to commence playback.
	Pause	Select to Pause playback.
	Stop	Select to Stop (Mute) Radio devices.
	Like	Like a track (Pandora only).
	Dislike	Dislike a track (Pandora only).
	Radio presets	<p>Save your favorite radio stations/channels to 4 preset buttons. Press and hold to save, press once to change to saved station/channel.</p> <p>Note: For SiriusXM, channel control is not available from an external audio head unit.</p>

Standard app controls

Icon	Description	Function
	Menu icon	Opens the app menu.
	Home icon	Takes you to the Homescreen.
	Waypoint / MOB	Place waypoint / activate Man overboard (MOB) alarm.
	Pilot icon	Opens and closes the Pilot Sidebar

Audio sidebar

With compatible audio equipment connected the Audio sidebar is available which enables you to control your audio system from an MFD app.

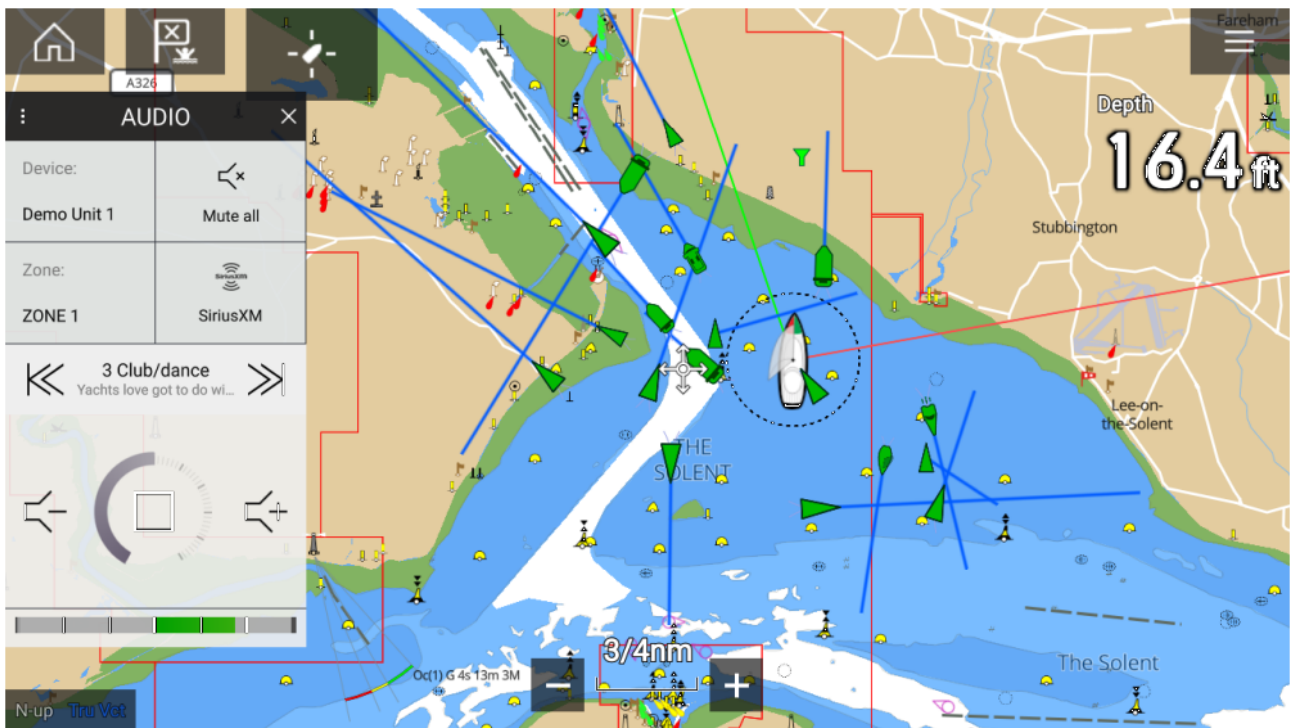

The Audio sidebar includes the following controls:

- Audio device selection.
- Zone selection.
- Source selection
- Track/Station selection.

- Volume controls.

18.2 Opening the Audio app

The Audio app is opened by selecting an app page from the Homescreen that includes the Audio app.

Pre-requisites:

1. Ensure your Entertainment system(s) are compatible by checking the latest details available on the Raymarine website. If in doubt please contact an authorized Raymarine dealer for advice.
2. Ensure you have installed your Entertainment system(s) in accordance with the documentation that was supplied with the system.

The Audio app will open in 1 of 3 states:

Audio app displayed

If your Entertainment system is powered up and operational then the player controls are displayed and can be used to control your system.

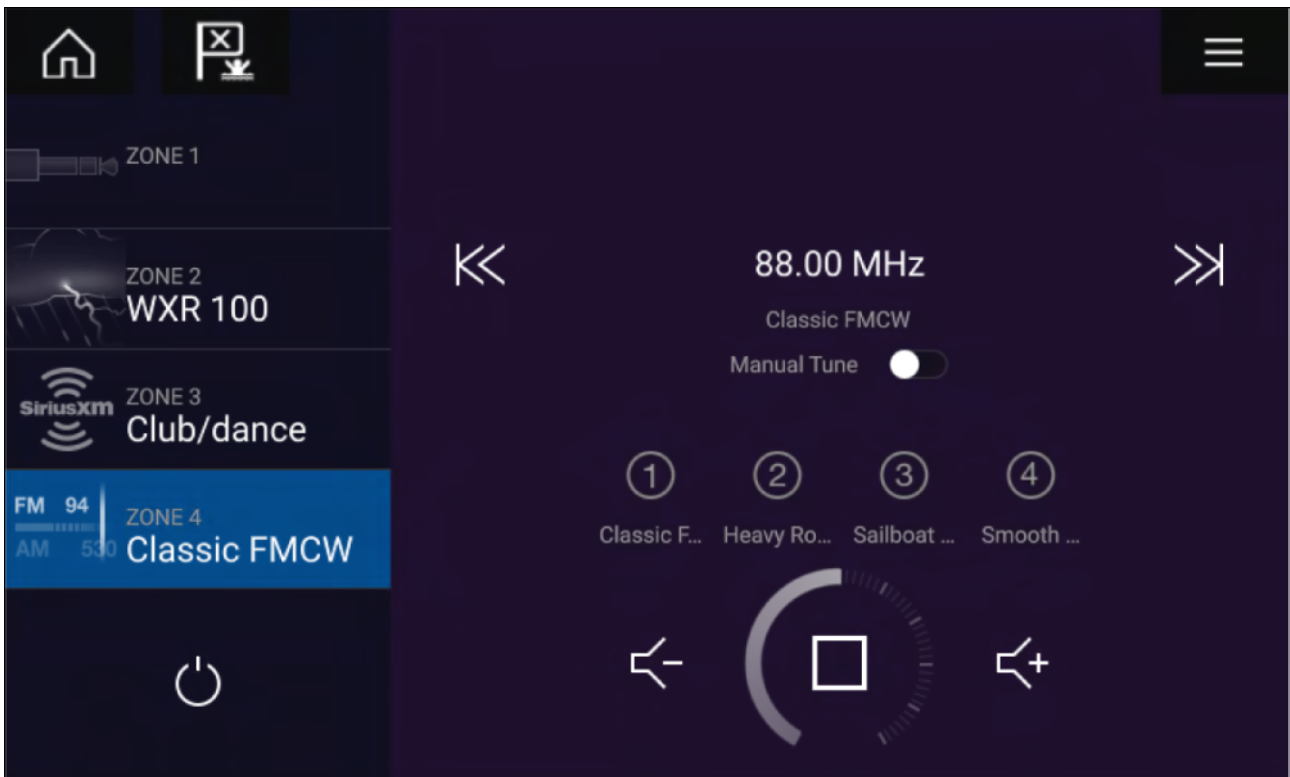

Entertainment system powered off

If all Entertainment systems are powered off then a Power icon is displayed for each connected system. An icon is also displayed to power on All systems. Selecting the **Power icon** will switch your Entertainment system on. Selecting the All icon will power on all connected systems.

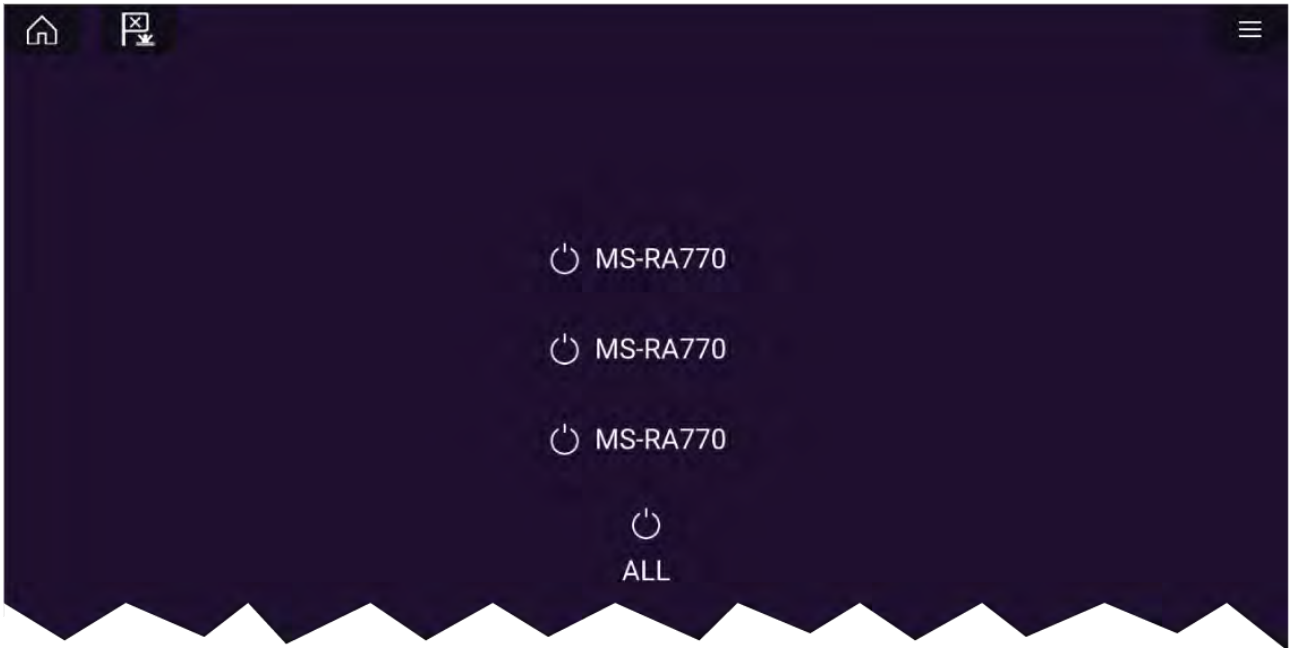

No audio devices found

If the Audio app is opened soon after powering on your MFD, the **'No audio device found'** message may be displayed whilst the network is being established. If the message is displayed for more than 10 seconds, your MFD cannot connect to your Entertainment system(s). Ensure network and power connections to your Entertainment system(s) and MFD are correct and free from damage and then power cycle your system. If the Entertainment system(s) are still not displayed then refer to your equipment's installation documentation for further troubleshooting information.

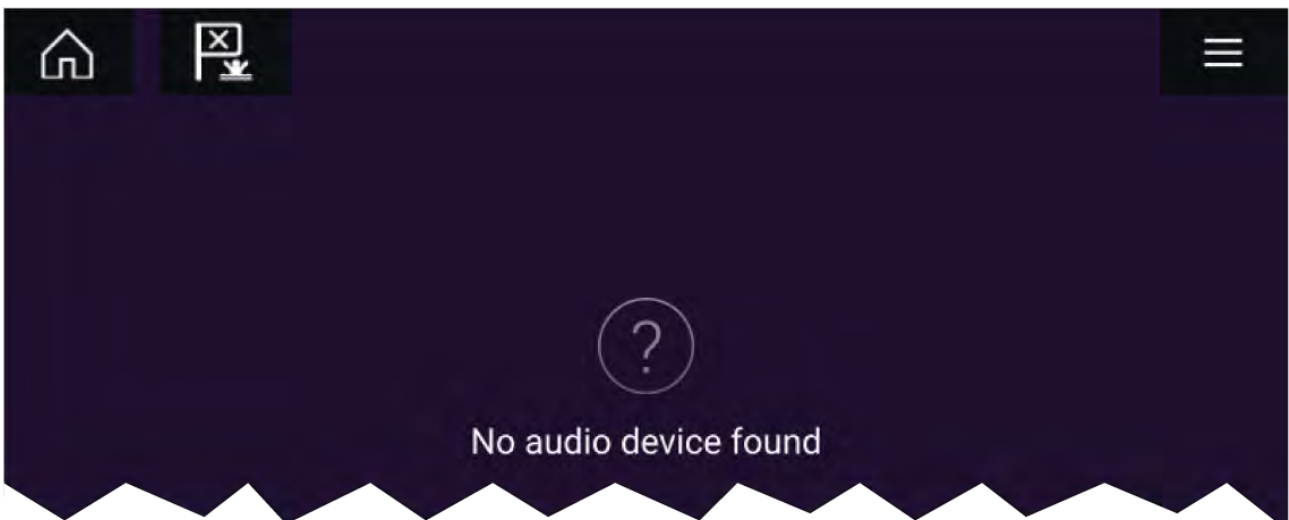

18.3 Getting started

Selecting an audio zone

If you have more than 1 zone configured, audio zones will be displayed on the left side of the screen. All zones for all connected systems will be displayed, grouped by entertainment system.

1. Select the required zone.

Details of the audio source playing in that zone are displayed along with audio controls.

Tip

Refer to the instructions provided with your entertainment system for details on naming your zones. This aids device and zone identification when multiple systems each with multiple zones are connected.

Selecting an audio source

Before you can select an audio source from your MFD, the source must already be available to your Entertainment system's main control unit ("head unit").

1. Select an audio source (mode) icon from the app **Menu**.

The currently selected zone will switch to the selected audio source. Depending on your entertainment system all zones will change and play the same audio source, or you may be able to play a different source on each zone. Check the instructions provided with your system for details.

Muting and unmuting

1. To mute the audio for all zones on all connected systems, select **Mute All**, located above the zones on the top left of the screen.

*When multiple systems are connected selecting **Mute all** will mute all zones on all connected entertainment systems.*

2. To Unmute a device select a zone for that device and then select **Unmute**.

*Selecting **Unmute** will unmute all the zones for the selected entertainment system.*

Browsing for tracks

You can browse USB and Bluetooth devices for tracks.

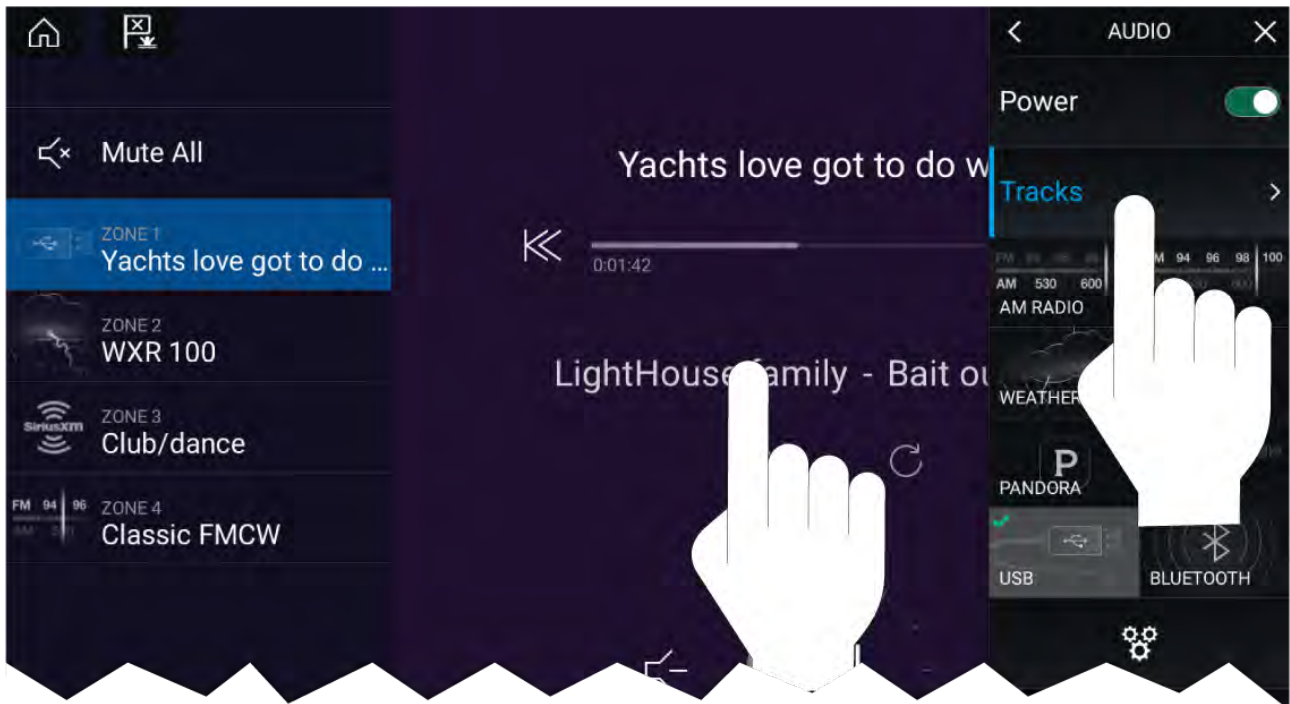

With the relevant USB or Bluetooth device selected as the audio source:

1. Select **Tracks** from the Menu.
The file browser is displayed.
2. Alternatively, you can select the current track's details to open the file browser.
3. Browse to the file you want to play.

Wait for the file list to finish loading before selecting a track.

4. Select the track you want to play.

Browsing for stations / channels

You can browse available Radio stations/channels.

With the relevant Radio device selected as the audio source:

1. Select **Stations** or **Channels** from the Menu.
The station or channel browser is displayed.
2. Browse to and select the station or channel you want to listen to.

Note: For SiriusXM, channel control is not available from an external audio head unit.

Saving presets

Up to 4 presets can be saved for each Radio audio source (i.e.: AM Radio, FM Radio, Weather, SiriusXM and Pandora).

1. Whilst listening to the station you want to save, press and hold the relevant Preset button for approximately 3 seconds.

Powering off entertainment systems

Connected entertainment systems can be powered off using the Audio app.

With the Audio app displayed and the entertainment system powered on:

1. Select the **Power** icon located on the bottom left of the screen.
If only 1 entertainment system is connected then the entertainment system will power off. If more than 1 entertainment system is connected then pop-over options are displayed allowing you to choose the entertainment system to turn off, or you can select **Power down all** to power off all connected systems.

Tip

Refer to the instructions provided with your entertainment system for details on naming your device. This aids device identification when multiple systems are connected.

18.4 Audio app menu options

Menu item	Description	Options
Tracks	Enables you to browse for tracks on USB/Bluetooth devices connected to your Entertainment system	<ul style="list-style-type: none">• Folder• Play Queue
Channels	Provides a list of available SiriusXM channels Note: For SiriusXM, channel control is not available from an external audio head unit.	Channel list
Stations	Provides a list of available Pandora stations	Station list
Audio sources	Enables you to select an audio source connected to your Entertainment system	<ul style="list-style-type: none">• AM Radio• FM Radio• Weather• Sirius XM• Pandora• Auxiliary• USB• Bluetooth• Airplay• S/PDIF

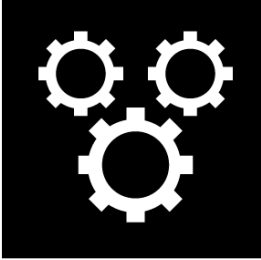
Menu item	Description	Options
Power	Enables you to Power your Entertainment system on and off	<ul style="list-style-type: none"> • On • Off
	Displays the Settings page	<ul style="list-style-type: none"> • Audio setting • Page settings

Audio app settings menu

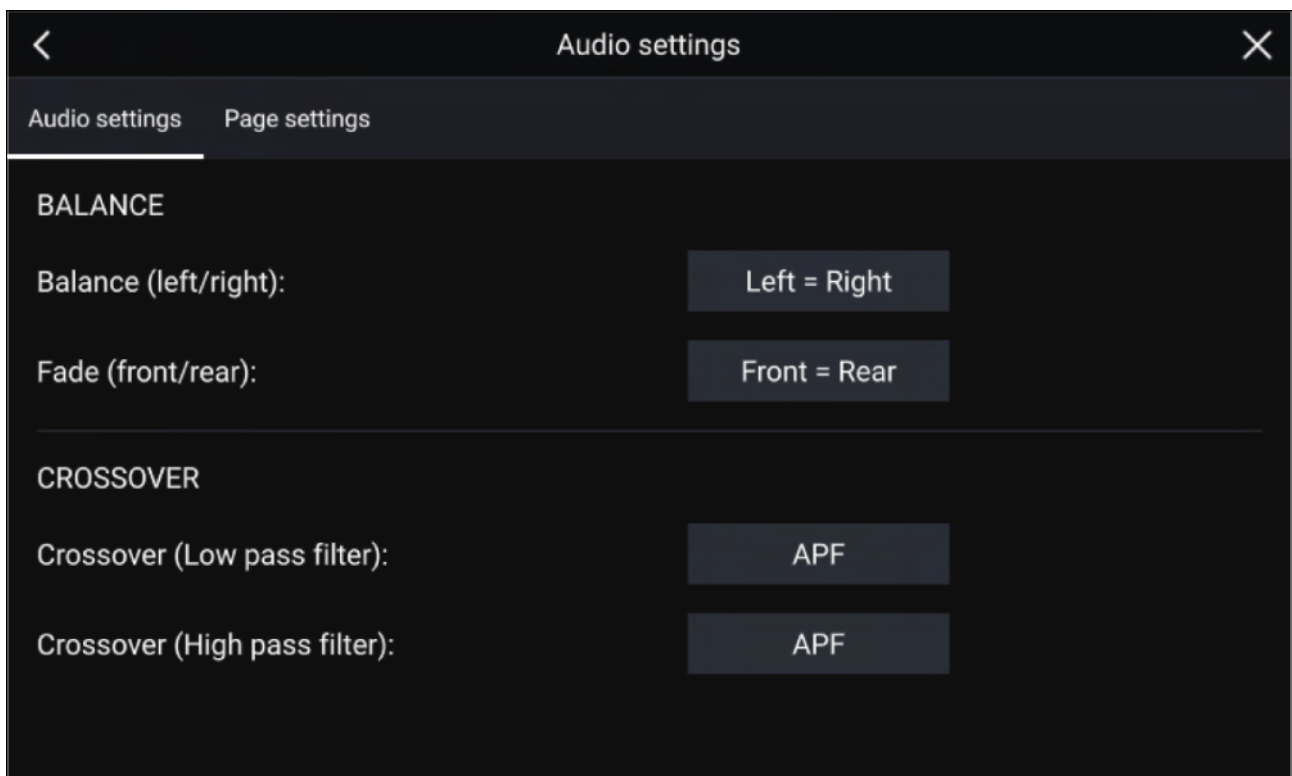

Audio settings tab

Menu item	Description	Options
Balance	Allows you to control the left / right speaker balance of your entertainment system speakers.	<ul style="list-style-type: none"> • L = Left speakers up to 100% • Left = Right (Balance centered) • R = Right speakers up to 100%
Fade	<p>Allows you to control the front / back speaker fade of your entertainment system speakers.</p> <p>Note: Only available on Rockford Fosgate entertainment systems.</p>	<ul style="list-style-type: none"> • F = Front speakers up to 100% • Front = Back (Fade centered) • R = Rear speakers up to 100%

Menu item	Description	Options
Crossover (Low pass filter):	Allows you to select the crossover frequency. The Low Pass Filter (LPF) will block all audio frequencies above the threshold you specify. Selecting APF (All Pass Filter) will allow all frequencies.	<ul style="list-style-type: none"> • 60 Hz • 80 Hz • 120 Hz • APF
Crossover (High pass filter):	Allows you to select the crossover frequency. The High Pass Filter (HPF) will block all audio frequencies below the threshold you specify. Selecting APF (All Pass Filter) will allow all frequencies.	<ul style="list-style-type: none"> • 60 Hz • 80 Hz • 120 Hz • APF
Multi-zone volume control:	Allows you to select independent audio zones that are controlled by multi-zone volume control. Note: Only available on Fusion audio devices with multi-zone control.	<ul style="list-style-type: none"> • Audio zones 1–12
Reset:	Performs a factory reset and power cycle of the SR200. Note: Only available on Sirius SR200 devices.	<ul style="list-style-type: none"> • Reset
Diagnostics mode:	Displays the SR200's diagnostic information. Note: Only available on Sirius SR200 devices.	<ul style="list-style-type: none"> • Display diagnostics

Page settings tab

Settings	Description
Data Overlays	Enables configuration of Data overlays
Edit split ratio	Enables you to customize the position of the partitions in splitscreen app pages.

Adjusting balance and fade controls

From the **Audio settings** menu: **Menu > Audio settings**

1. Select the **Balance** setting field or the **Fade** setting field.
The Adjustment slider control is displayed.

2. Place your finger on the White marker and then slide it left or right to adjust the setting the required value, alternatively use a **Rotary controller** to adjust the setting the required value.

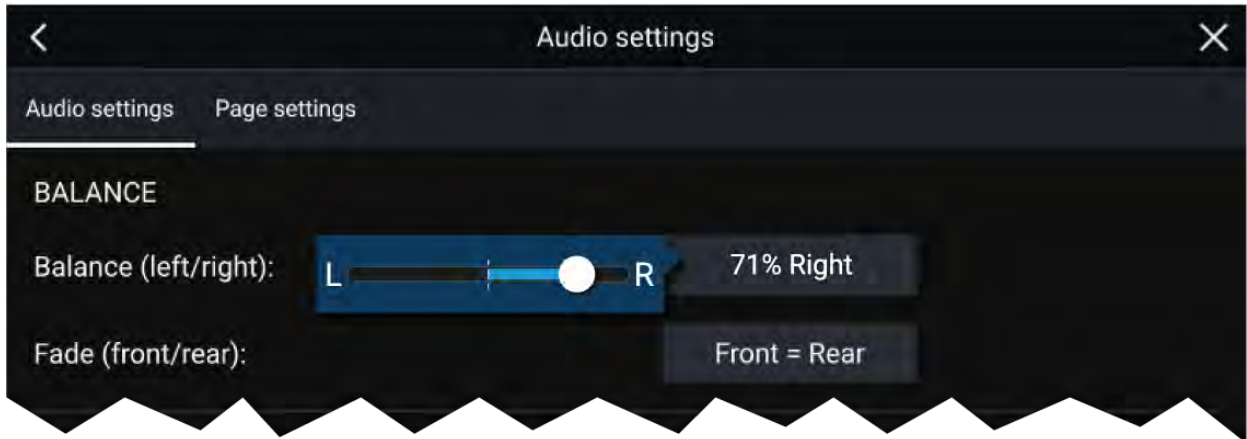

Note:

Fade controls are only available on Rockford Fosgate entertainment systems.

Adjusting multi-zone controls

From the **Audio settings** menu: **Menu > Audio settings**

1. You can choose which **audio zones** you want to change the volume of with **multi-zone control** by selecting them from the list.

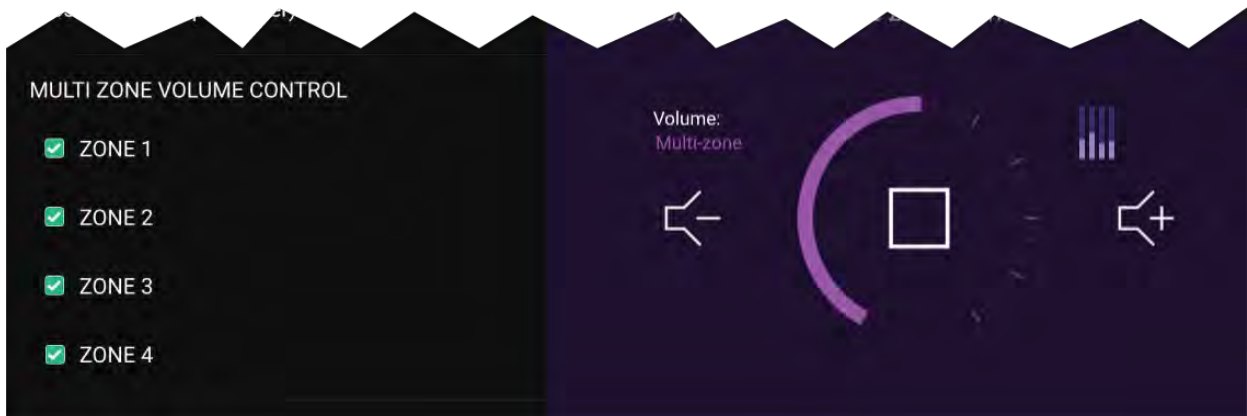

2. **Multi-zone volume** is adjusted from the Audio app home screen. Multi-zone volume control is enabled by pressing the multi-zone button (the volume dial will turn purple), all volume changes will affect audio zones selected from the **Audio settings**.

Note:

Multi-zone controls are only available on Fusion entertainment systems.

SR200 diagnostics mode

The SR200 diagnostic mode can be accessed from the audio settings menu from the master MFD on the network. The diagnostics mode should be referred to when liaising with Sirius product support.

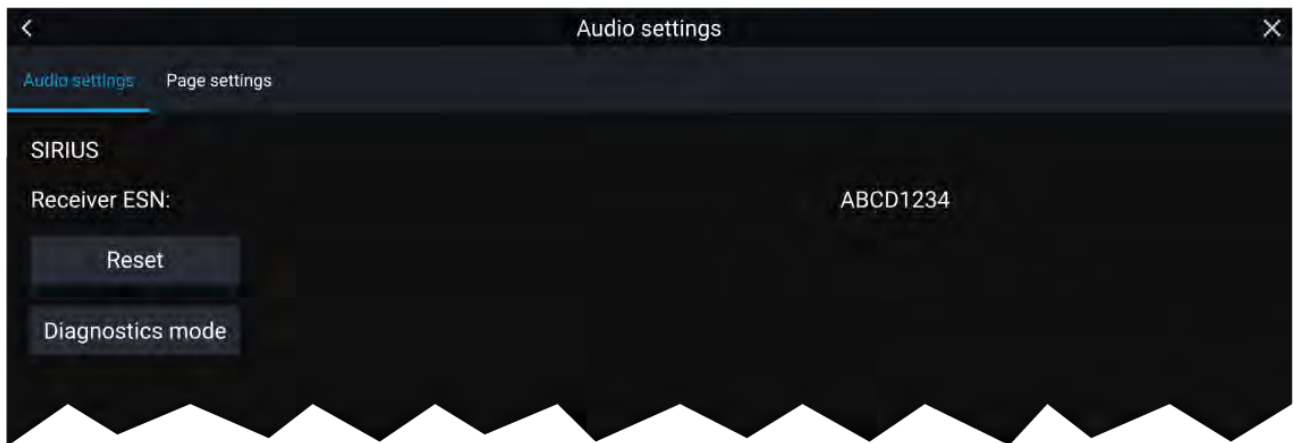

1. Reset — Performs a factory reset and power cycle of the SR200.
2. Diagnostics mode — Displays the SR200's diagnostic information.

Chapter 19: PDF Viewer app

Chapter contents

- [19.1 PDF Viewer app overview on page 370](#)
- [19.2 Opening PDF files on page 370](#)
- [19.3 PDF Viewer controls on page 371](#)
- [19.4 Searching a PDF on page 372](#)

19.1 PDF Viewer app overview

The PDF Viewer app can be used to browse and open PDF files located on your external storage device(s).

A typical use for the PDF viewer is to display Raymarine product handbooks that you have downloaded from the Raymarine website (www.raymarine.com/manuals). PDF files must first be copied to a MicroSD card using an external device (such as a PC or tablet). You can then insert the MicroSD card into your MFD's card slot, and access the PDF file(s) via the PDF Viewer app.

Note:

- The PDF Viewer app requires Lighthouse software version 3.10 or later.
- Secured PDF documents (encrypted with certificate or password) are not supported.

19.2 Opening PDF files

When opened, the PDF Viewer app allows you to browse PDF files available on your external storage device(s).

Select **Browse** to open a PDF file.

Recently-viewed files are displayed on the right-hand side of the initial app start screen, for quick access. These files can be opened, pinned to the top of the list, or removed from the list.

To access these options, long-hold touch on a filename to display the context menu.

Note:

- Recent files cannot be opened if the files are deleted or the external storage device is removed.
- A maximum of 15 of the most recent files can be shown in the pinned and unpinned recent files list.

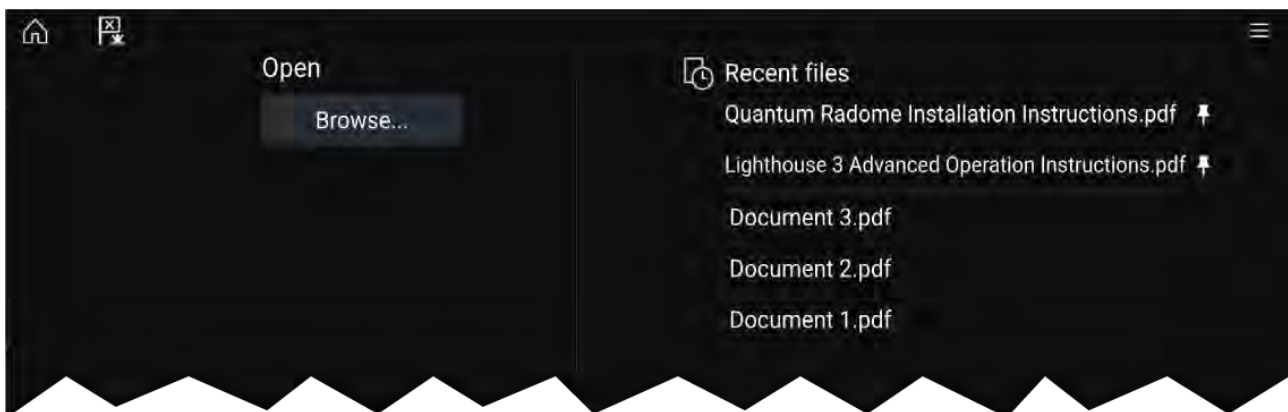

19.3 PDF Viewer controls

When a PDF file is displayed in the PDF Viewer app, the following options are available.

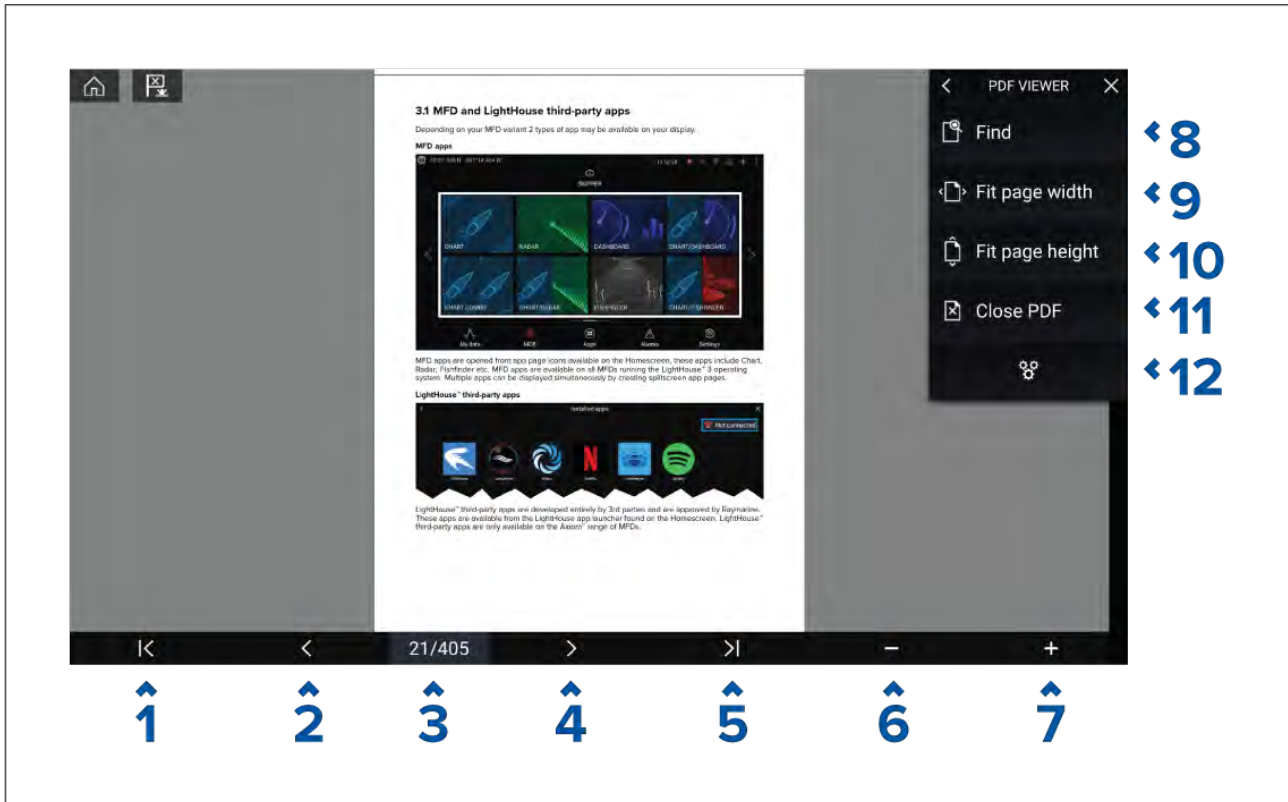

1. **First page** — Select to display the first page of the PDF document.
2. **Page back** — Select to display the previous page.
3. **Pages** — Indicates current page and total number of pages. You can also tap this element and enter a specific page number.
4. **Page forward** — Select to display the next page.
5. **Last page** — Select to display the last page of the PDF document.
6. **Zoom out** — Select to zoom out, in 10% increments.
7. **Zoom in** — Select to zoom in, in 10% increments.
8. **Find** — Select to display the onscreen keyboard and enter a search word or phrase.
9. **Fit page width** — Zoom the document display to fit the width of the PDF page.
10. **Fit page height** — Zoom the document display to fit the height of the PDF page.
11. **Close PDF** — Closes the PDF and displays the initial PDF Viewer app start screen.
12. **Settings** — Displays the Settings menu, which allows you to add data overlays to the PDF Viewer app.

19.4 Searching a PDF

You can search a PDF document for a word or phrase using the Find function.

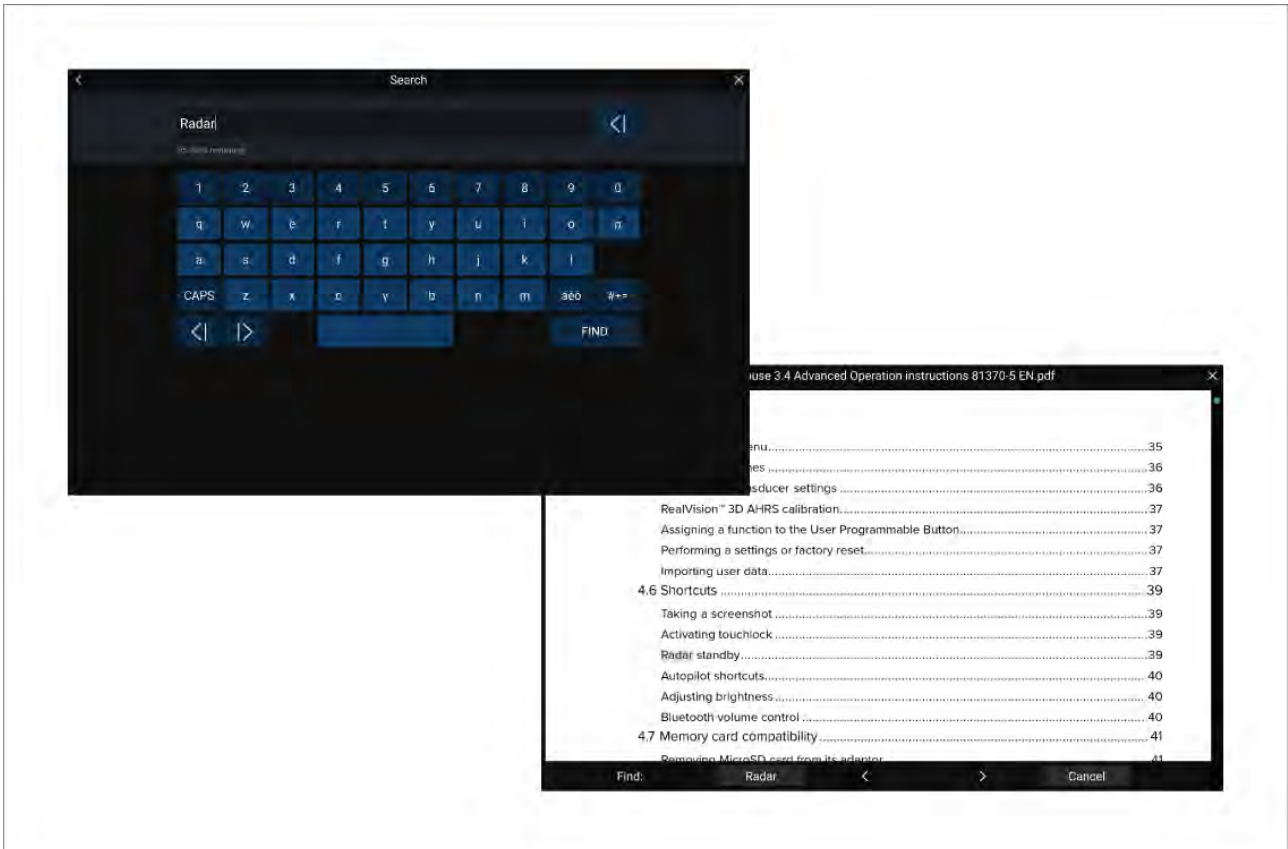

With the PDF displayed in the viewer:

1. Select **Find**.
2. Enter the word or search term.
3. Select **FIND**.

The document will scroll to the first occurrence of the searched term, which will be highlighted. Use the **Right arrow** and **Left arrow** controls to cycle to the previous or next occurrence of the search term. You can also search for another term by selecting **Find** and entering a new term, or you can cancel the find function by selecting **Cancel**.

Chapter 20: UAV (Unmanned Aerial Vehicle) app

Chapter contents

- 20.1 UAV disclaimer on page 374
- 20.2 UAV app overview on page 374
- 20.3 UAV pre-requisites on page 376
- 20.4 UAV precautions on page 378
- 20.5 Getting started on page 379
- 20.6 UAV app page on page 379
- 20.7 Opening the UAV app on page 380
- 20.8 Launching the UAV on page 382
- 20.9 Controlling the UAV in flight on page 382
- 20.10 Retrieving your UAV on page 383
- 20.11 Disconnect UAV remote controller from MFD on page 383
- 20.12 Fish on / Circle me mode on page 383
- 20.13 UAV Chart integration on page 384
- 20.14 UAV Emergency procedures on page 385

20.1 UAV disclaimer

The UAV app allows the FLIR multifunction display (“MFD”) to serve as an auxiliary controller for approved unmanned aerial vehicle (UAV) models. You are responsible for your own conduct while using the UAV and for any consequences thereof. You must use the UAV in accordance with all applicable legal regulations and safety recommendations of the UAV manufacturer. The primary controller should be readily accessible at all times while using the MFD as an auxiliary controller. FLIR accepts no liability for any damage, loss or injury caused by the UAV, whether caused by the use of the MFD or any other FLIR product. Particular attention must be paid to landing the UAV which must be done by the primary controller and not the MFD. By selecting continue, you confirm that you understand and accept these conditions.

20.2 UAV app overview

Axiom (Axiom™, Axiom™ Pro and Axiom™ XL) MFDs include the UAV (Unmanned Aerial Vehicle) app, which enables you to control a DJI Mavic Pro or Mavic Pro Platinum UAV using your MFD. The UAV app provides auxiliary remote controls, settings, video display and flight data for your connected UAV.

UAVs and MFDs have a one-to-one relationship, meaning that you can only control a UAV from the MFD that it is physically connected to. On an MFD network, each MFD can be connected to a different UAV, if required.

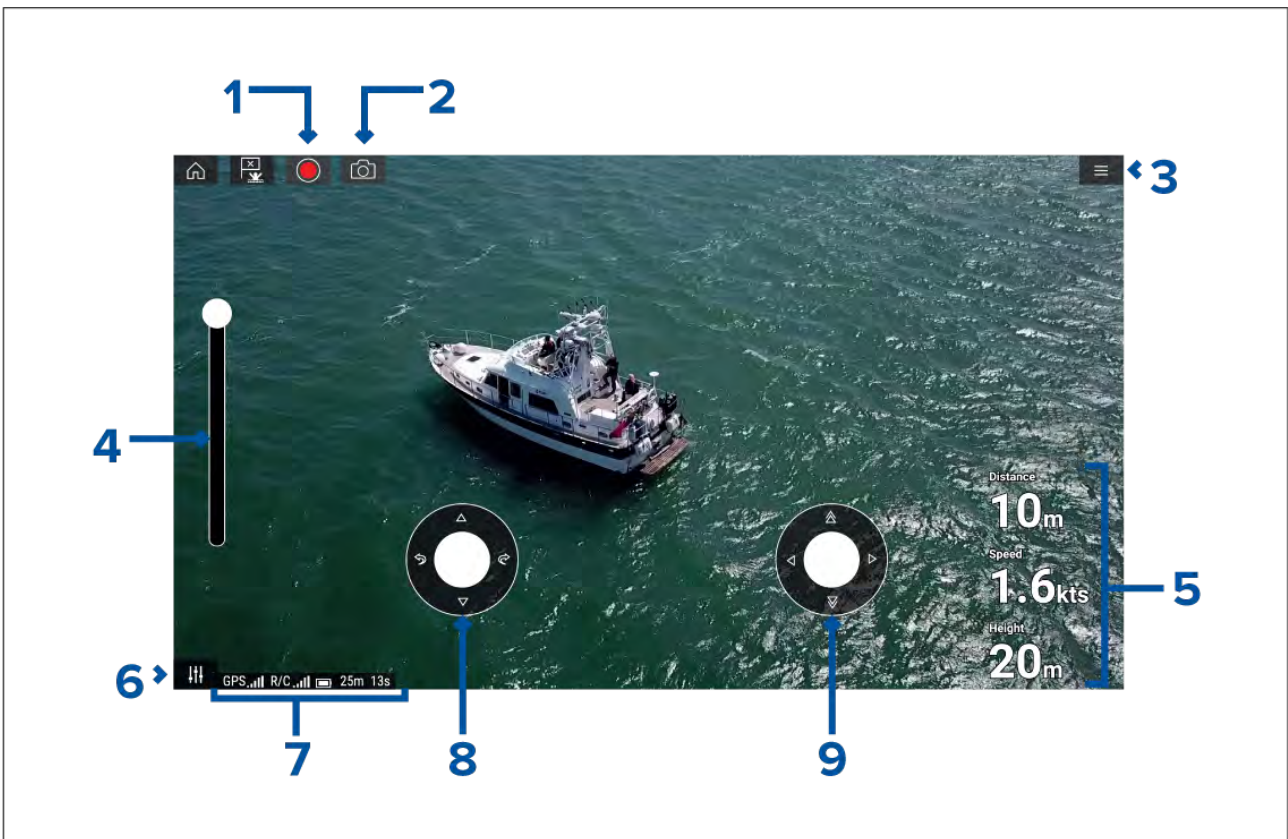

1	<p>Record Start recording your UAV’s video feed to a memory card inserted into the UAV’s memory card slot. While recording, the Record icon is replaced with a Stop icon and a time counter is displayed.</p>
2	<p>Take photo Take a screenshot of what is currently displayed in the UAV’s video feed. The image is saved to a memory card inserted into the UAV’s memory card slot.</p>
3	<p>Menu Opens the UAV app menu.</p>
4	<p>Gimbal pitch control Adjusts the pitch of the UAV’s camera gimbal, from pointing forwards (control at top of slider) to pointing straight down (control at bottom of slider).</p>

5	<p>Flight data Distance, Speed and Height data is displayed onscreen.</p> <p>Note: Displayed Flight data is specific to the UAV app and cannot be edited.</p>
6	<p>Controls Provides access to the onscreen virtual joystick controls.</p>
7	<p>Status area The status area provides the:</p> <ul style="list-style-type: none"> • signal strength of the UAV's GNSS (GPS) position fix. • signal strength from remote controller to UAV. • battery charge state. • flight time remaining. • identification of restricted no fly zones.
8	<p>Virtual joystick Provides Up, Down, Turn left and Turn right controls.</p>
9	<p>Virtual joystick Provides Forward, Backward, Move left and Move right controls.</p>

Note:

- The UAV app is not available on eS Series and gS Series MFDs.
- On an Axiom XL MFD the UAV connects to the same connection as a remote card reader. Therefore, on a standalone Axiom XL MFD installation, electronic cartography, via a chart card, will NOT be available at the same time as a connection to your UAV. Only pre-loaded world basemaps will be available in the Chart application.

Compatible UAVs

Currently the UAVs listed below are supported:

- Mavic Pro by DJI
- Mavic Pro Platinum by DJI
- Mavic 2 Pro by DJI
- Mavic 2 Zoom by DJI

Connection to any other UAV is not approved and is performed at your own risk.

UAV sport mode

When your UAV is in Sport mode (S-Mode), control via your MFD is limited.

In Sport mode the following MFD controls are disabled **virtual joystick**, **Gimbal pitch control**, **Take off**, **Return to boat** and **Fish on / Circle me**.

UAV app settings menu

You should check and configure the settings listed in the Advanced settings menu before attempting to operate your UAV.

Advanced

Settings	Description
Initial height after take-off:	Specifies the height at which the UAV will hover once it has taken off.
Minimum safe height during UAV goto:	Specifies the minimum safe height of the UAV when performing a Goto.

Settings	Description
Action if remote control signal is lost:	If your UAV loses connection to the remote controller then you can select whether your UAV Hovers in its current location or performs a Return to boat .
Minimum height:	Specifies the minimum height of the UAV when performing a Return to boat.
Return distance:	Specifies the distance from your vessel the UAV will reach when performing a Return to boat.
Height:	Specifies the initial height of the UAV when performing a Fish on / Circle me.
Distance:	Specifies the initial distance from your vessel when performing a Fish on / Circle me.

Page settings

Settings	Description
Data Overlays	Enables configuration of Data overlays
Edit split ratio	Enables you to customize the position of the partitions in splitscreen app pages.

Data overlays in the UAV app are separate from the Flight data information.

20.3 UAV pre-requisites

Before you can use the MFD's UAV app with your UAV you must have:

- set up your UAV in accordance with the instructions provided with the device.
- registered your UAV using the applicable DJI app (e.g.: **DJI GO 4**) on your mobile device.
- gained experience of launching, flying and retrieving your UAV.
- removed the RC cable from the side of your UAV's remote controller.
- ensured the remote controller is not in Sport mode.
- Created a UAV app page icon on the MFD's Homescreen.

Removing the RC cable

The RC cable used for connecting the UAV's primary controller to a mobile device must be removed, before connecting the controller to your MFD.

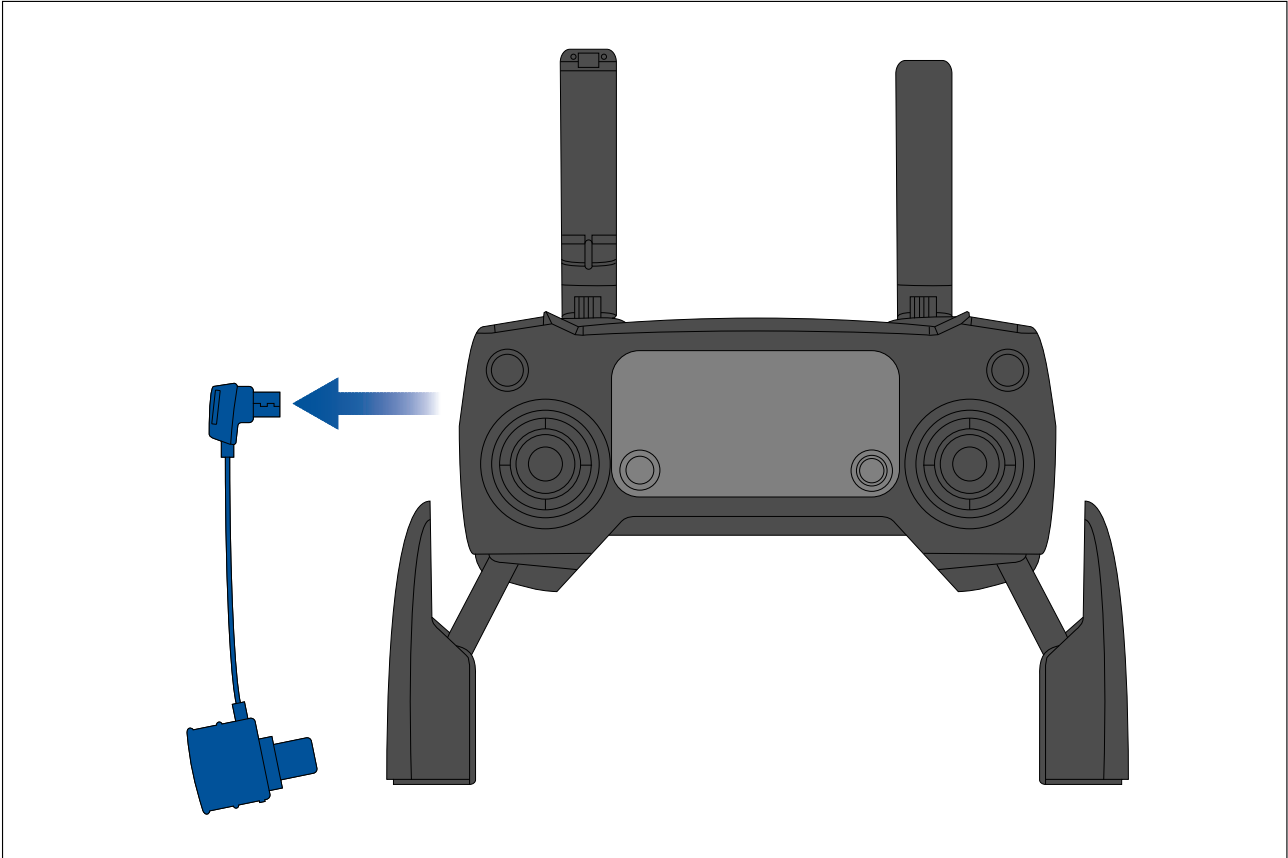

UAV controller connection

Your MFD's accessory connection must be connected to your UAV's primary remote controller using a USB "Micro B" to USB "A" cable.

Note:

- The UAV can NOT be connected to your MFD via the RCR-SDUSB. The card reader must be disconnected to enable connection to a UAV.
- The UAV can only be controlled by the MFD that the controller is connected to.

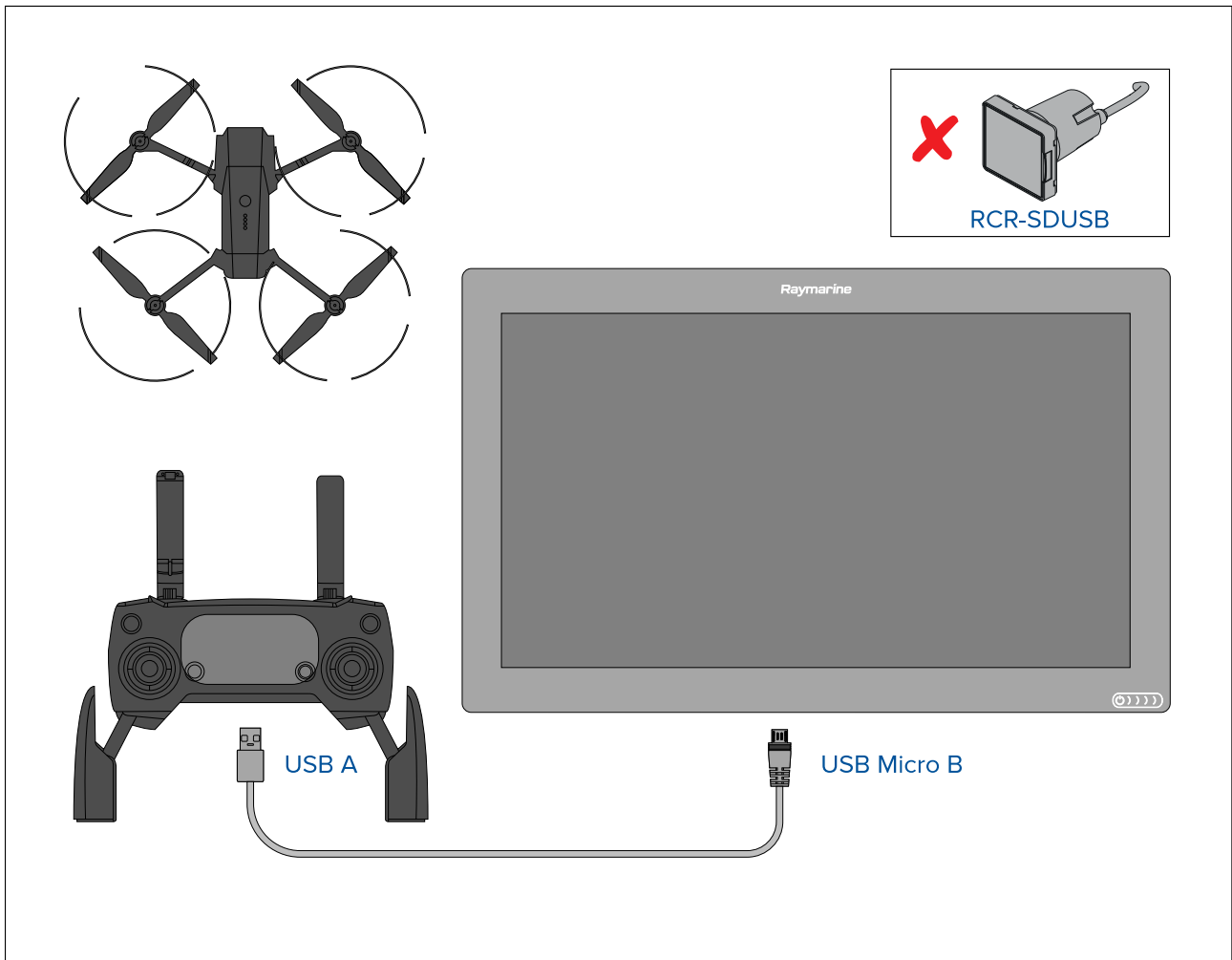

Important:

Ensure that the USB connection to your MFD is secure and protected against water ingress.

20.4 UAV precautions

Operating your UAV over water and launching and retrieving your UAV on a vessel can be a significantly different experience than when on land.

The following precautions should be followed:

- You will need to be an experienced, competent pilot as launching and retrieving the UAV on a vessel is more difficult due to confined space and vessel movement / drift.
- Only launch your UAV in calm wind and tide conditions. When attempting to launch or retrieve your UAV your vessel should be travelling at less than 1 knot and your captain should be ready at the helm to back down or maneuver the vessel to avoid accidental collisions
- Maintain awareness of your UAV's battery status, remaining flight time, distance from your vessel and Wind and Tide conditions. A UAV flying against the wind will consume battery power more rapidly than when flying downwind or in calm conditions. Always budget sufficient power reserves to ensure the safe return and retrieval of your UAV.
- Maintain a permanent watch of your UAV while in flight. The UAV pilot or competent observer must maintain awareness of surrounding air and marine traffic while the UAV is in flight. The pilot must remain ready to take control of the UAV and manually fly it to avoid interfering with other vessels or aircraft.
- While your UAV's controller is connected to your MFD it should be positioned so that it maintains line of sight with your airborne UAV. If the controller is not hand held then it must be secured to prevent it becoming disconnected from your MFD and to prevent unintentional button presses.

No-fly zones

It is illegal to fly your UAV in no-fly zones. No fly zones include:

- Airports
- Airfields
- Country borders
- Sensitive institutions

The Remote controller and the MFD will alert you that there is a no-fly zone. Your UAV will not enter the restricted airspace covered by a no-fly zone. You will also be unable to launch your UAV in restricted airspace. Please refer to the DJI app or the DJI website for more information on no-fly zones and their locations.

20.5 Getting started

Initial steps to get up and running with your UAV.

1. Using a **USB A to USB Micro B** cable, connect the Micro B end of the cable to the Accessory connection on the rear of your MFD.
2. Power on the MFD.
3. Obtain a GNSS (GPS) position fix on the MFD.
4. Open the UAV app.
5. Connect the MFD to the internet. (An internet connection is only required the first time you open the UAV app, after a Factory reset, or after an MFD software update).

Ensure that an internet connection is available on your MFD at the point of registration. If your vessel is likely to be out-of-range of cellular or satellite internet service at registration time, you will need to register the UAV before heading out on the water.

6. Wait for successful registration.
7. Power on the UAV's remote controller.
8. Power on the UAV.
9. Wait for the UAV to obtain a GNSS (GPS) position fix and for the "Ready to go" message to be displayed on the remote controller's screen.
10. Connect the USB A end of the USB cable to the relevant connection on the UAV's remote controller.

20.6 UAV app page

The UAV app is not displayed on the Homescreen by default. To open the UAV app you must first create a UAV app page icon on your MFD's Homescreen.

UAV control features are integrated with the Chart app; when creating a UAV app page it is recommended that you create a splitscreen Chart / UAV app page.

Follow the instructions detailed in the [5.4 Creating / Customizing an app page](#) section for information on creating an app page. Chart / UAV splitscreen app pages will be set to a 30/70 page split by default.

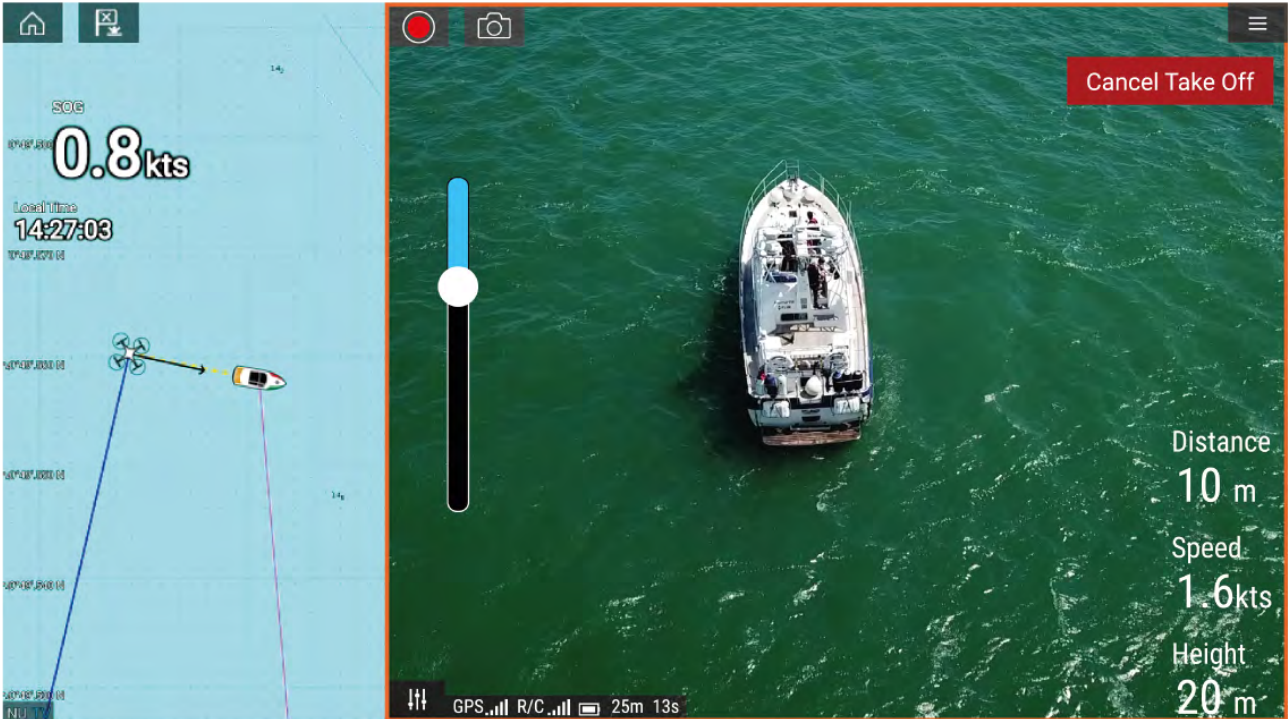

20.7 Opening the UAV app

The UAV app is opened from the Homescreen by selecting an app page icon that includes the UAV app.

The first time you open the UAV app and after each power cycle, a disclaimer is displayed. By selecting **Continue** you are agreeing to the terms of this disclaimer.

The UAV app will then open in 1 of 3 states:

No Wi-Fi connection



The first time you open the UAV app, after an MFD factory reset, or after you have updated your MFD's software, the UAV app must be registered using an internet connection on your MFD. Select **Wi-Fi Settings** to create an internet connection.



When registration is complete, if desired you can turn off your Wi-Fi connection by selecting **Wi-Fi Settings** and turning off your MFD's Wi-Fi. Selecting **OK** will close the info box keeping your Wi-Fi connection turned on.

Registration failed

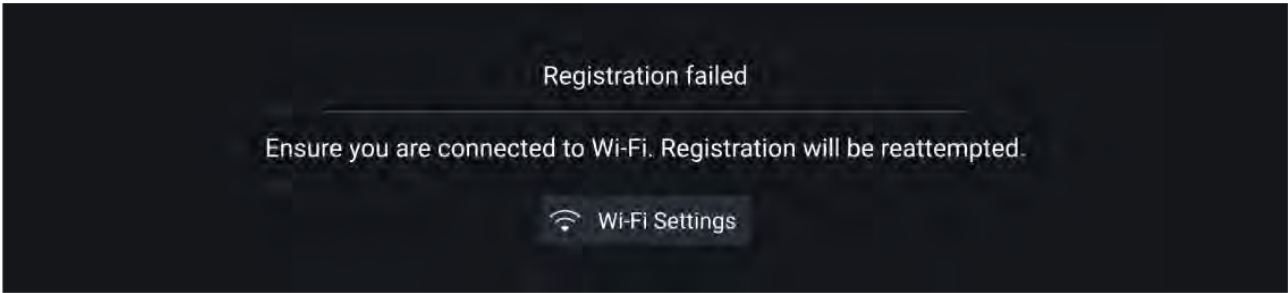

The registration failed notification is displayed if the DJI servers cannot be reached. Registration will be re-attempted automatically. If the failure persists, check your Wi-Fi and internet or try again later.

No connection detected



After successful registration, the 'No connection detected' notification is displayed. Connect the USB A end of your USB cable to the UAV's primary controller. Once a successful connection is established, the notification will be closed.

UAV app

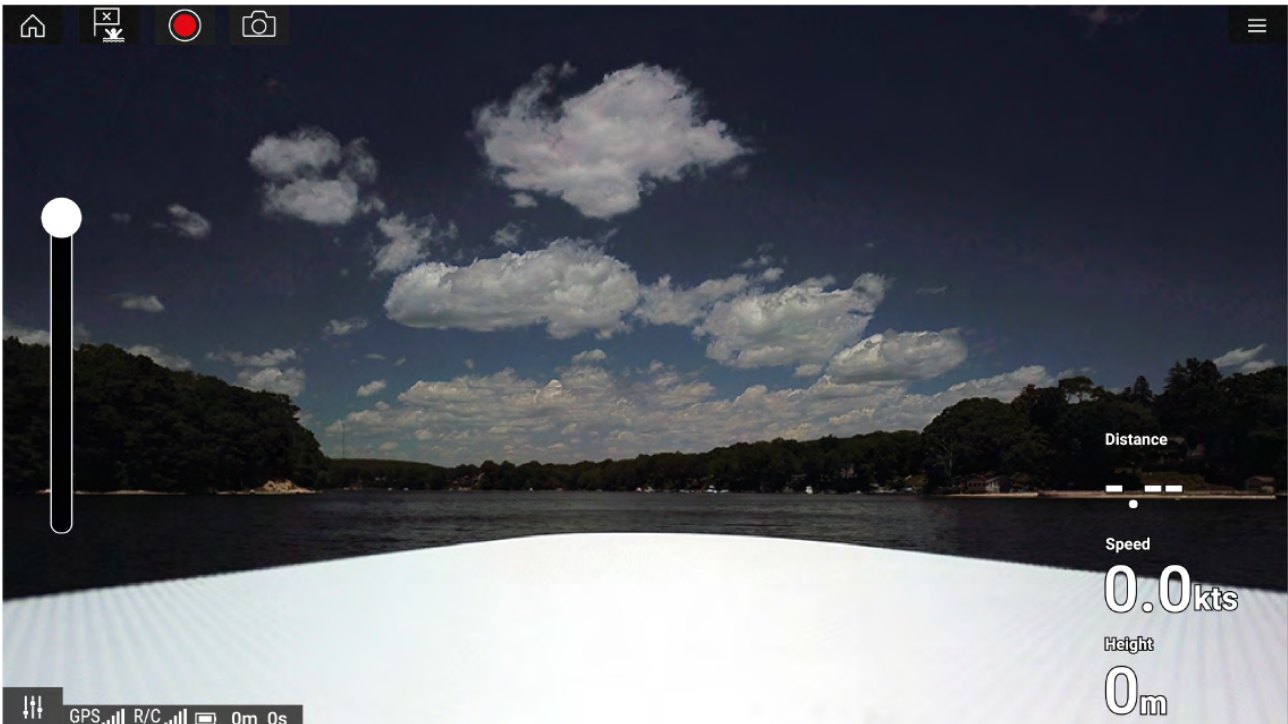

Once your UAV is correctly set up and connected to your MFD and your MFD's UAV app is registered successfully, the UAV's video feed is displayed and the app is ready to be used as an auxiliary controller for your UAV.

20.8 Launching the UAV

When it is safe to do so you can use the UAV app to launch your UAV.

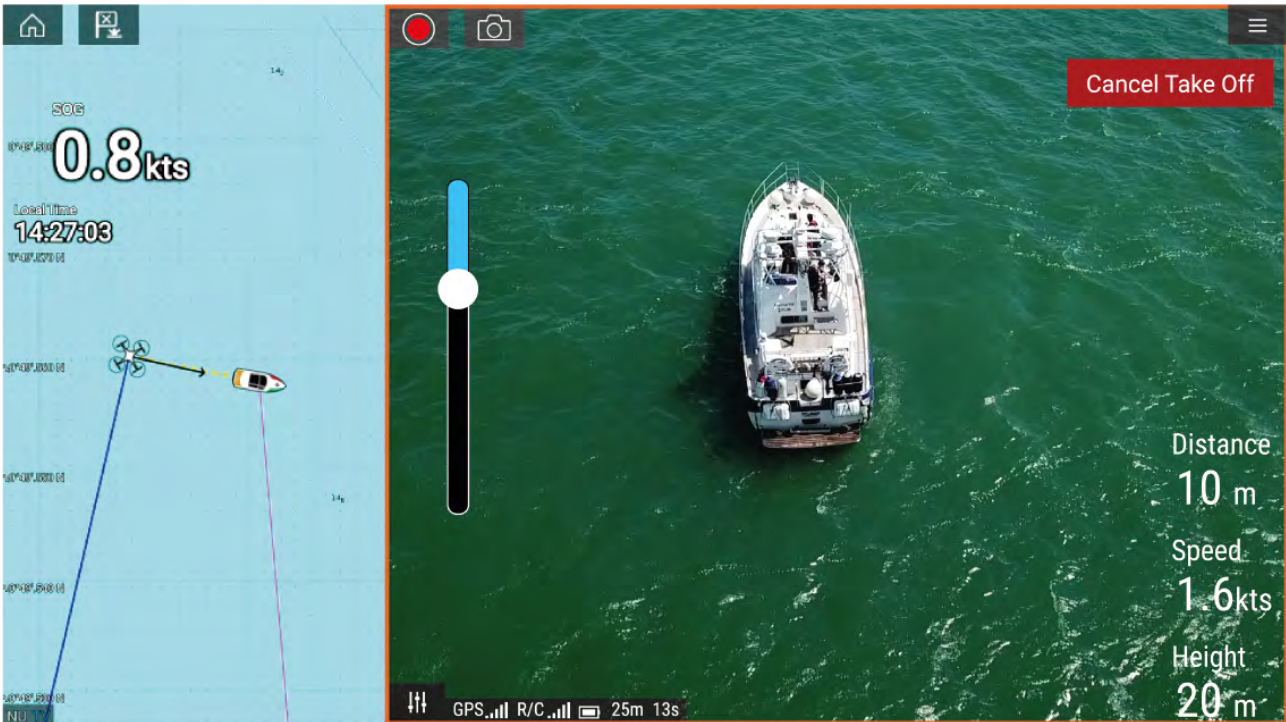

Prior to launch ensure that all necessary precautions have been taken to ensure no loss, damage or injury can occur.

1. Ensure your UAV is correctly connected and configured.
2. Ensure you have set an **Initial height after take-off**: in the appropriate Advanced settings menu: **Menu > Settings > Advanced > Initial height after take-off**:

Height needs to be sufficient so that your UAV will not collide with your vessel's sails, masts, rigging etc. or any other structure.

3. Place your UAV in an open space with sufficient room to launch unobstructed, taking into consideration the effects of wind direction and speed, tide direction and speed and the drift of your own vessel.
4. Select **Take off** from the UAV menu.
5. Select **Yes** to confirm take off.

The UAV will take off and lift to the height specified in step 2 above and hover.

The Take off can be cancelled at anytime by selecting the Red **Cancel Take Off** button. When **Cancel Take Off** is selected the UAV will stop and hover in its current position. If required, you can then use manual control to retrieve your UAV.

20.9 Controlling the UAV in flight

When in flight you can control the UAV using the onscreen virtual joysticks.

1. Select the **Controls** icon to display the **Virtual joysticks**.
2. The Virtual joysticks include controls for: **Up, Down, Turn left, Turn right, Forwards, Backwards, Move left and Move right**.
3. Use the **Gimbal pitch control** to move the UAV's camera to the required position.
4. If desired, use the **Record** and **Take photo** icons to record footage of your flight.

Note:

The Virtual joysticks take priority over your UAV's remote controller's joysticks, To use the remote controller's joysticks hide the Virtual joysticks by selecting the **Controls** icon.

20.10 Retrieving your UAV

To retrieve your UAV follow the instructions below:

1. Ensure that the **Minimum height** and **Return distance** settings are adequate for current conditions (Minimum height and Return distance can be adjusted from the Advanced settings menu: **Menu > Settings > Advanced**).
2. When you are ready to retrieve your UAV select the **Return to boat** option from the UAV app menu: **Menu > Return to boat**.

The UAV will return to your vessel's location within the specified Return distance and Minimum height, based on your MFD's current GNSS (GPS) position.

3. Once your UAV has reached the Return to boat position use the UAV's remote controller to manually retrieve your UAV safely.

Note:

The Return home manoeuvre can be cancelled at any time by selecting the Red, onscreen **Cancel return to boat** option. Once selected the UAV will stop and hover in its current position.

20.11 Disconnect UAV remote controller from MFD

When you have finished using the UAV app it is recommended that you disconnect the USB cable from the UAV's remote controller.

Before performing a MFD Factory reset, or software update, ensure that your UAV's remote controller is either powered off or disconnected from your MFD.

20.12 Fish on / Circle me mode

When Fish on / Circle me mode is activated your UAV will launch and circle your vessel, maintaining its camera's view on your vessel and recording the camera's video feed. Fish on / Circle me mode can also be initiated when your UAV is already in flight.

When your UAV is in Fish on / Circle me mode you should ensure your vessel speed does not exceed 10 knots or the UAV may not be able to keep up with your vessel. If your UAV cannot keep up slow your vessel speed.

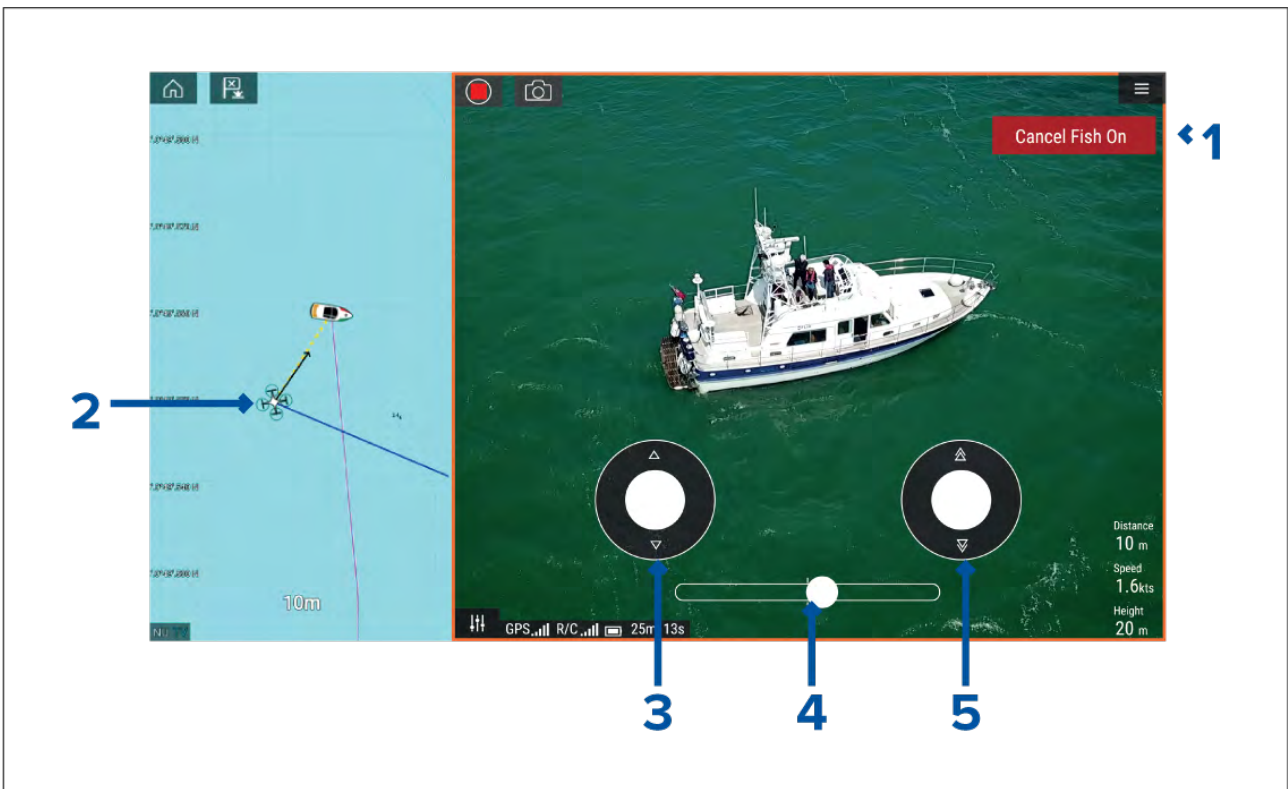

1	Cancel Fish On / Cancel Circle me Selecting Cancel Fish On / Cancel Circle me will stop Fish On / Circle me mode and the UAV will hover in its current location. If required you can manually stop recording by selecting the Stop icon.
2	UAV icon The UAV icon can be displayed in the Chart app. The icon includes a camera heading graphic, a Course Over Ground (COG) vector and a line linking your vessel icon to your UAV icon.
3	Virtual joystick In Fish On / Circle me mode the left virtual joystick provides Up and Down controls to adjust the UAV's distance from your vessel.
4	Rotation The Rotation slider control is used to adjust the UAV's direction of rotation and rotation speed. With the control on the slider center line the UAV will maintain position in relation to your vessel. Moving the slider right of the slider center line rotates the UAV counter-clockwise and moving the slider control to the left of the center line rotates the UAV clockwise. The farther left or right the slider control is set the faster the rotation speed will be.
5	Virtual joystick In Fish On / Circle me mode the right virtual joystick provides Forward and Backwards controls to adjust the UAV's height from your vessel.

Note:

During your initial MFD configuration the boating **Activity** you selected will determine whether the function is labelled **Fish on** or **Circle me**. If Fishing (freshwater), Fishing (saltwater) or Retail/demonstration is selected then the function is labelled **Fish on**, otherwise the function is labelled **Circle me**.

20.13 UAV Chart integration

When a compatible UAV with a GNSS (GPS) position fix is connected to your MFD, a UAV icon representing the position of the UAV is displayed in the Chart app.

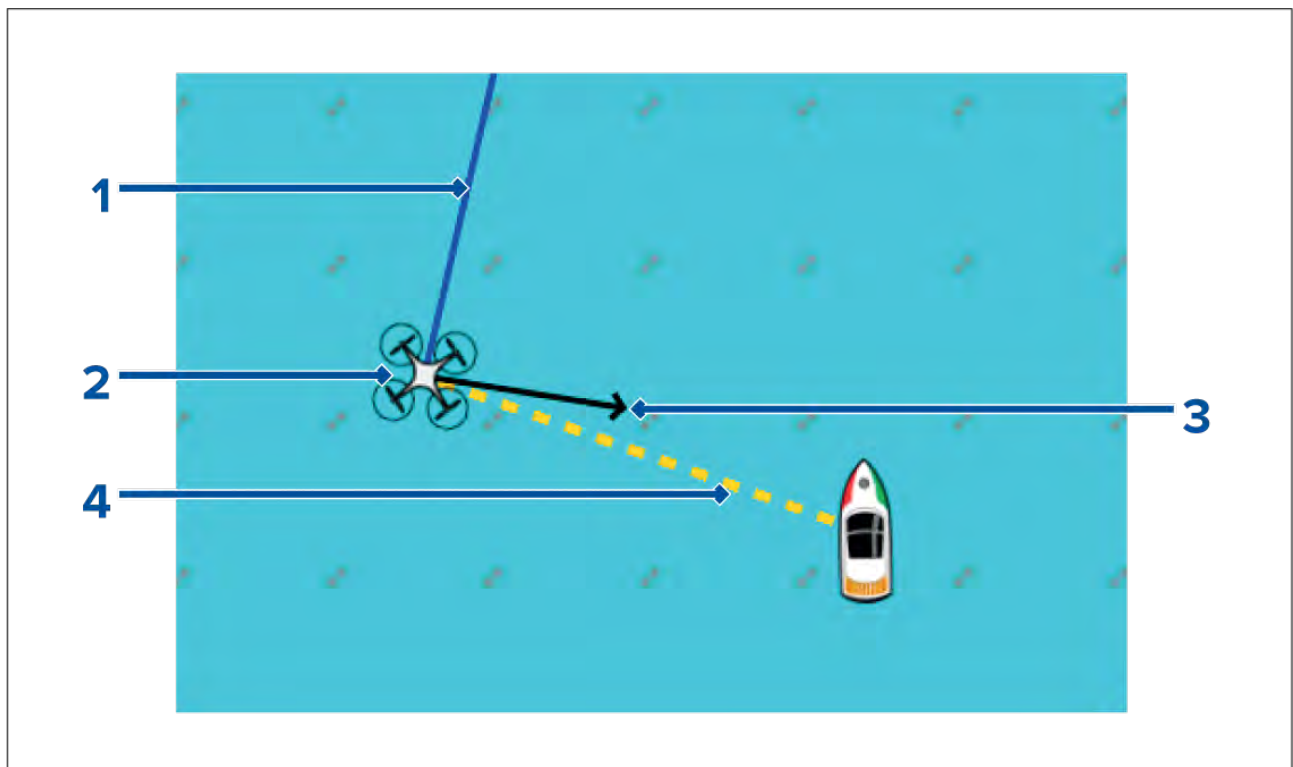

1	<p>UAV COG</p> <p>The direction of the Blue line indicates the UAV's current Course Over Ground (COG). The length of the line indicates the UAV's predicted position when the specified vector Reference period has passed.</p> <p>The Vector Reference period can be adjusted from the vessel icon's context menu.</p>
2	<p>UAV Icon</p> <p>Displayed when the UAV option is enabled in the Chart app settings, and your UAV has a GNSS (GPS) position fix.</p>
3	<p>Camera heading</p> <p>The Black Camera heading arrow is fixed to provide an indication of the direction the UAV's camera is pointing towards.</p>
4	<p>Line to vessel</p> <p>The Yellow dotted line represents the angle of the UAV's position relative to your vessel.</p>

Showing or hiding the UAV icon

The UAV icon is displayed by default in the Chart app. The icon can be hidden if required.

From the Chart app menu:

1. Select **Settings**.
2. Select the **Layers** tab.
3. Select the **UAV**: toggle switch.

Selecting the UAV toggle switch will make the UAV icon visible (on) or invisible (off).

Performing a UAV Goto

When your UAV is in flight you can select a location or object in the Chart app and perform a **UAV Goto** (your UAV will fly to the selected location or object and hover).

1. Select a location or object in the Chart app.

The Chart context menu is displayed.

2. Select **More**.
3. Select **UAV Goto**.

A UAV waypoint marker is placed to signify the UAV's destination and the UAV will fly to that location.

You can stop a UAV Goto at anytime by selecting the Red **Cancel UAV Goto** that is displayed onscreen in the UAV app, when a UAV Goto is active. Cancelling a UAV Goto will stop the Goto action and the UAV will hover in its current location.

A UAV Goto can be cancelled at any time by selecting **Stop UAV Goto** from the Chart context menu.

20.14 UAV Emergency procedures

The guidance below is intended to provide details of steps taken automatically by your UAV, and any manual intervention that may be required in certain situations.

Controller signal to UAV lost

In the event that your UAV loses its connection to the primary controller, the UAV will perform 1 of 2 actions, depending on your selection in the **Advanced** setting menu: **Menu > Settings > Advanced > Action if remote control signal lost**:

- **Hover** — The UAV will stop and hover in its current location. You should maneuver your vessel towards your UAV's position and attempt to re-establish control. When control is re-established it is recommended that you retrieve the UAV and inspect it immediately.
- **Return to boat** — The UAV will perform a Return to boat maneuver and hover at the **Return distance** and **Minimum height** specified in the Return to boat settings:
 - **Menu > Settings > Advanced > Minimum height**
 - **Menu > Settings > Advanced > Return distance**

If connection between the Remote controller and UAV is not re-established, your UAV will attempt to land.

Low battery warnings

Ensure while flying your UAV that you remain aware of the remaining flight time and distance from your vessel at all times. You must return your UAV to your vessel and safely retrieve it before a low battery warning occurs. The UAV app will mirror the UAV's primary controller battery state warnings.

- **Normal low battery level warning** — when the UAV reaches normal low battery level, in addition to the remote controller's audible and visual warnings a warning is also displayed on your MFD. You should immediately return the UAV to your vessel and retrieve.
- **Critical low battery warning** — when the UAV reaches critical low battery level, your UAV will automatically perform a **Return to boat** maneuver and attempt to land. It is not recommended that you allow your UAV to reach critical low battery while in flight, as it could result in damage or loss of your UAV.

Assuming manual control

The UAV pilot has the ability to take manual control of the UAV at any time. Manual control may be required for normal in-flight maneuvering or positioning, or in emergency situations. The methods of assuming manual control are as follows:

- Virtual joysticks will need to be hidden, using the **Controls** icon before control is returned to the Remote controller.
- Enabling Sport mode on the UAV's Remote controller at any time will override MFD controls. Fly with caution, as flight characteristics change in Sport mode.
- In an emergency, unplugging the USB cable from the Remote controller will override the MFD controls and immediately restore manual control to the Remote controller.

Chapter 21: LightHouse third-party apps

Chapter contents

- [21.1 LightHouse app launcher on page 388](#)
- [21.2 Lighthouse third-party apps - Preloaded on page 389](#)
- [21.3 Lighthouse third-party apps - Downloadable on page 391](#)
- [21.4 Installing Lighthouse third-party apps on page 391](#)
- [21.5 Internet connection on page 391](#)
- [21.6 Bluetooth speaker set up on page 393](#)

21.1 LightHouse app launcher

The app launcher provides a range of approved third-party apps on your MFD.

Important: The LightHouse app launcher and its associated third-party apps are not available on eS Series and gS Series MFDs.

Select **Apps** from the Homescreen to open the app launcher page.

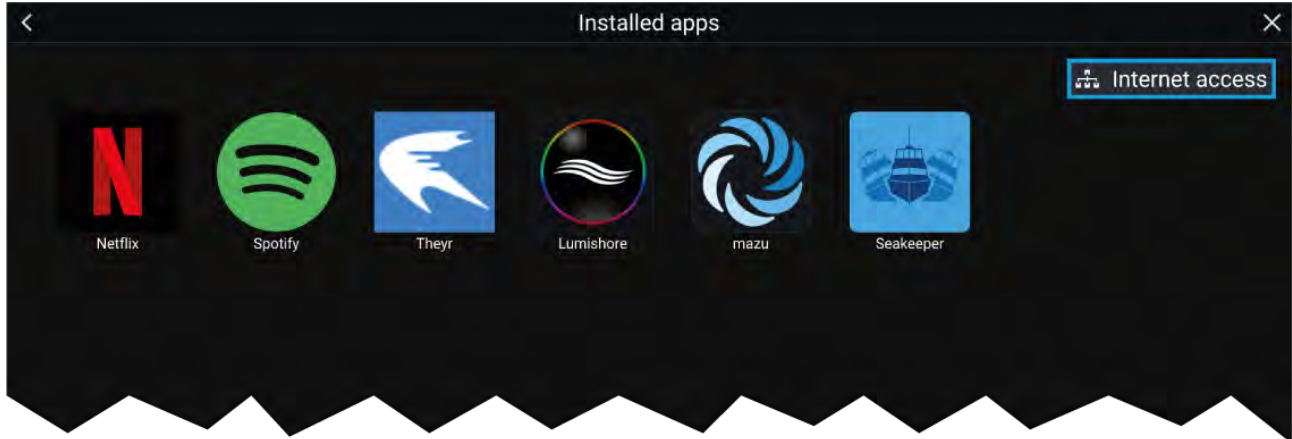

Selecting an app icon will launch the app. Selecting the Wi-Fi connection status button, located on the top right of the screen, will open the Wi-Fi connection settings to enable you to connect to the internet over Wi-Fi.

Apps may run in the background, enabling you to use your MFD as usual whilst, for instance, listening to music.

MFD alarms will be displayed and sounded as normal whilst using LightHouse third-party apps. When paired with a Bluetooth speaker, alarms will also be sounded through the speaker.

Bluetooth speaker volume can be controlled from the Shortcuts page or from the Status bar area on the Homescreen.

Note:

- Some app features or access to the apps may require your MFD to have an internet connection.
- If you use a wireless connection to a Quantum Radar, the Radar should be put in Standby before connecting your MFD to the internet.
- Some apps may also require an audio output. You can pair a Bluetooth speaker with your MFD to enable audio output.
- Raymarine does not provide support for third-party apps or any related third-party hardware. Please refer to the relevant third party app developer for assistance and troubleshooting.

LightHouse third-party apps

LightHouse™ third-party apps are apps that have been developed by third parties and approved for use on the LightHouse™ 3 operating system.

Note:

Raymarine does not provide support for third-party apps or any related third-party hardware. Please refer to the relevant third party app developer for assistance and troubleshooting.

Raymarine does not warrant that LightHouse™ third-party apps are error-free, and will not be held liable for damages or injuries caused by improper or inappropriate use of these apps.

















Warning: Maintain a permanent watch

Do NOT navigate whilst distracted by entertainment apps. Failure to maintain a permanent watch puts yourself, your vessel and others at serious risk of harm.

21.2 Lighthouse third-party apps - Preloaded

Below is a list of Lighthouse third-party apps preloaded to your MFD and details for each.

	<p>AnyDesk</p> <ul style="list-style-type: none"> • Requires Lighthouse Software version 3.13 or later. • Requires an internet connection. • Allows remote access to your MFD for troubleshooting and support purposes. • Refer to AnyDesk (www.anydesk.com) for details. <p>Attention</p> <ul style="list-style-type: none"> • AnyDesk is provided for troubleshooting and support purposes only, and is NOT intended to perform remote functions on your vessel. Raymarine will NOT be held liable for damage or injury to equipment or persons caused by the use of a remote connection to your MFD. • Do not disclose your AnyDesk ID to anyone other than authorised Raymarine Product Support personnel. • Do not use the AnyDesk app to remotely activate connected devices such as Autopilot, Radar or Sonar hardware.
	<p>GRIBview</p> <ul style="list-style-type: none"> • Requires Lighthouse Software version 3.4 or later. • Requires internet connection to download weather data directly to your MFD. Weather data can also be downloaded and placed on external storage for viewing at a later time (when your MFD has no internet connection available). • Log in using your existing Theyr subscription or register for free account directly from the app. <p>Note: It is not currently possible to log in to the app using an existing Raymarine LightHouse 2 subscription to Theyr weather.</p> <ul style="list-style-type: none"> • Refer to Theyr (www.theyr.com) for details.
	<p>HP Watermaker</p> <ul style="list-style-type: none"> • Requires Lighthouse Software version 3.12 or later. • Requires compatible RP TRONIC watermaker hardware. • Refer to HP Watermaker (www.hpwatermaker.it) for details.
	<p>Kinetix</p> <ul style="list-style-type: none"> • Requires Lighthouse Software version 3.12 or later. • Requires compatible Kinetix impact monitoring hardware. • Refer to Kinetix (https://kinetix.systems) for details.
	<p>Lumishore</p> <ul style="list-style-type: none"> • Requires Lighthouse Software version 3.5 or later. • Requires compatible Lumishore hardware. • Refer to Lumishore (www.lumishore.com) for details.
	<p>Lumitec</p> <ul style="list-style-type: none"> • Requires Lighthouse Software version 3.12 or later. • Requires compatible Lumitec Poco Digital Lighting Control hardware. • Refer to Lumitec (https://lumiteclighting.com/) for details.



	<p>Mazu</p> <ul style="list-style-type: none"> • Requires Lighthouse Software version 3.5 or later. • Requires compatible Mazu-marine hardware. • Refer to Mazu (www.mazu-marine.com) for details.
	<p>Netflix</p> <ul style="list-style-type: none"> • Requires Lighthouse Software version 3.4 or later. • Requires internet connection. • Log in using your existing subscription or join free for a month directly from the app. • Refer to Netflix (www.netflix.com) for details.
	<p>Oscar</p> <ul style="list-style-type: none"> • Requires Lighthouse Software version 3.13 or later. • Requires OSCAR collision avoidance camera. • Refer to Oscar: (www.oscar-navigation.com) for details.
	<p>Quick Nautical</p> <ul style="list-style-type: none"> • Requires Lighthouse Software version 3.12 or later. • Requires compatible Quick Nautical Network hardware. • Refer to QNN (https://www.quickitaly.com/) for details.
	<p>Seakeeper</p> <ul style="list-style-type: none"> • Requires Lighthouse Software version 3.7 or later. • Requires compatible Seakeeper hardware to be powered on and connected to the same network as your MFD. • Refer to Seakeeper (www.seakeeper.com) for details.
	<p>Shadow-Caster</p> <ul style="list-style-type: none"> • Requires Lighthouse Software version 3.10 or later. • Requires compatible Shadow-Caster hardware to be powered on and connected to the same network as your MFD. • Refer to Shadow-Caster (www.shadow-caster.com/) for details.
	<p>Spotify</p> <ul style="list-style-type: none"> • Requires Lighthouse Software version 3.4 or later. • Requires internet connection. • Log in using your existing subscription or join free directly from the app. • Refer to Spotify (www.spotify.com) for details.
	<p>Victron Energy</p> <ul style="list-style-type: none"> • Requires Lighthouse Software version 3.11 or later. • Requires compatible Victron Energy hardware to be powered on and connected to the same network as your MFD. • Refer to Victron Energy (https://www.victronenergy.com/markets/marine) for details.

21.3 Lighthouse third-party apps - Downloadable

Below is a list of Lighthouse third-party apps that can be downloaded to your MFD and details for each.

Note:

- Lighthouse third-party apps can be downloaded from: <http://www.raymarine.com/multifunction-displays/lighthouse3/lighthouse-apps/>
- For more information on installing Lighthouse third-party apps refer to: [p.391 – Installing Lighthouse third-party apps](#)

	<p>Buoyweather</p> <ul style="list-style-type: none">• Requires Lighthouse Software version 3.10 or later.• Requires internet connection.• Log in using your existing subscription or join directly from the app.• Refer to Buoyweather (http://www.buoyweather.com/) for details.
	<p>PredictWind</p> <ul style="list-style-type: none">• Requires Lighthouse Software version 3.10 or later.• Requires internet connection.• Log in using your existing subscription or join directly from the app.• Refer to PredictWind (https://www.predictwind.com/) for details.
	<p>Offshore</p> <ul style="list-style-type: none">• Requires Lighthouse Software version 3.10 or later.• Requires internet connection to download weather predictions. App can still display predictions if internet connectivity is lost. Weather predictions will update when internet connection is restored.• Log in using your existing subscription or join directly from the app.• Refer to PredictWind (https://www.predictwind.com/) for details.

21.4 Installing Lighthouse third-party apps

Additional Lighthouse third-party apps can be installed on your MFD via an SD card or USB.

Note: Only APK-approved Lighthouse third-party apps can be installed on your MFD. APK-approved Lighthouse third-party apps can be downloaded from: <http://www.raymarine.co.uk/lighthouse-apps/>

To install Lighthouse third-party apps:

1. Insert SD card or USB device into your MFD or external card reader.
2. From the **App Launcher** page, select **Install from SD / USB**.
3. Select the SD card or USB device that contains the third-party app file.
4. Select the APK file and it will automatically install on your MFD.
5. The app will be located on the **App Launcher** page.

Note: You can uninstall Lighthouse third-party apps from your MFD by long pressing them and selecting **uninstall**.

21.5 Internet connection

Connecting to the internet

From the Homescreen:

1. Select **Apps**.
The app launcher is displayed.
2. Select the Wi-Fi connection status button, located on the top right of the app launcher page.
The Wi-Fi settings page is displayed and will scan for available networks.
3. Select the relevant connection.
4. Enter the password for the network and select **Connect**.
Your MFD will now connect to the chosen network.
5. Select the **Back** triangle symbol or the **Home** Circle symbol at the bottom of the screen.
You can now use LightHouse™ apps that require an internet connection.

Wi-Fi settings

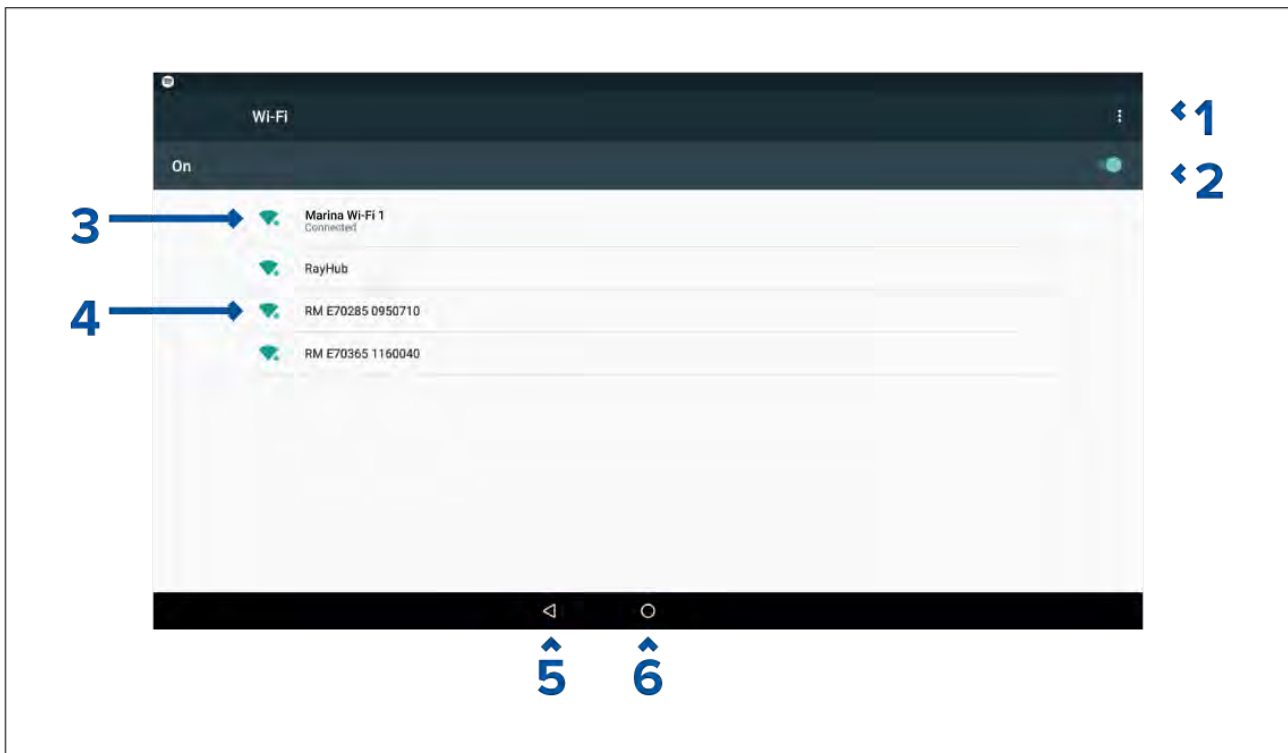

1. Wi-Fi options — Provides the following options:
 - Add network — Manually add a network.
 - Saved networks — View a list of all saved networks.
 - Refresh — Rescan available networks.
 - Advanced — View advanced network settings.
2. Enable/Disable Wi-Fi.
3. Connected access point.
4. Available access points.
5. Back button.
6. Home button

21.6 Bluetooth speaker set up

Enabling and disabling Bluetooth

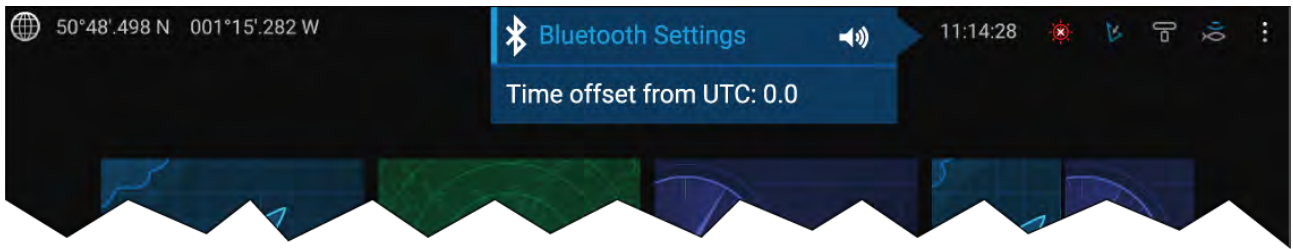

1. Select the Status bar area located in the top right of the screen.
2. Select **Bluetooth Settings**.
3. Select the Toggle switch on the right of the Bluetooth settings page to enable Bluetooth.

Alternatively the Bluetooth settings page can be accessed from the This display settings tab:
Homescreen > Settings > This display > Bluetooth > Bluetooth settings.

Bluetooth Settings

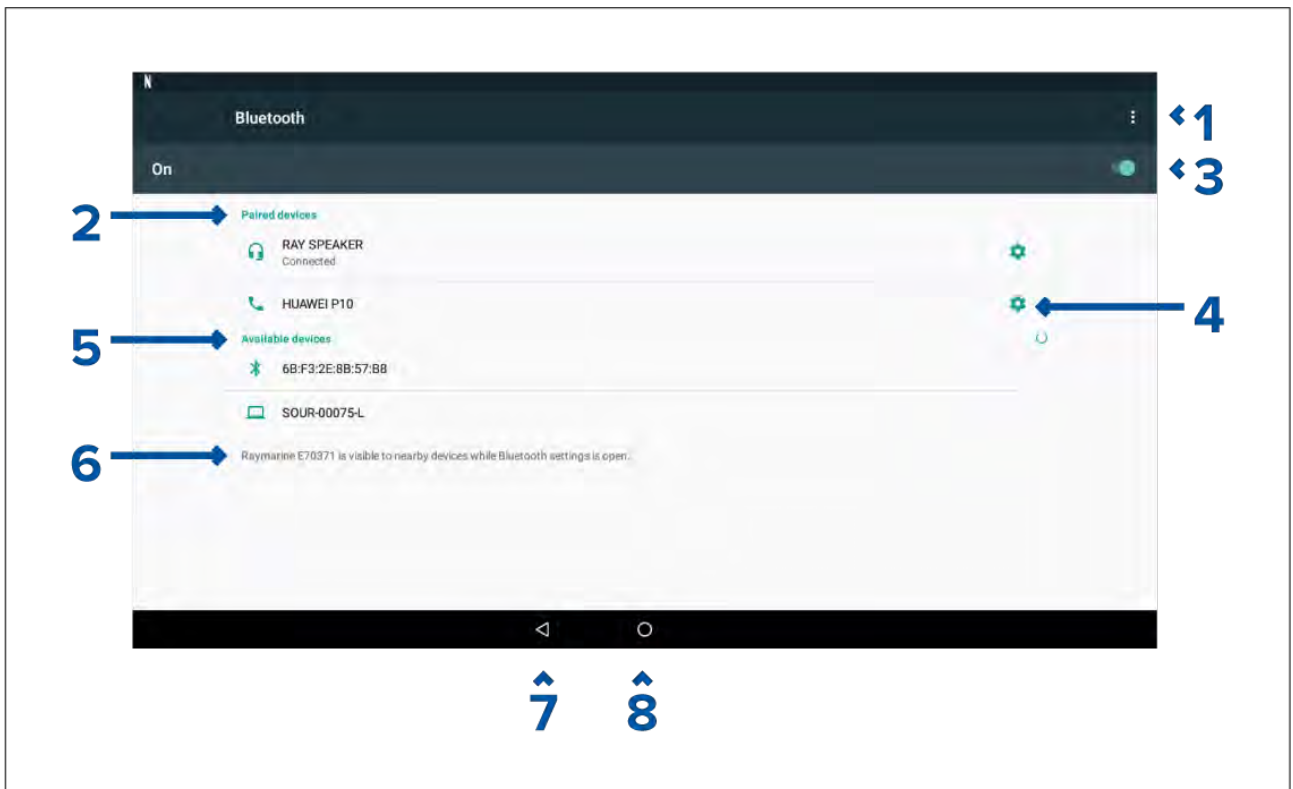

1. Bluetooth options — Provides the following options:
 - Refresh — Selecting refreshes the list of available devices.
 - Rename this device — Allows you to rename the Bluetooth name your MFD uses.
 - Show file received — Not used as your MFD cannot receive files over Bluetooth.
2. Paired devices — List of devices paired with your ~MFD.
3. Enable/Disable Bluetooth.
4. Paired device settings — Allows you to rename the paired device or forget the device.
5. Available devices — List of available Bluetooth devices.
6. MFD Bluetooth name.
7. Back button.
8. Home button.

Pairing a Bluetooth speaker

Before attempting to pair with a Bluetooth speaker, ensure that the speaker is switched on and discoverable.

With your MFD's Bluetooth enabled:

1. From the Bluetooth settings page, select the relevant device from the **Available devices** list.
2. If requested, confirm the bluetooth pairing code.

If pairing is successful the speaker will appear in the **Paired devices** list and display the **Connected** message.

Bluetooth volume control

When your MFD is connected to a Bluetooth speaker, controls will be available to adjust speaker volume.

Homescreen



From the Homescreen select the Status area and then select the Speaker symbol to display the Bluetooth volume control for LightHouse™ app and MFD alarms.

Shortcuts page

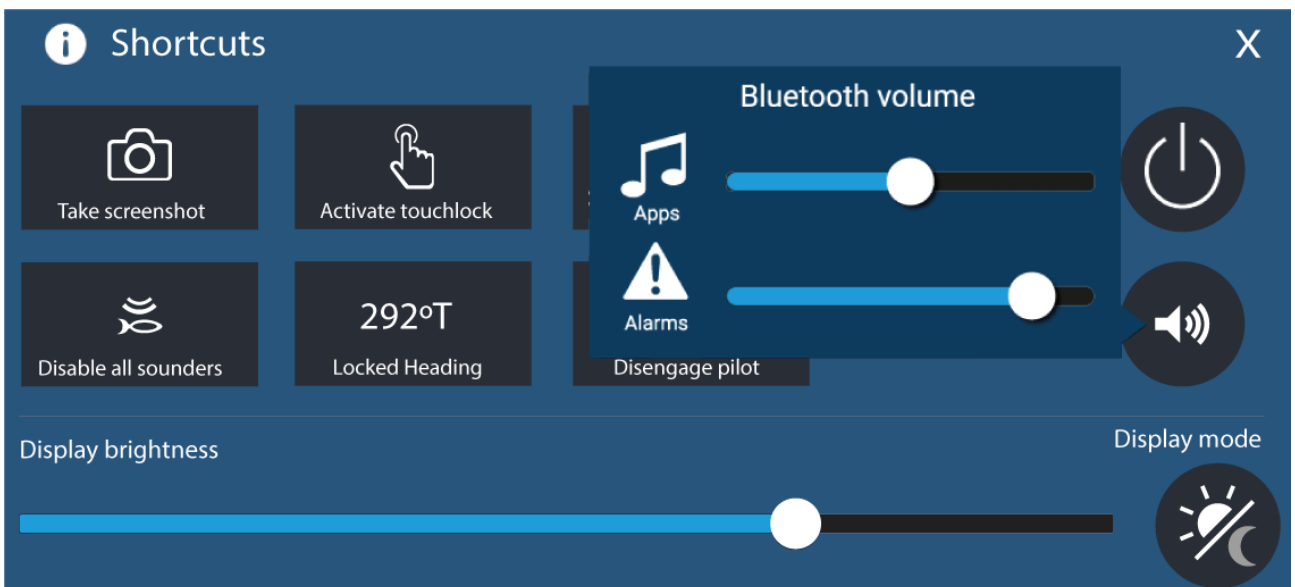

Press or swipe the **Power** button to display the Shortcuts page and then select the speaker symbol to display the Bluetooth volume control for LightHouse™ apps and MFD alarms.

Chapter 22: Mobile app support

Chapter contents

- [22.1 Raymarine mobile apps on page 396](#)
- [22.2 Connecting an Android device to the display on page 396](#)
- [22.3 Connecting an iOS device to the display on page 397](#)
- [22.4 RayConnect on page 397](#)
- [22.5 Fishidy sync on page 400](#)
- [22.6 Navionics plotter sync on page 402](#)
- [22.7 Controlling your MFD using RayControl on page 402](#)
- [22.8 Controlling your MFD using RayRemote on page 403](#)
- [22.9 Viewing your MFD screen using RayView on page 404](#)

22.1 Raymarine mobile apps

Please check the relevant app store for Raymarine mobile apps.

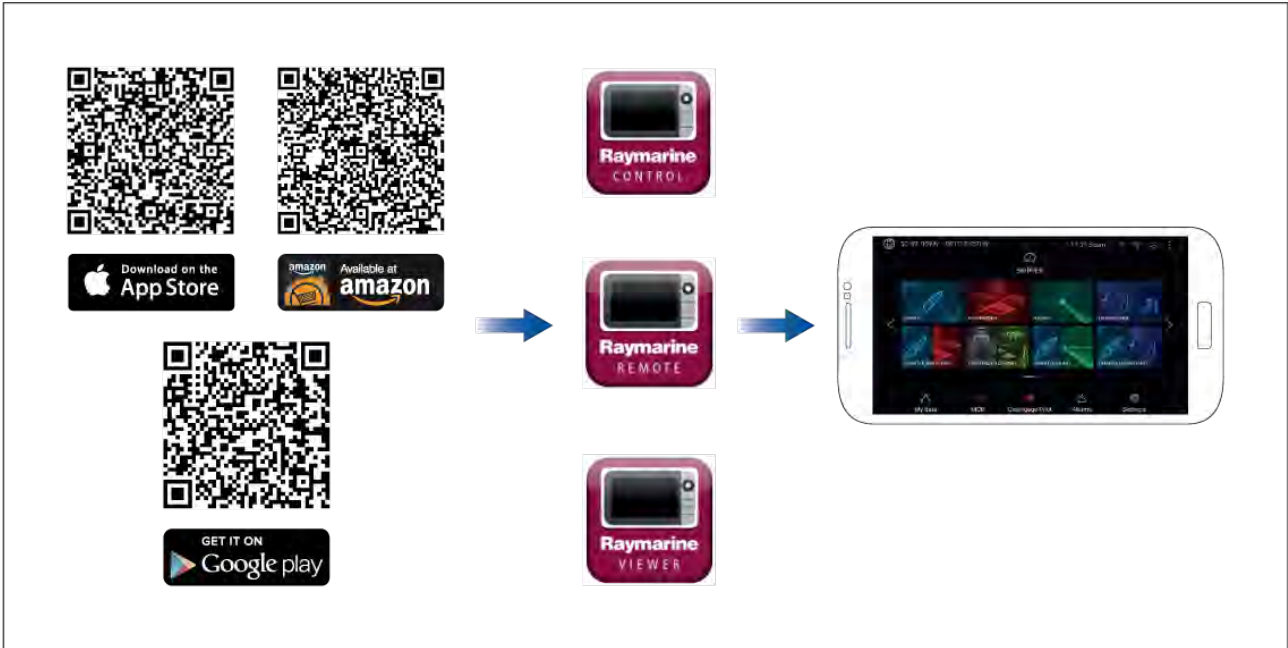

Note: When updating your MFD software ensure that you check for updates to your mobile apps.

22.2 Connecting an Android device to the display

Android devices can be connected to the display's Wi-Fi connection.

Open your Android device's Wi-Fi settings from the top drop down menu or via the **Settings** icon.

Example Android Wi-Fi connection

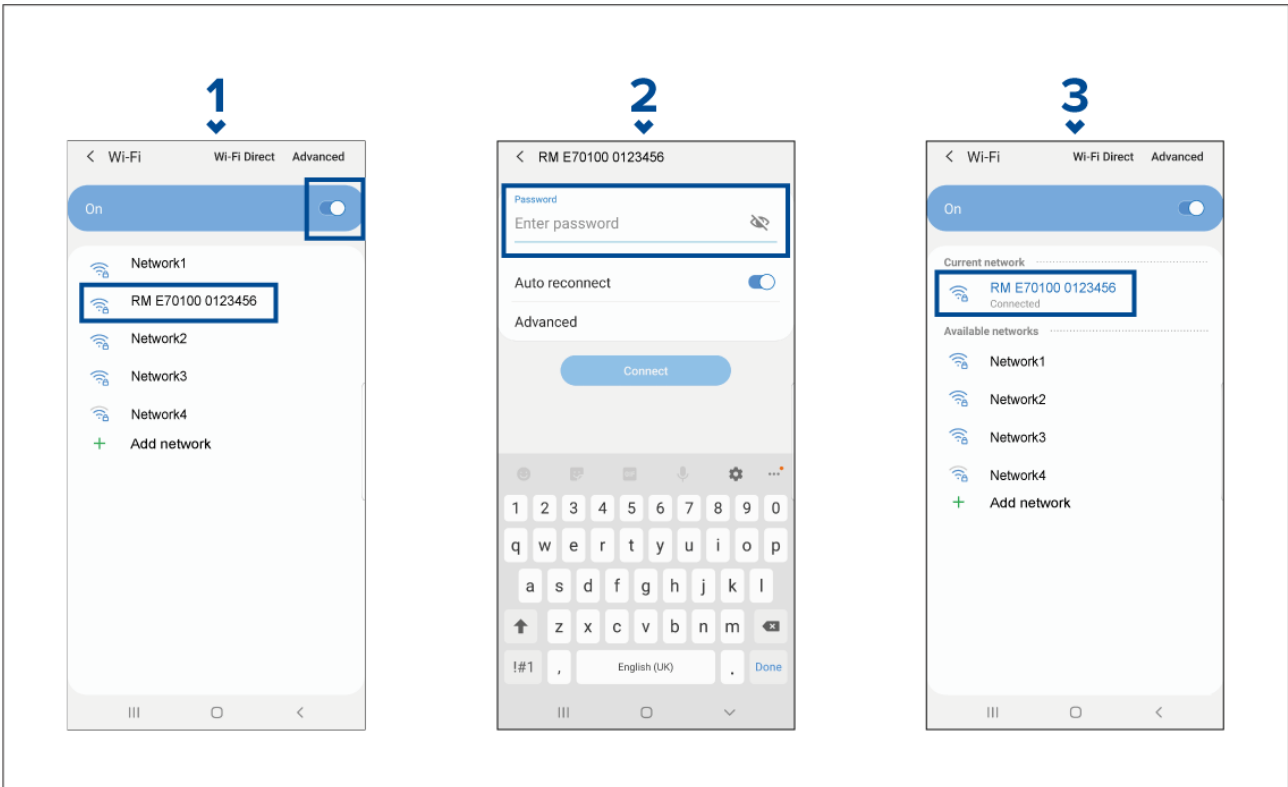

Note:

Depending on device type, manufacturer and version of the Android operating system in use, screens and options may be different than in the example above.

1. Enable Wi-Fi by setting the toggle to on (blue) and select your MFD from the available networks.
2. Enter your MFD's Wi-Fi passphrase and select **Connect**.

Make sure the password you enter is case sensitive.

3. When your Android device is connected to your MFD's Wi-Fi it will display connected under the MFD's name.

For troubleshooting advice refer to the Wi-Fi troubleshooting information on the Troubleshooting chapter [p.405 – Troubleshooting](#)

22.3 Connecting an iOS device to the display

iOS devices can be connected to the display's Wi-Fi connection.

Open your iOS device's Wi-Fi settings from the top drop down menu or via **Settings**.

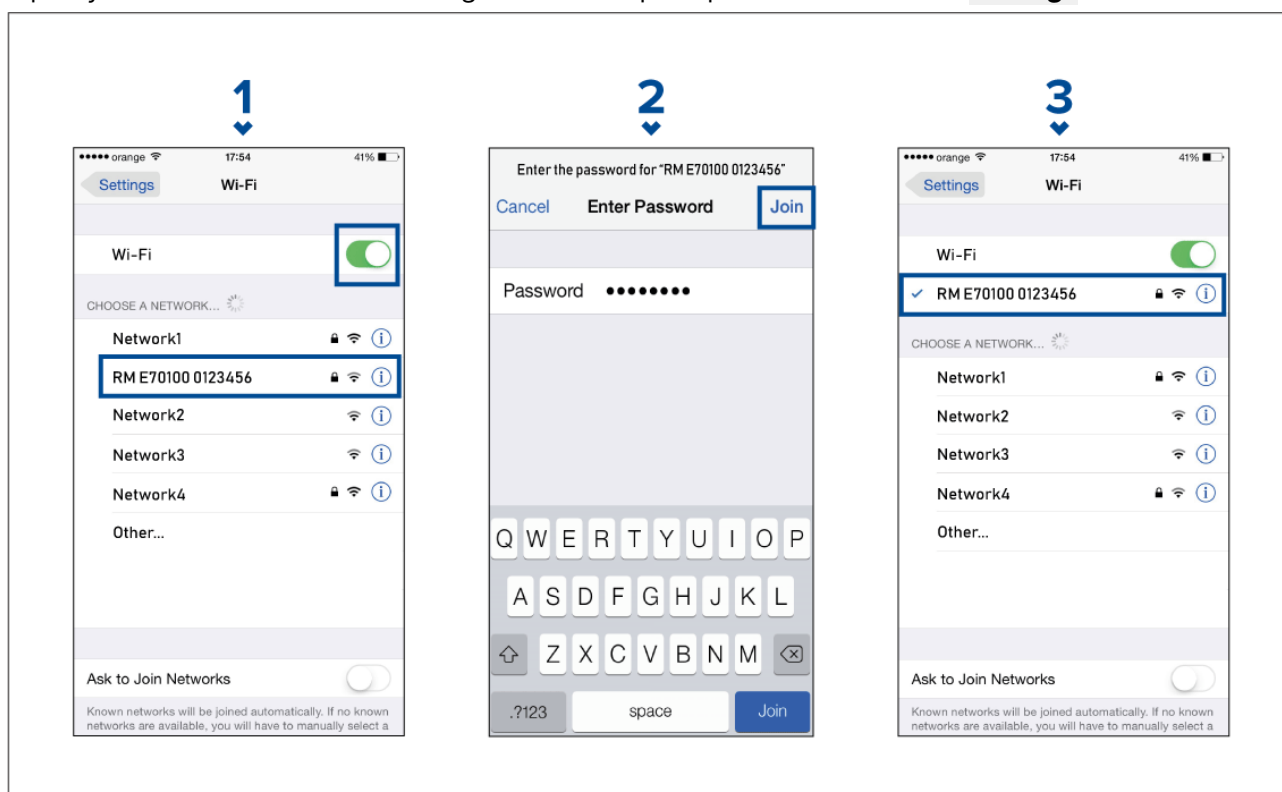

Note:

Depending on device type, and iOS version in use, screens and options may be different than in the example above.

1. Enable Wi-Fi by setting the toggle to on (green) and select your MFD from the available networks.
2. Enter your MFD's Wi-Fi passphrase and select join.

Make sure the password you enter is case sensitive.

3. When your iOS device is connected to your MFD's Wi-Fi it will display a tick next to the MFD's name.

For troubleshooting advice refer to the Wi-Fi troubleshooting information on the Troubleshooting chapter [p.405 – Troubleshooting](#)

22.4 RayConnect

Use the RayConnect app to purchase and download LightHouse Charts from the Chart Store.

Follow the steps below to use the RayConnect app:

1. Log in with an existing Raymarine account or create one using the app.

2. Purchase LightHouse Charts with the Chart Store.
3. Define the regions and types of cartographic data you want the chart to contain.
4. Download the charts to an SD card inserted in your Axiom™ or Element™ MFD, or download the chart data directly to an Axiom™ MFD's internal memory.

LightHouse charts

LightHouse™ charts is the brand name for Raymarine's electronic navigational charts. LightHouse™ charts can include a premium subscription which adds new and enhanced features.

Note:

Legacy LightHouse™ Vector, Raster and NC2 charts have now been discontinued and can no longer be downloaded or updated.

New LightHouse™ charts come with a free 1 year subscription to LightHouse™ Premium. The premium subscription unlocks data-rich points of interest (POI), high-resolution satellite aerial overlays and regular chart updates. After the free subscription ends the premium features can be continued for an annual fee.

LightHouse™ charts can be purchased from Raymarine dealers, as either a pre-loaded chart card or a blank chart card that includes a voucher that can be redeemed from the chart store.

To find out more about available regions and latest features visit the LightHouse™ charts store: <https://chartstore.raymarine.com/lighthouse-charts>

LightHouse Chart Store

LightHouse™ charts can be purchased from the LightHouse™ Chart Store, which can be accessed from a personal computer (PC) or from a mobile device via the RayConnect app.

You must have a Chart Store account and be logged in to the account before you can purchase charts in the Chart Store. This account can be created during the checkout process if required.

The screenshot shows the Raymarine LightHouse Chart Store interface. At the top, there is a navigation bar with the Raymarine logo, a 'CHART STORE' button, and a 'MY CHARTS' button. Below the navigation bar, there is a banner with the text 'Got a LightHouse Chart voucher?' and a 'Redeem voucher' button. The main content area is divided into two sections: 'Select charts by region' and 'Select charts from list'. The 'Select charts by region' section features a map of Europe and the Mediterranean with a red location pin over the United Kingdom. To the left of the map, it lists 'Lighthouse Chart - Great Britain and Ireland' for £145.00, including 12 months of Premium subscription free. The 'Select charts from list' section is currently empty.

Downloading charts using the RayConnect app

Purchased LightHouse™ charts can be downloaded to a MicroSD (μSD) memory card inserted into your MFD or to the internal storage of an Axiom™ MFD using a mobile device and the RayConnect app.

The following pre-requisites should be observed:

- If using mobile data, ensure you have sufficient data allowance remaining to prevent being charged.
- Ensure you have sufficient free space on your mobile device's internal storage for the charts to be downloaded to.
- Ensure that the memory card you want to use is formatted in the exFAT file system format (Chart cards purchased from the Raymarine chart store will arrive in this format).
- Ensure that the memory card has been inserted into the MFD's card reader prior to commencing the process (this will create the necessary Lighthouse_ID file in the card's root directory).
- A file named 'Lighthouse_charts' must be created in the memory card's root directory (Chart cards purchased from the Raymarine chart store will already include this folder).
- It is recommended that there are no other files on the memory card prior to downloading charts to it.
- Ensure **Allow devices to connect** is enabled in your MFD settings:
 - Element™ MFDs: **Homescreen > Settings > Wi-Fi.**
 - Axiom™ MFDs: **Homescreen > Settings > This display > Wi-Fi SHARING.**
- Part of the process involves connecting your mobile device's Wi-Fi to your MFD. For information on connecting your mobile device, refer to:
 - Android — [p.396 — Connecting an Android device to the display](#)
 - iOS — [p.397 — Connecting an iOS device to the display](#)

Note:

- Once a storage location (memory card or internal memory) has been chosen for your charts you cannot change it. Charts cannot subsequently be saved to a different card.
- Charts cannot be downloaded to the internal storage of Element™ MFDs.

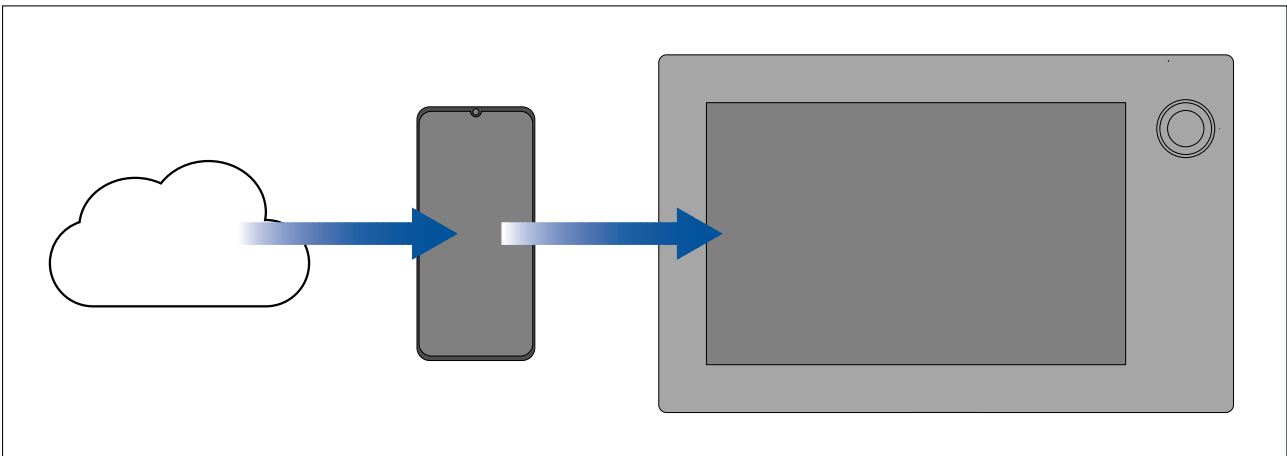

1. Install and open the RayConnect app from the relevant app store.
2. Create an account or Log in to the RayConnect app.
3. If requested select **ALLOW ONLY WHILE USING THE APP.**
4. Go to the **MY CHARTS** area.
5. Select the chart region you want to download.
6. If you have more than 1 region on the same continent in MY CHARTS, to minimize download file size, you can group up to 3 regions together.
7. If updates are available click **Get latest data.**
8. If you have a valid Premium subscription you can add **Streets & Points of Interest** and **Aerial photos** by clicking **Add now** next that you want to include.

*When adding **Streets & Points of Interest** and **Aerial photos** you can create up to 5 area boxes for each feature per purchased region. Follow the onscreen instructions to define each area of coverage.*

9. Select **Download** and then follow the onscreen instructions to download your charts to your MFD.

Account settings

You can edit your Raymarine account details using the **Account** menu.

You can edit the account's:

- Name
- Email address
- Password
- Region
- News and offers notification settings

22.5 Fishidy sync

You can synchronize Fishidy Spots and Waypoints between the Fishidy app and your MFD's Chart app.

Note:

Fishidy sync requires:

- Fishidy software version 6.1.0 or later.
- Lighthouse software version 3.11 or later.

Note:

Fishidy is currently available in:

- North America

Additional regions will become available in future Fishidy updates.



Enable sync

After connecting your mobile device to your MFD's Wi-Fi, you can begin syncing waypoints and Fishidy spots with the Fishidy app.

1. From the Fishidy app select **More**.

2. Select **Raymarine Sync**.
3. Select **Enable Sync** to begin synchronization between your Fishidy app and MFD.



4. When prompted by your MFD, select **Yes** to confirm sync.

*If you select **No**, sync will be cancelled and will need to be restarted.*

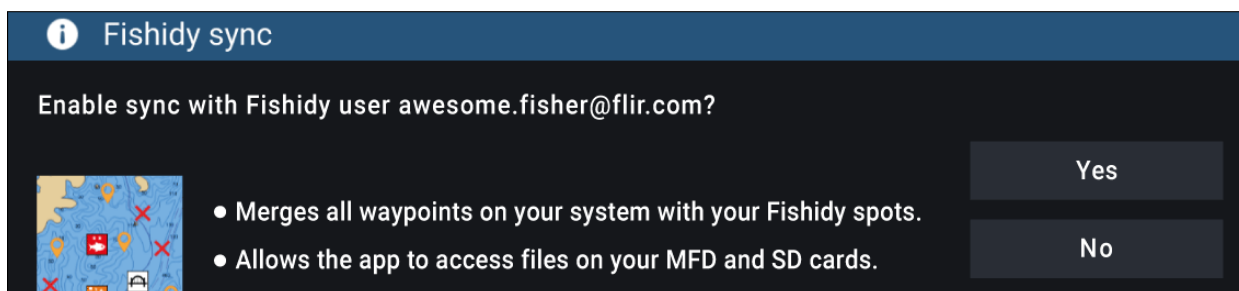

Once enabled, data will automatically sync in real-time across both devices via Wi-Fi.

Note:

- Fishidy Spots and Waypoints will be shared and can be interacted with from both devices.
- Your private waypoints remain private, whether viewing on Fishidy or your Raymarine MFD system.
- If you edit a Fishidy Spot or Waypoint on either device when sync is disabled (e.g. editing the name), re-enabling sync might place the item in the Fishidy **Recycle Bin**. In this scenario, the data can be restored from the recycling bin in the Fishidy app.
- Attempting to sync a new Fishidy account to your MFD while it is already synced with another account will prompt you to end sync with the first account. Ending sync with the first account and syncing the second account replaces any existing Fishidy Spots and Waypoints.

Disable sync

You can disable Fishidy sync from the Fishidy app or your MFD.

1. **Fishidy app**
 - i. Access the **Raymarine Sync** menu and select **Disable Sync**.
 - ii. **More > Raymarine Sync > Disable Sync**
2. **MFD**
 - i. Access the **My Data** page, select **Mobile sync** and select **Disable sync**.
 - ii. **Homescreen > My Data > Mobile sync > Disable sync**

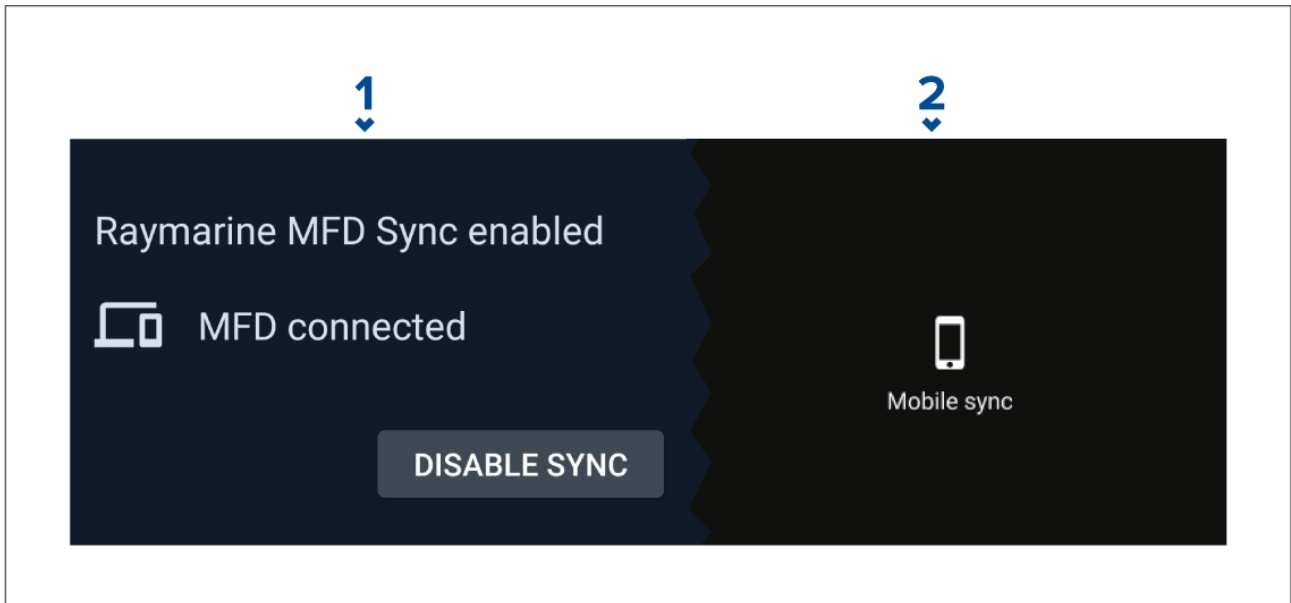

22.6 Navionics plotter sync

You can use the Navionics boating mobile app to:

- transfer waypoints and routes between your MFD and mobile device.
- update, activate and renew your Navionics cartography

22.7 Controlling your MFD using RayControl

The RayControl app allows you to remotely view and control your MFD from your mobile device.

1. Download and install RayControl from your app store.
2. Ensure your mobile device is connected to your MFD's Wi-Fi.
3. Open the RayControl app.
4. Control your MFD using your mobile device's touchscreen in the same way you would interact with the MFD's touchscreen.
5. You can also use a representation of an Axiom Pro's or RMK remote's physical buttons by sliding the controls sidebar out from the right of the screen or on smaller devices selecting **Remote Control**.

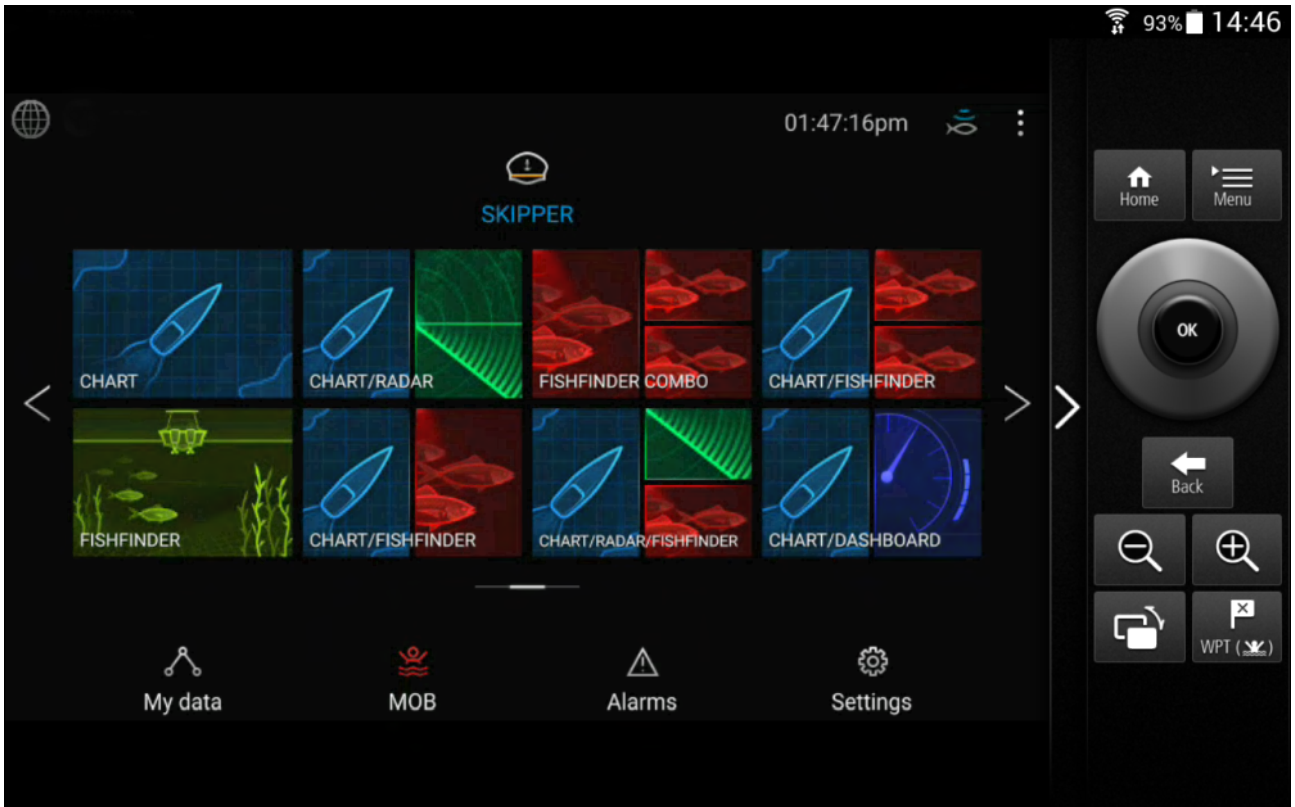

22.8 Controlling your MFD using RayRemote

The RayRemote app allows you to remotely control your MFD from your mobile device.



1. Download and install RayRemote from your app store.
2. Ensure your mobile device is connected to your MFD's Wi-Fi.
3. Open the RayRemote app.
4. Control your MFD on your mobile device using the on-screen equivalents of the physical buttons found on the Axiom Pro MFD or RMK remote keypad.

22.9 Viewing your MFD screen using RayView

The RayView app allows you to remotely view your MFD from your mobile device.

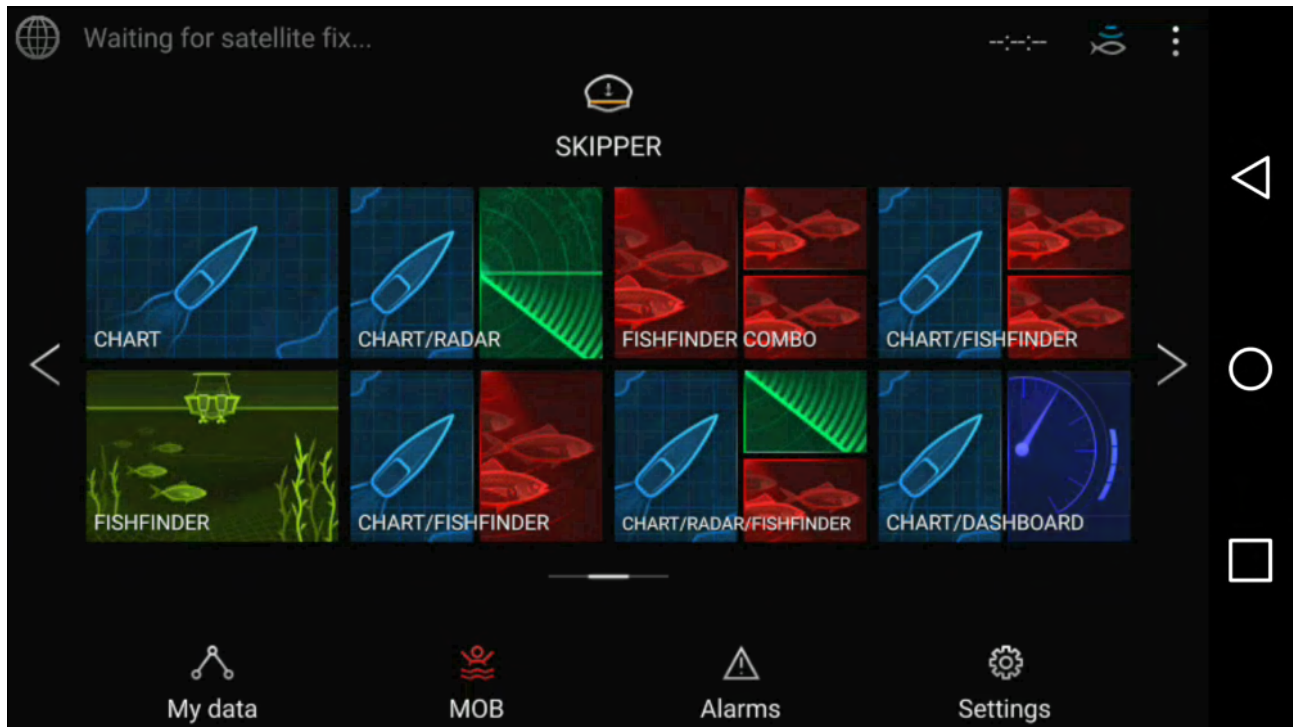

1. Download and install RayView from your app store.
2. Ensure your mobile device is connected to your MFD's Wi-Fi.
3. Open the RayView app.
4. Your mobile device's screen will now mirror your MFD's screen.

Chapter 23: Troubleshooting

Chapter contents

- [23.1 Troubleshooting on page 406](#)
- [23.2 Diagnostic product information on page 406](#)
- [23.3 Power up troubleshooting on page 407](#)
- [23.4 Radar troubleshooting on page 409](#)
- [23.5 GNSS \(GPS\) troubleshooting on page 410](#)
- [23.6 Sonar troubleshooting on page 410](#)
- [23.7 Camera troubleshooting on page 412](#)
- [23.8 Augmented Reality \(AR\) Troubleshooting on page 415](#)
- [23.9 Wi-Fi troubleshooting on page 416](#)
- [23.10 Wireless display troubleshooting on page 418](#)
- [23.11 Data troubleshooting on page 419](#)
- [23.12 Touchscreen troubleshooting on page 419](#)

23.1 Troubleshooting

The troubleshooting information provides possible causes and corrective action required for common problems associated with installation and operation of your product.

Before packing and shipping, all Raymarine products are subjected to comprehensive testing and quality assurance programs. If you do experience problems with your product this section will help you to diagnose and correct problems in order to restore normal operation.

If after referring to this section you are still having problems with your product, please refer to the Technical support section of this manual for useful links and Raymarine Product Support contact details.

23.2 Diagnostic product information

Diagnostic product information can be viewed from your MFD, for products networked using SeaTalkhs® and SeaTalkng® / NMEA 2000.

To view diagnostic product information, select **View all product info** from the **Diagnostics** pop over menu: **Homescreen > Settings > Network > Diagnostics > View all product info**.

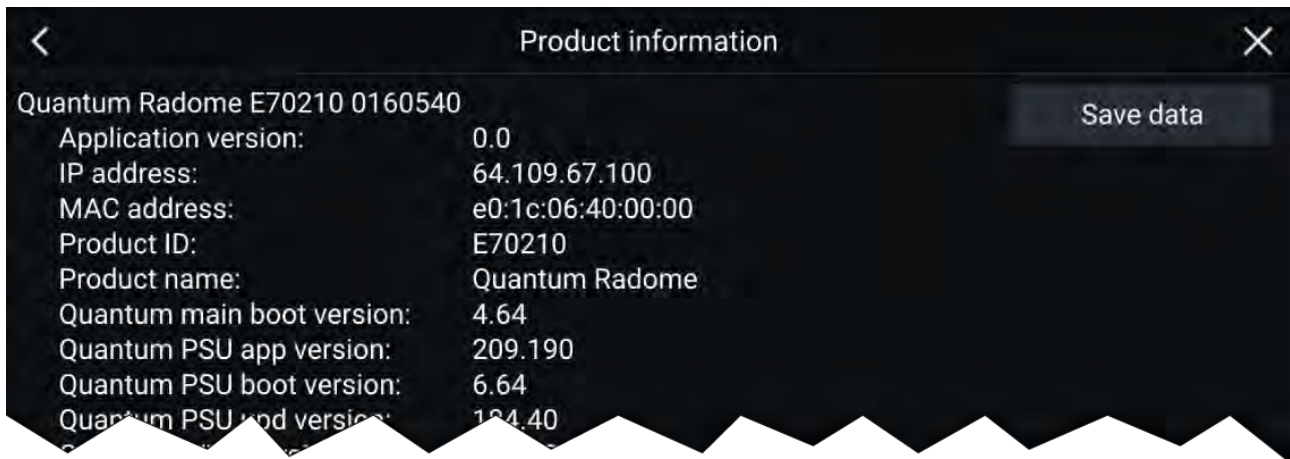

Saving product information

Diagnostic product information can be saved to MicroSD card for off boat records.

With the Diagnostics product information page displayed:

1. Select **Save data**.
2. Select the storage device you want to save the data to.
3. Enter a filename.
4. Select **Save**.
5. Select **OK**.

A .json file will be saved, using your chosen filename to your memory card.

You may view the file using a most standard notepad applications.

23.3 Power up troubleshooting

Product does not turn on or keeps turning off

Possible causes	Possible solutions
Blown fuse / tripped breaker.	<ol style="list-style-type: none"> 1. Check condition of relevant fuses and breakers and connections, replace if necessary. (Refer to the <i>Technical Specification</i> section of your product's installation instructions for fuse ratings.) 2. If fuse keeps blowing check for cable damage, broken connector pins or incorrect wiring.
Poor / damaged / insecure power supply cable / connections	<ol style="list-style-type: none"> 1. Check that the power cable connector is correctly orientated and fully inserted into the display connector and locked in position. 2. Check the power supply cable and connectors for signs of damage or corrosion, and replace if necessary. 3. With the display turned on, try flexing the power cable near to the display connector to see if this causes the unit to restart or lose power. Replace if necessary. 4. Check the vessel's battery voltage and the condition of the battery terminals and power supply cables, ensuring connections are secure, clean and free from corrosion. Replace if necessary. 5. With the product under load, using a multi-meter, check for high voltage drop across all connectors / fuses etc, and replace if necessary.
Incorrect power connection	The power supply may be wired incorrectly, ensure the installation instructions have been followed.

Product will not start up (restart loop)

Possible causes	Possible solutions
Power supply and connection	See possible solutions from the table above, entitled 'Product does not turn on or keeps turning off'.
Software corruption	<ol style="list-style-type: none"> 1. In the unlikely event that the product's software has become corrupted, try downloading and installing the latest software from the Raymarine website. 2. On display products, as a last resort, attempt to perform a 'Power on Reset'. Be aware that this will delete all settings / presets and user data (such as waypoints and tracks), and revert the unit back to factory defaults.



Warning: Factory reset warning

Performing a factory reset will restore all system and app settings to factory defaults and erase all user data (such as waypoints, routes, tracks, camera recordings and photos).

Performing a power on reset — Axiom™

Important:

- Before performing a power on reset ensure you have backed up your settings and user data (waypoints, routes and tracks) to a memory card.
- You may also want to save any crash logs that are stored on your MFD to memory card for future reference..

1. Switch off power at the breaker to ensure that the MFD is completely powered off, and not in Standby mode. Alternatively, remove the power cable from the display.

2. Power on your MFD, and within approximately 10 seconds, swipe your finger from right to left (opposite direction to powering on) across the **Power** button swipe area 5 times.
Recovery options are displayed.
3. Swipe your finger from right to left twice to highlight **Wipe data/factory reset**.
4. Swipe your finger from left to right once to accept.
5. Swipe your finger from right to left once to highlight **Yes**.
6. Swipe your finger from left to right once to restore your MFD to factory default settings.
7. When **Data wipe complete** is displayed, swipe your finger from left to right to restart your MFD.

Performing a power on reset - Axiom Pro

Important:

Before performing a power on reset ensure you have backed up your settings and user data to a memory card.

1. Switch off power at the breaker to ensure that the MFD is completely powered off, and not in Standby mode. Alternatively, remove the power cable from the display.
2. Within approximately 10 seconds of powering on your MFD, press and hold the **Back** and **Switch active** buttons until the screen goes black and the Raymarine logo appears.
The MFD will boot into Recovery mode.
3. Use the directional controls to highlight **Wipe data/factory reset**.
4. Press **Ok**.
5. Select **Yes** to restore your MFD to factory default settings.
6. When 'Data wipe complete' is displayed, select **Reboot system** now.

Performing a Power on Reset - eS and gS Series MFDs

1. Power the MFD off.
2. Power the MFD back on.
3. When the Raymarine logo appears press and hold the **Power** button, until the Initialization screen is displayed.
4. Press the Waypoint button to restore your MFD to factory default settings.

The MFD will reboot when complete.

23.4 Radar troubleshooting

No connection can be made to the scanner

Possible Causes	Possible Solution
Radar powered down	<ul style="list-style-type: none"> If the scanner product has shut down, power it up by opening the Radar app and selecting the Power icon. A Quantum Radar will shut down after 30 minutes if neither a wired (RayNet) , nor a wireless (Wi-Fi) connection can be made to a MFD.
Radar not transmitting	<ul style="list-style-type: none"> Select Transmit for the relevant Radar scanner from the Radar app.
Missing or incorrect Wi-Fi credentials	<ul style="list-style-type: none"> If using a wireless (Wi-Fi) connection, check that you have entered the correct SSID and passcode for your Radar. Both the SSID and passcode are provided on the Radar scanner's packaging, and are also shown on the serial number label on the underside of the product.
Damaged or disconnected Power cable / RayNet cable	<ol style="list-style-type: none"> Check that the cable connectors are fully inserted and locked in position. Check the power supply cable and connectors for signs of damage or corrosion, replace if necessary. With the product turned on, try flexing the cable near to the display connector to see if this causes the product to re-boot/lose power, replace if necessary. Check the vessel's battery voltage, the condition of the battery terminals and power supply cables, ensuring connections are secure, clean and free from corrosion, replace if necessary. With the product under load, using a multi-meter, check for high voltage drop across all connectors/fuses etc (this can cause the product to reset/turn off), replace if necessary. Check condition of relevant breakers and fuses, replace if necessary. If the breaker keeps tripping or fuses keep blowing, contact a Raymarine authorized dealer for assistance.
Open Array power in Off position	<ul style="list-style-type: none"> Ensure Open Array power switch is in the On position.
Software mismatch between equipment may prevent communication	<ul style="list-style-type: none"> Ensure all Raymarine products contain the latest available software, check the Raymarine website: www.raymarine.com/software for software compatibility.

Poor image quality

Possible Causes	Possible Solution
High network bandwidth usage may interfere with a Quantum Radar connected wirelessly	<ul style="list-style-type: none"> Disconnect Wireless display and close the Wireless display page. Disconnect other devices connected wirelessly.

Displayed bearing is different to the true bearing

Possible Causes	Possible Solution
Bearing alignment adjustment required	<ul style="list-style-type: none"> Carry out the Bearing Alignment procedure.

Radar will not initialize (Voltage control module (VCM) stuck in "sleep mode")

Possible Causes	Possible Solution
Intermittent or poor power connection	Check power connection at VCM. (Voltage at input = 12 / 24 V, Voltage at output = 40 V)

23.5 GNSS (GPS) troubleshooting

No fix displayed

Possible causes	Possible solutions
Geographic location or prevailing conditions preventing satellite fix.	Check to see if a fix is obtained in better conditions or another geographic location.
GNSS (GPS) connection fault.	Ensure that external GNSS (GPS) connections and cabling are correct and fault free.
External GNSS (GPS) receiver in poor location e.g.: <ul style="list-style-type: none"> Below decks. Close proximity to transmitting equipment, such as a VHF radio. 	Ensure GNSS (GPS) receiver has a clear view of the sky.
GNSS (GPS) installation problem.	Refer to the installation instructions supplied with your product.

Note: A GNSS (GPS) Status screen is accessible from the display. This provides satellite signal strength and other relevant information.

23.6 Sonar troubleshooting

Scrolling image is not being displayed

Possible causes	Possible solutions
Sonar disabled	Enable Ping from the Fishfinder app's sounder tab: Menu > Settings > Sounder > Ping .
Incorrect transducer selected	Check that the correct transducer is selected in the Fishfinder app's Transducer tab: Menu > Settings > Transducer > Ping .
Damaged cables	<ol style="list-style-type: none"> Check that the transducer cable connector is fully inserted and locked in position. Check the power supply cable and connectors for signs of damage or corrosion, replace if necessary. With the unit turned on, try flexing the cable near to the display connector to see if this causes the unit to re-boot/loose power, replace if necessary. Check the vessel's battery voltage, the condition of the battery terminals and power supply cables, ensuring connections are secure, clean and free from corrosion, replace if necessary. With the product under load, using a multi-meter, check for high voltage drop across all connectors/fuses etc (this can cause the Fishfinder applications to stop scrolling or the unit to reset/turn off), replace if necessary.
Damaged or fouled transducer	Check transducer condition, ensuring it is not damaged and is free from debris/fouling. If necessary, clean or replace your transducer. After cleaning or replacement coat the transducer using a water-based anti-fouling paint.
Wrong transducer fitted	Check product and transducer documentation and ensure that the transducer is compatible with your system.
External sonar module: SeaTalkhs / RayNet network problem.	<ul style="list-style-type: none"> Check that the unit is correctly connected to the Display or network switch. Check all connections ensuring connections are secure, clean and free from corrosion, replace if necessary.
External sonar module: Software mismatch between equipment may prevent communication.	Ensure all Raymarine products contain the latest available software, check the Raymarine website: www.raymarine.com/software for software compatibility.

No depth reading / lost bottom lock

Possible causes	Possible solutions
Transducer location	Check that the transducer has been installed in accordance with the instructions provided with the transducer.
Transducer angle	If the transducer angle is too great the beam can miss the bottom, adjust transducer angle and recheck.
Transducer kicked-up	If the transducer has a kick-up mechanism, check that it has not kicked up due to hitting an object.
Power source insufficient	With the product under load, using a multi-meter, check the power supply voltage as close to the unit as possible to establish actual voltage when the current is flowing. (Check your product's Technical specification for power supply requirements.)
Damaged or fouled transducer	Check transducer condition, ensuring it is not damaged and is free from debris/fouling. If necessary, clean or replace your transducer. After cleaning or replacement coat the transducer using a water-based anti-fouling paint.
Damaged cables	<ol style="list-style-type: none"> 1. Check the unit's connector for broken or bent pins. 2. Check that the cable connector is fully inserted into the unit and that the locking collar is in the locked position. 3. Check the cable and connectors for signs of damage or corrosion, replace if necessary. 4. With the unit turned on, try flexing the power cable near to the display connector to see if this causes the unit to re-boot/lose power, replace if necessary. 5. Check the vessel's battery voltage, the condition of the battery terminals and power supply cables, ensuring connections are secure, clean and free from corrosion, replace if necessary. 6. With the product under load, using a multi-meter, check for high voltage drop across all connectors/fuses etc (this can cause the Fishfinder applications to stop scrolling or the unit to reset/turn off), replace if necessary.
Vessel speed too high	Slow vessel speed and recheck.
Bottom too shallow or too deep	The bottom depth may be outside of the transducers depth range, move vessel to shallower or deeper waters as relevant and recheck.
Ping depth limit set	<p>If using a transducer with greater than 600 W power, check if the Ping depth limit has been enabled: Menu > Settings > Transducer > Ping depth limit.</p> <p>If you are in water deeper than the specified Ping depth limit then the transducer may not provide depth readings.</p> <p>Disable or adjust setting and retry.</p>

Poor / problematic image

Possible causes	Possible solutions
Targets will appear differently if your vessel is stationary (e.g.: fish will appear on the display as straight lines).	Increase vessel speed.
Scrolling paused or speed set too low	Unpause or increase sonar scrolling speed.
Sensitivity settings may be inappropriate for present conditions.	Check and adjust sensitivity settings or perform a Sonar reset.

Possible causes	Possible solutions
Damaged cables	<ol style="list-style-type: none"> 1. Check the unit's connector for broken or bent pins. 2. Check that the cable connector is fully inserted into the unit and that the locking collar is in the locked position. 3. Check the cable and connectors for signs of damage or corrosion, replace if necessary. 4. With the unit turned on, try flexing the power cable near to the display connector to see if this causes the unit to re-boot/loose power, replace if necessary. 5. Check the vessel's battery voltage, the condition of the battery terminals and power supply cables, ensuring connections are secure, clean and free from corrosion, replace if necessary. 6. With the product under load, using a multi-meter, check for high voltage drop across all connectors/fuses etc (this can cause the Fishfinder applications to stop scrolling or the unit to reset/turn off), replace if necessary.
Transducer location	<ul style="list-style-type: none"> • Check that the transducer has been installed in accordance with the instructions provided with the transducer. • If a transom mount transducer is mounted too high on the transom it may be lifting out of the water, check that the transducer face is fully submerged when planing and turning.
Transducer kicked-up	If the transducer has a kick-up mechanism, check that it has not kicked up due to hitting an object.
Damaged or fouled transducer	Check transducer condition, ensuring it is not damaged and is free from debris/fouling. If necessary, clean or replace your transducer. After cleaning or replacement coat the transducer using a water-based anti-fouling paint.
Damaged transducer cable	Check that the transducer cable and connection is free from damage and that the connections are secure and free from corrosion.
Turbulence around the transducer at higher speeds may affect transducer performance	Slow vessel speed and recheck.
Interference from another transducer	<ol style="list-style-type: none"> 1. Turn off the transducer causing the interference. 2. Reposition the transducers so they are farther apart.
Unit power supply fault	Check the voltage from the power supply, if this is too low it can affect the transmitting power of the unit.

23.7 Camera troubleshooting

Video not displayed

Possible causes	Possible solutions
Incorrect power up sequence	Your MFD needs to be powered up before your camera to enable the MFD to provide the camera with a valid IP address.
Camera not compatible.	Ensure the camera feed and network settings are compatible: <ul style="list-style-type: none"> • Camera feed should be set to 720p max. • Network should be set to obtain network address automatically (DHCP).

Possible causes	Possible solutions
	<ul style="list-style-type: none"> Anonymous login should be enabled.
Too many IP feeds on network.	Displaying multiple feeds on multiple MFDs simultaneously may cause some feeds to not be displayed. Try viewing less feeds.
Problem with the camera connections.	<ol style="list-style-type: none"> Check the unit's connector for broken or bent pins. Check that the cable connector is fully inserted into the unit and that the locking collar is in the locked position. Check the cable and connectors for signs of damage or corrosion, replace if necessary. With the unit turned on, try flexing the power cable to see if this causes the unit to re-boot/loose power, replace if necessary.
Problem with power supply to the camera or thermal camera's JCU (if used as the primary controller)	<ul style="list-style-type: none"> Check the power connections to the camera, JCU, and PoE injector (if used). Ensure that the power switch / breaker is on. Check the fuse / breaker state.
Camera is in Standby mode.	Use the camera controls (either the Camera app or a Thermal camera's JCU) to "wake" the camera from standby.

PTZ cameras — Erratic or unresponsive controls

Possible causes	Possible solutions
Network problem.	<ul style="list-style-type: none"> Check that the controller and camera are correctly connected to the network. If used, check the status of the network switch. Check that RayNet cables are free from damage.
Control conflict, e.g. caused by multiple users at different stations.	Ensure that no other controllers are in use at the same time.
Problem with the controller.	<ul style="list-style-type: none"> Check power / network cabling to the controller and PoE injector, if used. Check other controllers, if available.

Cannot switch between camera feeds

Possible causes	Possible solutions
Camera is not a dual payload model.	Only "dual payload" (dual lens) cameras support feed switching.

Noisy image

Possible causes	Possible solutions
Poor quality or faulty cabling.	<ul style="list-style-type: none"> Ensure cable runs are no longer than they need to be. Use only high quality shielded cable suitable for the marine environment.
Cable is picking up electromagnetic interference (EMI) from another device.	<ul style="list-style-type: none"> Ensure you are using a high quality shielded cable. Ensure proper cable separation, for example do not run data and power cables in close proximity with each other. In certain conditions it may be necessary to fit suppression ferrites to cabling to eliminate interference.

Image too dark or too light

Possible causes	Possible solutions
Brightness set too low.	Check MFD brightness and adjust if necessary.
The contrast and / or brightness settings in the Camera app are set too low.	Check Camera brightness and contrast, adjust if necessary.
The Scene Mode is not appropriate for the current conditions.	When viewing a thermal camera feed, a particular environment may benefit from using a different Scene Mode setting. For example, a very cold background (such as the sky) could cause the camera to use a wider temperature range than appropriate. Adjust the Scene as appropriate.

Image freezes momentarily

Possible causes	Possible solutions
FFC (Flat Field Correction).	A Thermal camera's image will pause momentarily on a periodic basis during the Flat Field Correction (FFC) cycle. Just prior to the FFC, a small green square may appear in the upper left corner of the screen.

Image is inverted (upside down or mirror image)

Possible causes	Possible solutions
Vertical or Horizontal flip control incorrectly set	Check the image flip controls to ensure they are set correctly for your installation.

23.8 Augmented Reality (AR) Troubleshooting

AR options not available in Video app

Possible causes	Possible solutions
Wrong camera selected.	Ensure that the correct AR-compatible camera has been selected in the Video app menu.
Compatible camera not detected.	<ol style="list-style-type: none"> 1. Ensure your camera is AR compatible. 2. Ensure your camera is correctly installed and networked to your MFD.
AR200 not detected.	<ol style="list-style-type: none"> 1. Ensure your AR200 is correctly installed and on the same network as the MFD from which you are using the AR features.
Incorrect LightHouse™ 3 software version.	Ensure that your MFD is running LightHouse™ 3 version 3.7 or above.
AR options turned off.	<p>The Compass bar, AIS, Waypoint and Chart object flags can be enabled and disabled from the ClearCruise settings page (Video app > Menu > Settings > ClearCruise). Ensure relevant options are enabled.</p> <hr/> <p>Note:</p> <p>For AIS flags to be displayed, compatible AIS hardware must be operational and connected to the same network as your MFD.</p>

AR flags do not appear directly above on-screen target

Possible causes	Possible solutions
AIS update rate	Depending on the classification of the target's AIS hardware, transmitted position updates may be sent up to 3 minutes apart and therefore the flag may appear up to 3 minutes behind the actual onscreen target.
Camera Field of View (FOV) set incorrectly.	Ensure that the FOV setting reflects your camera's horizontal FOV. Check your camera's documentation for FOV specifications.
AR200 interference	If your AR200 is installed in a location which includes a source of magnetic interference large enough to affect AR flag placement, you may need to re-install the AR200 in a different location.
Deviation too high	<ol style="list-style-type: none"> 1. Reset the AR200 calibration by selecting Reset from the AR200 calibration page: Homescreen > Settings > Network > Data sources > Heading > Raymarine AR200 Attitude > Calibrate. 2. If the problem persists, you may need to move your AR200 to a location with less magnetic interference.

23.9 Wi-Fi troubleshooting

Before troubleshooting problems with your Wi-Fi connection, ensure that you have followed the Wi-Fi location requirements guidance provided in the relevant installation instructions and performed a power cycle/reboot of the devices you are experiencing problems with.

Cannot find network

Possible cause	Possible solutions
Wi-Fi not currently enabled on devices.	Ensure Wi-Fi is enabled on both Wi-Fi devices and rescan available networks.
Some devices may automatically turn off Wi-Fi when not in use to save power.	Power cycle / reboot devices and rescan available networks.
Device not broadcasting.	<ol style="list-style-type: none"> 1. Try to enable broadcasting of the device's network using the Wi-Fi settings on the device you are trying to connect to. 2. You may still be able to connect to the device, when it is not broadcasting, by manually entering the device's Wi-Fi Name / SSID and passphrase in the connection settings of the device you are trying to connect.
Devices out of range or signal being blocked.	Move devices closer together or, if possible remove the obstructions and then rescan available network.

Cannot connect to network

Possible cause	Possible solutions
Some devices may automatically turn off Wi-Fi when not in use to save power.	Power cycle/reboot devices and retry the connection.
Trying to connect to the wrong Wi-Fi network	Ensure you are trying to connect to the correct Wi-Fi network, the Wi-Fi network's name can be found in the Wi-Fi settings on the broadcasting device (the device that you are trying to connect to).
Incorrect network credentials	Ensure you are using the correct passphrase, the Wi-Fi network's passphrase can be found in the Wi-Fi settings on the broadcasting device (the device that you are trying to connect to).
Bulkheads, decks and other heavy structure can degrade and even block the Wi-Fi signal. Depending on the thickness and material used it may not always be possible to pass a Wi-Fi signal through certain structures	<ol style="list-style-type: none"> 1. Try repositioning the devices so the structure is removed from the direct line of sight between the devices, or 2. If possible use a wired connection instead.
Interference being caused by other Wi-Fi enabled or older Bluetooth enabled devices (Bluetooth and Wi-Fi both operate in the 2.4 GHz frequency range, some older bluetooth devices may interfere with Wi-Fi signals.)	<ol style="list-style-type: none"> 1. Change the Wi-Fi Channel of the device you are trying to connect to and retry the connection. You can use free Wi-Fi analyzer apps on your smart device to help you choose a better channel (channel with least traffic). 2. Temporarily disable each wireless device in turn until you have identified the device causing the interference.

Possible cause	Possible solutions
<p>Interference caused by other devices that use the 2.4GHz frequency See list below of some common devices that use the 2.4GHz frequency:</p> <ul style="list-style-type: none"> • Microwave ovens • Fluorescent lighting • Cordless phones / baby monitors • Motion sensors 	<p>Temporarily switch off each device in turn until you have identified the device causing the interference, then remove or reposition the offending device(s).</p>
<p>Interference caused by electrical and electronic devices and associated cabling could generate an electromagnetic field which may interfere with the Wi-Fi signal.</p>	<p>Temporarily switch off each item in turn until you have identified the device causing the interference, then remove or reposition the offending device(s).</p>

Connection extremely slow and or keeps dropping out

Possible cause	Possible solutions
<p>Wi-Fi performance degrades over distance so products farther away will receive less network bandwidth. Products installed close to their maximum Wi-Fi range will experience slow connection speeds, signal drop outs or not being able to connect at all.</p>	<ul style="list-style-type: none"> • Move devices closer together. • For fixed installations such as a Quantum Radar, enable the Wi-Fi connection on an MFD installed closer to the device.
<p>Interference being caused by other Wi-Fi enabled or older Bluetooth enabled devices (Bluetooth and Wi-Fi both operate in the 2.4 GHz frequency range, some older bluetooth devices may interfere with Wi-Fi signals.)</p>	<ol style="list-style-type: none"> 1. Change the Wi-Fi Channel of the device you are trying to connect to and retry the connection. You can use free Wi-Fi analyzer apps on your smart device to help you choose a better channel (channel with least traffic). 2. Temporarily switch off each device in turn until you have identified the device causing the interference, then remove or reposition the offending device(s).
<p>Interference from devices on other vessels. When in close proximity to other vessels, for example, when moored up in a marina, many other Wi-Fi signals may be present.</p>	<ol style="list-style-type: none"> 1. Change the Wi-Fi Channel of the device you are trying to connect to and retry the connection. You can use free Wi-Fi analyzer apps on your smart device to help you choose a better channel (channel with least traffic). 2. If possible, move your vessel to a location with less Wi-Fi traffic.

Network connection established but no data

Possible cause	Possible solutions
<p>Connected to the wrong network.</p>	<p>Ensure that your devices is connected to the correct network.</p>
<p>Device software incompatibility</p>	<p>Ensure both devices are running the latest available software.</p>
<p>It may be possible that the device has become defective</p>	<ol style="list-style-type: none"> 1. Try updating software to a later version, or 2. try reinstalling the software. 3. Obtain new replacement device.

Mobile application running slowly or not at all

Possible cause	Possible solutions
Raymarine app not installed	Install mobile app from relevant app store.
Raymarine app version not compatible with MFD software	Ensure mobile app and MFD software are latest available versions.
Mobile apps not enabled on MFD	Enable “Viewing only” or “Remote Control” as required in the Mobile Apps setting on your MFD.

23.10 Wireless display troubleshooting

Cannot connect to wireless display

Possible cause	Possible solutions
Some Miracast compatible but non certified devices may not be able to connect with Wi-Fi Sharing enabled.	Disable Wi-Fi Sharing on your MFD and retry connection.
Wi-Fi Sharing has been enabled or disabled since the wireless display was first connected.	Try power cycling devices and trying again. Depending on dongle used a factory reset may be required to establish a connection.
Missed confirmation on wireless display	Restart connection procedure and ensure you check the wireless display for confirmation dialogs.
Wireless display too far away	Try moving the wireless display closer to the MFD and retry connection.
Chromecast devices are not supported.	Purchase a Miracast compatible device.

Poor performance

Possible cause	Possible solutions
High video processing demand.	The Camera app, Raymarine mobile app connections can interfere with the wireless display performance as they use shared video processing resource. Try switching off video feeds and/or mobile app connections.
Wireless display too far away	Try moving the wireless display closer to the MFD and retry connection.

Wireless display disconnects

Possible cause	Possible solutions
Changing the Wi-Fi Sharing option on your MFD will cause the wireless display to disconnect.	Do not change Wi-Fi sharing options whilst connected to a wireless display. Wireless display may require factory reset to re-establish connection.
Quantum wireless pairing process will cause wireless display to disconnect.	Do not pair with a Quantum Radar whilst wireless display connection is active.
Wireless display too far away	Try moving the wireless display closer to the MFD and retry connection.

23.11 Data troubleshooting

Instrument, engine or other system data is unavailable at all displays

Possible causes	Possible solutions
Data is not being received at the display(s).	<ul style="list-style-type: none"> • Check transmitted data is compatible with your display. Refer to MFD supported PGN list. • Check the data bus (e.g. SeaTalk^{ng}) wiring and connections.
Data source (e.g. instrument display or engine interface) is not operating.	<ul style="list-style-type: none"> • Check the source of the missing data (e.g. instrument display or engine interface). • Check power to the data bus.
Software mismatch between equipment may prevent communication.	<ul style="list-style-type: none"> • Check the Raymarine website and ensure all your Raymarine products have the latest software.

Instrument or other system data is missing from some but not all displays

Possible causes	Possible solutions
Network connection problem.	<ul style="list-style-type: none"> • Check that all required equipment is connected to the same network. • Check correct operation of network switch, if used. • Check network cabling is correct and free from damage.
Software mismatch between equipment may prevent communication.	Check all MFDs are using the same version of software.

23.12 Touchscreen troubleshooting

Touchscreen does not operate as expected.

Possible causes	Possible solutions
Touch lock is enabled.	Disable TouchLock, using the power button..
Screen is not being operated with bare fingers, for example gloves are being worn.	Bare fingers must make contact with the screen for correct operation. Alternatively you may use conductive gloves.
Saltwater deposits on the screen.	Carefully clean and dry the screen with a damp non-abrasive cloth.

Chapter 24: Technical support

Chapter contents

- [24.1 Raymarine product support and servicing on page 422](#)
- [24.2 Learning resources on page 424](#)

24.1 Raymarine product support and servicing

Raymarine provides a comprehensive product support service, as well as warranty, service, and repairs. You can access these services through the Raymarine website, telephone, and e-mail.

Product information

If you need to request service or support, please have the following information to hand:

- Product name.
- Product identity.
- Serial number.
- Software application version.
- System diagrams.

You can obtain this product information using diagnostic pages of the connected MFD.

Servicing and warranty

Raymarine offers dedicated service departments for warranty, service, and repairs.

Don't forget to visit the Raymarine website to register your product for extended warranty benefits:

<http://www.raymarine.co.uk/display/?id=788>.

United Kingdom (UK), EMEA, and Asia Pacific:

- E-Mail: emea.service@raymarine.com
- Tel: +44 (0)1329 246 932

United States (US):

- E-Mail: rm-usrepair@flir.com
- Tel: +1 (603) 324 7900

Web support

Please visit the "Support" area of the Raymarine website for:

- **Manuals and Documents** — <http://www.raymarine.com/manuals>
- **Technical support forum** — <http://forum.raymarine.com>
- **Software updates** — <http://www.raymarine.com/software>

Worldwide support

United Kingdom (UK), EMEA, and Asia Pacific:

- Help desk: <https://raymarine.custhelp.com/app/ask>
- Tel: +44 (0)1329 246 777

United States (US):

- Help desk: <https://raymarine.custhelp.com/app/ask>
- Tel: +1 (603) 324 7900 (Toll-free: +800 539 5539)

Australia and New Zealand (Raymarine subsidiary):

- E-Mail: aus.support@raymarine.com
- Tel: +61 2 8977 0300

France (Raymarine subsidiary):

- E-Mail: support.fr@raymarine.com
- Tel: +33 (0)1 46 49 72 30

Germany (Raymarine subsidiary):

- E-Mail: support.de@raymarine.com
- Tel: +49 40 237 808 0

Italy (Raymarine subsidiary):

- E-Mail: support.it@raymarine.com
- Tel: +39 02 9945 1001

Spain (Authorized Raymarine distributor):

- E-Mail: sat@azimut.es

- Tel: +34 96 2965 102

Netherlands (Raymarine subsidiary):

- E-Mail: support.nl@raymarine.com
- Tel: +31 (0)26 3614 905

Sweden (Raymarine subsidiary):

- E-Mail: support.se@raymarine.com
- Tel: +46 (0)317 633 670

Finland (Raymarine subsidiary):

- E-Mail: support.fi@raymarine.com
- Tel: +358 (0)207 619 937

Norway (Raymarine subsidiary):

- E-Mail: support.no@raymarine.com
- Tel: +47 692 64 600

Denmark (Raymarine subsidiary):

- E-Mail: support.dk@raymarine.com
- Tel: +45 437 164 64

Russia (Authorized Raymarine distributor):

- E-Mail: info@mikstmarine.ru
- Tel: +7 495 788 0508

Viewing product information (LightHouse™ 3)

Use the **Settings** menu to view hardware and software information about your MFD, and connected products.

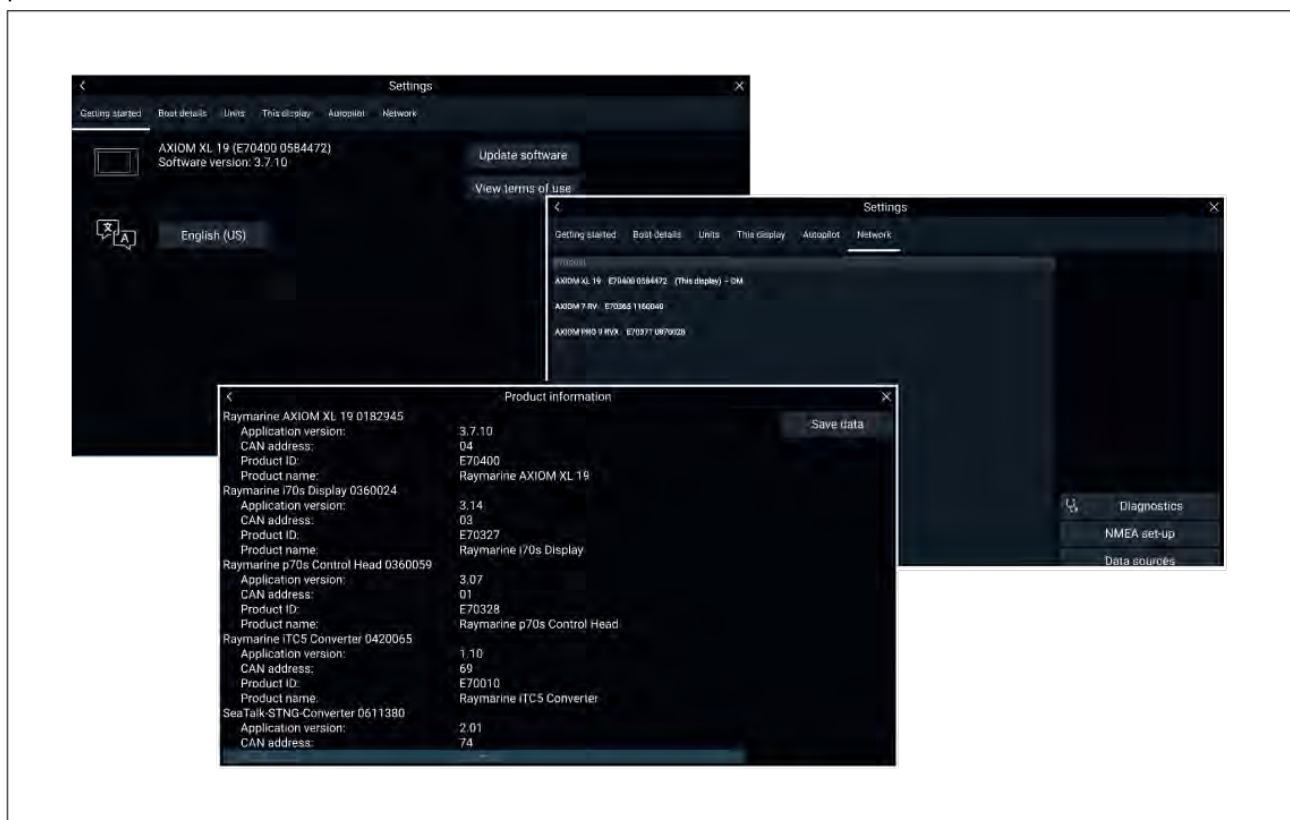

1. Select **Settings**, from the Homescreen.

The **Getting started** menu contains hardware and software information for your MFD.

2. You can view further information about your MFD, or view information about products networked using SeaTalkhs® and SeaTalkng® / NMEA 2000, by selecting the **Network** tab, then:
 - i. to display detailed software information and your MFD's network IP address, select your MFD from the list.

- ii. to display detailed diagnostics information for all products, select **Product info** from the **Diagnostics** pop over menu.

Remote Support via AnyDesk

LightHouse 3 software versions v3.13 or later support remote support functions via the preloaded AnyDesk app.

The AnyDesk app enables a Raymarine Product Support representative to remotely connect to and control your MFD over an Internet connection, for the purposes of technical support and troubleshooting.

To get started, you will first need to contact Raymarine Product Support. If the representative considers that your support case would benefit from a remote session, you need to first ensure that your MFD has an active Internet connection via Wi-Fi. Next, launch the AnyDesk app from your MFD's homescreen, and then provide the displayed unique ID to the Raymarine Product Support representative. Then follow any further instructions provided to you by the representative.

Attention

- **AnyDesk is provided for troubleshooting and support purposes only, and is NOT intended to perform remote functions on your vessel. Raymarine will NOT be held liable for damage or injury to equipment or persons caused by the use of a remote connection to your MFD.**
- **Do not disclose your AnyDesk ID to anyone other than authorised Raymarine Product Support personnel.**
- **Do not use the AnyDesk app to remotely activate connected devices such as Autopilot, Radar or Sonar hardware.**

24.2 Learning resources

Raymarine has produced a range of learning resources to help you get the most out of your products.

Video tutorials

Raymarine official channel on YouTube:

- [YouTube](#)

LightHouse™ 3 tips and tricks:

- [Raymarine website](#)

Video Gallery:

- [Raymarine website](#)

Note:

- Viewing the videos requires a device with an Internet connection.
- Some videos are only available in English.

Training courses

Raymarine regularly runs a range of in-depth training courses to help you make the most of your products. Visit the Training section of the Raymarine website for more information:

- <http://www.raymarine.co.uk/view/?id=2372>

Technical support forum

You can use the Technical support forum to ask a technical question about a Raymarine product or to find out how other customers are using their Raymarine equipment. The resource is regularly updated with contributions from Raymarine customers and staff:

- <http://forum.raymarine.com>

Appendix A NMEA 0183 sentence support

Note:

NMEA 0183 sentence support is dependent on MFD variant.

- Axiom® and Axiom®+ MFDs do NOT support NMEA 0183 connections.
- Axiom® Pro and Axiom® XL MFDs support NMEA 0183 connections.

Supported sentences:

- **AAM** — Waypoint Arrival Alarm (Receive / Transmit)
- **APB** — Autopilot B Sentence (Receive / Transmit)
- **BWC** — Bearing & Distance to Waypoint — Great Circle (Receive / Transmit)
- **BWR** — Bearing & Distance to Waypoint — Rhumb Line (Receive / Transmit)
- **DBT** — Depth Below Transducer (Receive / Transmit)
- **DPT** — Depth (Receive / Transmit)
- **DSC** — Digital Selective Calling Information (Receive)
- **DSE** — Extended DSC (Receive)
- **DTM** — Datum Reference (Receive / Transmit)
- **GBS** — GPS Satellite Fault Detection (Receive / Transmit)
- **GGA** — Global Positioning System Fix Data (Receive / Transmit)
- **GLL** — Geographic Position — Latitude / Longitude (Receive / Transmit)
- **GLC** — Geographic Position — Loran-C (Receive / Transmit)
- **GSA** — GPS DOP & Active Satellites (Receive / Transmit)
- **GST** — GPS Pseudorange Error Statistic (Receive / Transmit)
- **GSV** — GPS Satellites in View (Receive / Transmit)
- **HDG** — Heading — Deviation & Variation (Receive / Transmit)
- **HDM** — Heading — Magnetic (Receive / Transmit)
- **HDT** — Heading — True (Receive / Transmit)
- **MDA** — Meteorological Composite (Receive / Transmit)
- **MSK** — Control for a Beacon Receiver (Receive / Transmit)
- **MSS** — Beacon Receiver Status (Receive / Transmit)
- **MTW** — Mean Temperature of Water (Receive / Transmit)
- **MWV** — Wind Speed and Angle (Receive / Transmit)
- **RMA** — Recommended Minimum Navigation Information — Loran-C Data (Receive / Transmit)
- **RMB** — Recommended Minimum Navigation Information — GPS Data (Receive / Transmit)
- **RMC** — Recommended Minimum Navigation Information — Specific GPS Data (Receive / Transmit)
- **RTE** — Routes (Receive / Transmit)
- **VHW** — Water Speed and Heading (Receive / Transmit)
- **VLW** — Distance Travelled Through Water (Receive / Transmit)
- **VTG** — Course Over ground & Ground Speed (Receive / Transmit)
- **WPL** — Waypoint Location (Receive / Transmit)
- **XTE** — Measured Cross Track Error (Receive / Transmit)
- **ZDA** — Time & date (Receive / Transmit)

Appendix B NMEA 2000 PGN support

Administration PGNs

- **59392** — ISO Acknowledge (Receive / Transmit)
- **59904** — ISO Request (Receive / Transmit)
- **60160** — ISO Transport Protocol, Data Transfer (Receive)
- **60416** — ISO Transport Protocol, Connection Management — BAM Group Function (Receive)
- **60928** — ISO Address Claim (Receive / Transmit)
- **65240** — ISO Commanded address (Receive)
- **126208** — NMEA — Request, Commanded, Acknowledged Group Function (Receive / Transmit)
- **126464** — PGN Transmit and Receive List (Transmit)
- **126996** — Product Information (Receive / Transmit)
- **126998** — Configuration Information (Receive / Transmit)

Data PGNs

- **126983** — Alert (Receive)
- **126984** — Alert Response (Transmit)
- **126985** — Alert Text (Receive)
- **126986** — Alert Configuration (Receive)
- **126992** — System Time (Receive / Transmit)
- **126993** — Heartbeat (Receive / Transmit)
- **127237** — Heading/Track Control (Receive)
- **127245** — Rudder (Receive)
- **127250** — Vessel Heading (Receive / Transmit)
- **127251** — Rate of Turn (Receive / Transmit)
- **127257** — Attitude (Receive / Transmit)
- **127258** — Magnetic Variation (Transmit)
- **127488** — Engine Parameters, Rapid Update (Receive)
- **127489** — Engine Parameters, Dynamic (Receive)
- **127493** — Transmission Parameters, Dynamic (Receive)
- **127496** — Trip Parameters, Vessel (Receive)
- **127497** — Trip Parameters, Engine (Receive)
- **127498** — Engine Parameters, Static (Receive)
- **127503** — AC input status (Receive)
- **127504** — AC output status (Receive)
- **127505** — Fluid Level (Receive)
- **127506** — DC detailed status (Receive)
- **127507** — Charger status (Receive)
- **127508** — Battery status (Receive)
- **127509** — Inverter status (Receive)
- **128259** — Speed, (Receive / Transmit)
- **128267** — Water Depth (Receive / Transmit)
- **128275** — Distance Log (Receive / Transmit)
- **129025** — Position, Rapid Update (Receive / Transmit)
- **129026** — COG & SOG, Rapid Update (Receive / Transmit)
- **129029** — GNSS Position Data (Receive / Transmit)
- **129033** — Time & Date (Receive / Transmit)
- **129038** — AIS Class A Position Report (Receive)
- **129039** — AIS Class B Position Report (Receive)
- **129040** — AIS Class B Extended Position Report (Receive)

- **129041** — AIS Aids to Navigation (AtoN) Report (Receive)
- **129044** — Datum (Receive / Transmit)
- **129283** — Cross Track Error (Receive / Transmit)
- **129284** — Navigation Data (Receive / Transmit)
- **129285** — Navigation — Route / WP Information (Transmit)
- **129291** — Set & Drift, Rapid Update (Receive / Transmit)
- **129301** — Time to/from Mark (Receive)
- **129539** — GNSS DOPs (Receive / Transmit)
- **129540** — GNSS Sats in View (Receive / Transmit)
- **129542** — GNSS Pseudorange Noise Statistics (Receive)
- **129545** — GNSS RAIM Output (Receive)
- **129547** — GNSS Pseudorange Error Statistics (Receive)
- **129550** — GNSS Differential Correction Receiver Interface (Receive)
- **129551** — GNSS Differential Correction Receiver Signal (Receive)
- **129793** — AIS UTC and Date Report (Receive)
- **129794** — AIS Class A Static and Voyage Related Data (Receive)
- **129798** — AIS SAR Aircraft Position Report (Receive)
- **129801** — AIS Addressed Safety Related Message (Receive)
- **129802** — AIS Safety Related Broadcast Message (Receive)
- **129808** — DSC call information (Receive)
- **129809** — AIS Class B "CS" Static Report, Part A (Receive)
- **129810** — AIS Class B "CS" Static Report, Part B (Receive)
- **129811** — AIS Single Slot Binary Message (Receive / Transmit)
- **129812** — AIS Multi Slot Binary Message (Receive / Transmit)
- **130064** — Route and WP Service — Database List (Receive / Transmit)
- **130065** — Route and WP Service — Route List (Receive / Transmit)
- **130066** — Route and WP Service — Route/WP List Attributes (Receive / Transmit)
- **130067** — Route and WP Service — Route/WP Name & Position (Receive / Transmit)
- **130068** — Route and WP Service — Route/WP Name (Receive / Transmit)
- **130069** — Route and WP Service — XTE Limit & Navigation Method (Receive / Transmit)
- **130070** — Route and WP Service — WP Comment (Receive / Transmit)
- **130072** — Route and WP Service — Database Comment (Receive / Transmit)
- **130074** — Route and WP Service — WP List — WP Name & Position (Receive / Transmit)
- **130306** — Wind Data (Receive / Transmit)
- **130310** — Environmental Parameters (Receive / Transmit)
- **130311** — Environmental Parameters (Receive)
- **130312** — Temperature (Receive)
- **130313** — Humidity (Receive)
- **130314** — Actual pressure (Receive)
- **130316** — Temperature, Extended Range (Receive)
- **130569** — Entertainment — Current File and Status (Receive)
- **130570** — Entertainment — Library Data File (Receive)
- **130571** — Entertainment — Library Data Group (Receive)
- **130572** — Entertainment — Library Data Search (Receive)
- **130573** — Entertainment — Supported Source Data (Receive)
- **130574** — Entertainment — Supported Zone Data (Receive)
- **130576** — Small Craft Status (Receive)
- **130577** — Direction Data (Receive / Transmit)
- **130578** — Vessel Speed Components (Receive)

- **130580** — Entertainment — System Configuration Status (Receive)
- **130586** — Entertainment — Zone Configuration Status (Receive)
- **130582** — Entertainment — Zone Volume (Receive)

Raymarine® provides field programmability of the Device and System Instances within PGN 60928 which can be commanded via use of PGN 126208 as required by the latest **NMEA 2000** standard.

Appendix C Document change history

Document revision and (Date)	Software version	Changes
81370-18 (05-2021)	LH3.14.88	<ul style="list-style-type: none"> • Updated software version to 3.14. • Updated New features to reflect V3.14 features. • Added new Mercury VesselView Chapter • Added new chapter for First responder features. • Updated GNSS (GPS) settings to include: signal strength indicator, GNSS constellation selection and SBAS selection details in Homescreen chapter. • Expanded information relating to Multiple data sources (MDS) in the Getting started section of the Setup chapter. • Added details information about DSC integration and DSC waypoints to Homescreen chapter. • Updated Responder menu tab description to refer to new First responder chapter. • Added North America depth soundings statement for LightHouse Charts. • Added Route 'Follow from here' task to Chart chapter. • Updated SAR selection to include Expanding square in Chart app chapter. • Updated Target tracking details in Chart app chapter to include Intel targets and DSC targets for First responders. • Reorganized AIS target information in Chart app chapter. • Reorganized Radar target information in Chart app chapter. • Added details for accessing target options in Chart app chapter. • Updated target vector information in Chart app chapter. • Created new subsection for Collision avoidance in Chart app chapter. • Added new Collision avoidance description in Chart app chapter. • Moved 'Dangerous target alarm' to the Collision avoidance section of the Chart app chapter. • Moved SITREP details to First responder chapter and updated details. • Renamed existing 'collision Avoidance' to 'Predicted areas of danger' in Chart app chapter. • Expanded 'Predicted areas of danger' menu option descriptions in Chart app chapter. • Added details of the new Obstruction alarm for LightHouse charts. • Added details of Danger highlights for LightHouse charts. • Added new chapter for First responder MFD configuration and features. • Added new First responder configuration details to First responder chapter. • Moved Messaging chapter to First responder chapter. • Moved Responder settings menu from Homescreen chapter to First responder chapter. • Added details of STEDs and static data FIDs and FID checksums. • Added details for legacy SITREP FIDs for First responders. • Moved AIS mode details to First responder chapter and updated descriptions. • Moved Blue force AIS icon descriptions from Chart app chapter to First responder chapter.

Document revision and (Date)	Software version	Changes
		<ul style="list-style-type: none"> • Added new Data logging feature to First responder chapter. • Added new SAR pattern receipt details to First responder chapter. • Added details for new Target of interest TOI feature for First responders. • Added details for new DSC target feature for First responders. • Added details for new Intel target feature for First responders. • Corrected supported NMEA 2000 PGN list. • Corrected supported NMEA 0183 sentence list. • Added details of RMK controls to Set up chapter. • Added detailed information regarding depth soundings and contours to chart app. • Added list of pre-loaded LightHouse chart cards to Chart chapter. • Added warnings, vendor compatibility and differences information to Autorouting details. • Added a note to user data export RE LH3 allowing non-unique waypoint names. • Added details of new Ping depth limit feature.
81370–17 (10–2020)	LH3.13.103	<ul style="list-style-type: none"> • Updated new features to reflect LH3.13. • Added waypoints to Radar app overview. • Added show waypoints option to Radar settings menu table.. • Added Chart/Radar sync details to Radar settings table. • Added AIS mode to AIS settings table (first responder). • Added Messages app to MFD app list. • Created a new chapter for Messaging as it is now its own app. • Added details of Inbox export to Messaging app chapter. • Added new multiple interior environment sensors option in boat details. • Added inside environment to available data items in Dashboard app. • Updated chart app to include further details on supported electronic charts. • Updated details relating to LightHouse charts. • Updated chart app to include details of S-63 encrypted charts support. • Updated chart settings table to clarify chart vendor support for different settings. • Added Evolution autopilot commissioning procedure (Dockside wizard). • Merged Dashboard app data item table and Sidebar/Data overlay data item tables. • Added AnyDesk and Oscar to list of pre-loaded LightHouse 3rd party apps.

Document revision and (Date)	Software version	Changes
81370-16 (06-2020)	LH3.12 (R2)	<ul style="list-style-type: none"> • Added Axiom+ to screen resolutions • Added details regarding end of support for eS/gS Series MFDs. • Updated Sidebar details and image. • Updated Chart object information details to include new Cursor info boxes setting changes. • Updated Find nearest details in Chart app to include new Nearby objects options. • Updated chart chapter to include new measurement feature. • Added details of new AIS names options and Auto find ship setting. • Added details of new Fish detection settings tab in Fishfinder. • Updated Yamaha app to include details of Yamaha HDMI. • Updated LightHouse apps to include HP watermaker, Kenetix, Lumitec and Quick Nautical.. • Removed LightHouse 2 to LightHouse 3 upgrade instructions from appendix.
81370-15 (03-2020)	LH3.12 (R1)	<ul style="list-style-type: none"> • Updated NMEA 0183 sentence support and NMEA 2000 PGN support tables. • Added new LightHouse Chart and LightHouse Premium content to the Chart chapter. • Added Display mode content to Shortcuts in the Set up chapter. • Added Color theme (day mode) to Settings table in the Homescreen chapter. • Updated Data overlay and Sidebar data items in the General information chapter. • Updated Memory card compatibility table with exFat card support in the Set up chapter. • Updated Dashboard app graphics in the Dashboard app chapter.
81370-14 (10-2019)	LH3.11	<ul style="list-style-type: none"> • Added new Responder Messaging feature to Homescreen chapter. • Added new iTC-5 Calibration feature to Set up chapter. • Added new Fishidy Sync mobile app to Mobile app support chapter. • Updated SAR patterns with Expanding Square pattern in the Chart app chapter. • Added new Victron app to LightHouse third-party apps chapter. • Updated Video app chapter with Dual streaming. • Added M-Series settings compatibility table to Video app chapter. • Added Pilot track mode and Search route arrival to the Alarm settings table in the Homescreen chapter.
81370-13 (09-2019)	LH3.10.71	<ul style="list-style-type: none"> • Added M300-Series maritime camera to compatible cameras in ClearCruise™ chapter.

Document revision and (Date)	Software version	Changes
81370-12 (07-2019)	LH3.10	<ul style="list-style-type: none"> • Added new camera settings to Video app chapter. • Added new Race Sailing features, Race Start Line and Race Timer to the Chart app and Dashboard app. • Added new Responder setup information to the Homescreen chapter and SITREP feature to Chart app chapter. • Added new SR200 diagnostics to the Audio app chapter. • Updated SR200 network requirements in the Weather mode chapter. • Added new PDF viewer app chapter. • Updated data overlay and sidebar data items table with new wind data. • Added details of new Buoyweather, Shadow-Caster, PredictWind and Offshore to LightHouse™ apps.
81370-11 (04-2019)	LH3.9	<ul style="list-style-type: none"> • Added new Blank sectors to Radar app chapter. • Added ClearCruise™ Augmented Reality support and installation for M100/M200 series thermal cameras to ClearCruise chapter. • Added new Fusion Multi-zone volume control to Audio app. • Updated UAV app with DJI Mavic 2 Pro and DJI Mavic 2 zoom drone support. • Added new RealBathy real-time sonar map generator feature to the Chart app chapter. • Added new Sailing laylines feature to the Chart app chapter. • Updated Dashboard app with sailing page and sailing dials. • Changed Sonar app to Fishfinder app, document wide. • Updated Weather chapter and Audio app chapter with SR200 compatibility. • Updated Boat details section in the Homescreen chapter with new Tank calibration options. • Added new Yamaha engine integration app chapter.
81370-10 (12-2018)	LH3.8	<ul style="list-style-type: none"> • Added new Search and Rescue (SAR) Patterns feature to Chart app chapter. • Added new Collision Avoidance and Target Intercept features to Chart app chapter. • Added Install third-party apps to Lighthouse third-party apps chapter. • Updated Chart app with Chart sync setting. • Added Regulatory approvals to settings. • Updated Limitations on use. • Updated Data Overlays with Loran Data Overlays. • Added Rudder bar to Sidebar. • Updated Audio app with JL Audio compatibility.

Document revision and (Date)	Software version	Changes
81370-9 (09-2018)	LH3.7	<ul style="list-style-type: none"> • Added new ClearCruise™ chapter which documents Object Detection and Augmented Reality. • Added details of new Display estimated range setting for ClearCruise™ Object detection in Video app. • Updated Video app settings menu section with new ClearCruise™ options. • Added details of new Seakeeper and Mazu LightHouse™ apps. • Expanded My data details to include MFD settings import and export (backup). • Added new tasks for Saving user data, saving MFD settings, restoring user data and restoring MFD settings. • Added custom “Digital switching” pages export feature to Dashboard app. • Added AR200 to hardware compatibility table. • Moved Axiom XL compatibility from LightHouse V3.5 to V3.7.
81370-8 81370-7 (07-2018)	LH3.6	<ul style="list-style-type: none"> • Updated software revision and new features section to reflect V3.6. • Added description of each available MFD app to Homescreen section. • Added new UAV app chapter. • Added UAV chart integration details to Chart app chapter. • Updated hardware compatibility list to include Mavic Pro and Mavic Pro Platinum UAVs.
81370-6 (06-2018)	LH3.5	<ul style="list-style-type: none"> • Updated software revision and new features section to reflect V3.5. • Added support for MFD alarms via Bluetooth speaker. • Updated list of compatible entertainment systems in Audio app chapter to include new Fusion units and SR150, also added new column to list supported network connections. • Updated Audio app chapter settings menu options to include Balance and Fade. • Updated Audio app chapter details to allow for multiple systems to be connected and controlled. • Added PDF viewer details. • Updated demo profiles section to detail the new demo movie option. • Updated NMEA 2000 PGN list to include 127506 and 129808. • Updated compatible MFDs to include Axiom XL • Updated product documentation to include Axiom XL installation instructions. • Added new details for using SonarChart Live to Chart app chapter. • Updated LH2 Vs LH3 feature gap on eS and gS Series. • Added LH3 version Vs supported hardware list to appendix. • Updated Radar chapter to include Magnum open array details. • Added new details/requirements for LH apps.

Document revision and (Date)	Software version	Changes
81370-5 (02-2018)	LH3.4	<ul style="list-style-type: none"> • Added LightHouse 2 to LightHouse 3 upgrade procedure to applicable documents. • Updated software revision to V3.4. • Updated New features section to reflect V3.4 new features. • Change chapter title for 'General app settings' to 'General information'. • Added new definition of MFD app and LightHouse app to General info chapter. • Updated shortcuts page details to include Bluetooth speaker volume control. • Added new Bluetooth volume control instructions. • Added new Bluetooth speaker pairing procedure. • Updated Homescreen screenshots to reflect LH3.4 UI throughout the manual. • Updated Homescreen overview to include details of Apps icon. • Updated status area details to include Bluetooth volume controls and Disengage autopilot icon. • Added Bluetooth and Disengage autopilot icons to Status area table. • Removed Wi-Fi symbols from status area icons table and grouped icons in separate tables. • Updated trip log details to include new combined Fuel/trip manager details and settings. • Alarms section re-written to include examples of Blue, Orange and Red notifications. • Added Alarm history and Alarm indicators to Alarms section. • Added Digital switching alarm details and example screenshot. • Added Shared brightness details. • Added procedure for customizing the splashscreen. • Added new LightHouse apps chapter, including Wi-Fi and Bluetooth connection and settings.. • Updated Disengaging autopilot details to include Status area location of autopilot icon. • Added new Tides mode details. • Added new Find nearest feature details. • Added new 'Other' vessel AIS icon and Changed current 'Other' icon to 'Commercial'. • Updated Radar chapter to include Quantum 2 support. • Added Doppler Radar feature. • Updated Fuel related data items available in Dashboard app. • Updated Camera app overview to include details of creating unique app instances on different displays. • Renamed 'Camera app' now 'Video app'.

Document revision and (Date)	Software version	Changes
81370-4 (11-2017)	LH3.3	<ul style="list-style-type: none"> • Updated New features list to reflect LH3.3. • Added RV transducer calibration details. • Added MFD controls information for eS Series and gS Series. • Added new LH3 compatible MFDs table. • Updated Radar target tracking to include AIS targets. • Updated Radar target settings information to include independent Reference mode for targets, and new Trails settings. • Added new Weather mode chapter. • Updated User interface languages table. • Added lists of data items available in Dashboard app and for data overlays and sidebars. • Added Navionics plotter sync details to Mobile app chapter. • Added diagnostic product information details to troubleshooting chapter. • Added LH2 to LH3 upgrade procedure to Appendix. • Updated RV Depth and intensity setting details. • Updated shortcuts page information to include new Disable all sounders option.
81370-3 (09-2017)	LH3.2	<ul style="list-style-type: none"> • Updated software revision to reflect LH3.2. • Updated New features section to reflect LH3.2. • Added User programmable button details for Axiom Pro MFDs. • Updated Software updates section to reflect updating SeaTalkng products. • Added wireless display information, connection details and troubleshooting. • Added NMEA0183 setting for Axiom Pro MFDs. • Added Autorouting related information and procedures. • Updated Chart selection information to include C-MAP cartography. • Added AIS symbols tables. • Updated Chart settings tables to include C-MAP specific and Enhanced Navionics cartography features support. • Added Sailing and Navigation dial overview to Dashboard chapter. • Updated Camera app overview to include analog feeds via an Axiom Pro. • Updated Audio app compatible entertainment systems to include compatible Rockford Fosgate and Fusion units. • Updated Radar troubleshooting to include high network bandwidth. • Added NMEA0183 supported sentences table.
81370-2 (07-2017)	LH3.1	<ul style="list-style-type: none"> • Updated software revision to reflect LH3.1. • Added controls details for Axiom and Axiom Pro • Added powering on and off details for Axiom Pro. • Removed Data source type table from Data sources. • Re-ordered Data source and MDS paragraphs. • Moved Factory reset procedure to para 3.3. • Added Pilot controls to shortcuts page. • Re-ordered memory card paragraphs and added details for Axiom Pro.

Document revision and (Date)	Software version	Changes
		<ul style="list-style-type: none"> • Added details for software updating networked MFDs. • Removed restriction of RMK pilot button in LH3 and added new step for repeating pairing process on each MFD. • Updated Homescreen overview to include Disengage pilot icon. • Added Wi-Fi sharing and Mobile app details to This display setting tab. • Added new Autopilot tab to Settings menu. • Added table of available UI languages. • Removed device disconnection details from External devices options. • Added new Autopilot control chapter. • Added details for switching between Sidebars. • Added camera tracking (Point camera here and Track with camera controls to Chart and Radar chapters. • Added details for placing waypoints in RV channels. • Added details of Sonar scroll back. • Added details of sensitivity adjustments effecting sonar scroll back. • Added View mode in RV channel settings to switch between scrolling and GPS tracking modes. • Added details of AHRS stabilization control in Sounder tab settings. • Added new Mobile app support chapter. • Added document change history to appendix.
81370-1 (04-2017)	LH3.0	First release.

Appendix D Hardware compatibility

The table below identifies the LightHouse™ 3 software version required to support the listed hardware.

Software version	Hardware
LH3.14.88	<ul style="list-style-type: none"> • RMK-9 / RMK-10 — Software platform V18.xx / Software application V20.xx. • CP100 / CP200 — Software platform V18.xx / Software application V20.xx. • CP370 / CP470 / CP570 — Software platform V18.xx / Software application V20.xx. • RVX1000 — Software version 3.14.88.
LH3.12	<ul style="list-style-type: none"> • Axiom+
LH3.11	<ul style="list-style-type: none"> • Victron Energy Venus GX
LH3.10.71	<ul style="list-style-type: none"> • M300-Series
LH3.9	<ul style="list-style-type: none"> • SR200 SiriusXM receiver (weather and audio) • DJI Mavic 2 Pro UAV • DJI Mavic 2 Zoom UAV
LH3.8	<ul style="list-style-type: none"> • JL Audio
LH3.7	<ul style="list-style-type: none"> • AR200 Augmented Reality Sensor • Axiom XL
LH3.6	<ul style="list-style-type: none"> • DJI Mavic Pro UAV • DJI Mavic Pro Platinum UAV
LH3.5	<ul style="list-style-type: none"> • Fusion 770 and SRX400 • SR150 SiriusXM receiver (audio)
LH3.4	<ul style="list-style-type: none"> • Magnum Radar • Quantum 2 Doppler Radar • RVX1000 sonar module • Bluetooth speaker • Axiom XL 16
LH3.3	<ul style="list-style-type: none"> • SR150 SiriusXM receiver (weather only) • eS Series (upgraded to LH3) • gS Series (upgraded to LH3)
LH3.2	<ul style="list-style-type: none"> • Axiom Pro • Fusion entertainment systems (NMEA 2000 only)
LH3.1	<ul style="list-style-type: none"> • Evolution autopilots • RMK-10 • Quantum Radar
LH3.0	<ul style="list-style-type: none"> • Axiom

Index

A

Activate Touchlock	50
ActiveCaptain	200
Adjust for tides	203
Adjust Locked heading.....	50
Advance waypoint.....	105
AIS	198
Buddy	147
Enhanced AIS targets	204
Silent mode.....	67, 147, 272
Target icons.....	143, 269
Target list.....	147, 268
Target options	146
Target tracking.....	268
AIS PAD	199
AIS targets	142
AIS names.....	147, 272
AIS types.....	147, 272
Blue force	220
Enhanced AIS targets	147, 272
Enhanced icons	143, 270
Enhanced target status.....	144, 271
Show.....	147, 272
Static targets.....	147, 272
AIS, Buddy.....	347
Alarm manager	77
Alarms	61, 77
Acknowledgement.....	80
Active.....	77
AIS safety messages.....	80
Anchor drift.....	80
AX8 camera.....	80
Cross track error (XTE).....	80
Dangerous	77
Dangerous AIS targets.....	79
Dangerous Radar targets.....	79
Deep water arrival	80
Digital switching.....	80–81
DSC.....	80
Engine.....	80
External speaker	80
Fishing range	80
Guard zone 1.....	79
Guard zone 2	79
History.....	78
Lost Radar targets.....	79
Low fuel	80
MOB data type.....	80
Obstruction	161
Off track	80
Settings.....	79
Shallow water arrival.....	80
Warning	77
Water temperature.....	80
Waypoint arrival	79
Aligning the rudder.....	98
Animated weather	230
AnyDesk	389
App launcher	388
App page icons	61
App pages	
Creating	63
Customizing.....	63
Applications.....	61
Apps	61
LightHouse	26
MFD	26
AR200	352
Calibration.....	352
Audio app.....	62, 363
app controls.....	358
Balance.....	365
Crossover	365
Diagnostics mode.....	366
Fade.....	365
Menu options.....	364
Multi-zone	367
Multi-zone control.....	366
Opening.....	361
Player controls	358
Reset.....	366
Settings.....	365
Source	363
Zones.....	362
Audio controls	358
Audio receiver	356
Audio sidebar	360
Augmented Reality	336
AIS targets	348
AR200 setup.....	341
Camera installation and setup	337
Cartography source	348
ClearCruise settings	348
Compass bar.....	348
Flags	344–345
Goto flag.....	347
Range limit.....	348–349
Roll correction.....	350
Troubleshooting	415
Waypoints	348
Augmented Reality, camera FOV	338
Augmented Reality, Overview.....	344
Auto acquisition	
Data source requirements	273
Auto turn.....	107
Automatic linearization.....	353
Autopilot	
Adjust locked heading.....	50
Advanced settings	106
Control	102
Debug.....	107
Disengage	104–105
Engage or Disengage.....	50
Engaging.....	103
Pop-ups.....	106
Reset.....	107
Shortcuts.....	51
Sidebar	104
Standby.....	104
Status.....	105
Autopilot set-up	
Deadband angles	109
Rudder Damping.....	109
Autorouting.....	116

B

Back up	
Settings	75
User data	75
Backup	
MFD settings	76
Routes	75
Tracks	75
Waypoints	75
Barbs	238
Battery	30, 292
Battery data	30, 292, 307
Battery selection	86
Bearing mode	298
BeiDou	69
Bird mode	265
Blue Force	
AIS targets	220
Bluetooth	
Audio	57, 394
Connection	393
Disabling	393
Enabling	393
pairing speaker	57, 394
Settings	393
Speaker volume	51, 394
Volume	50, 388
Boat data	30, 292, 306–307, 309
Boat details	85
Tanks	
Calibration	86–88
Calibration points	87
Boat Icon	85
Boat name	85
Boat type	85, 203
Bright sun	198
Brightness	50, 52, 89
Buddy, add to list from AR flag	347
Buoy mode	265

C

Calibration	352
iTC-5	47
Linearization	352
RealVision™ 3D	46
transducer	47
Calibration lock	107
Calibration, reset	353
Camera	
Tracking	129, 258
Cartography	198
Chart	201
Aerial overlay	199
Auto find ship	204
Boat position	203
Cartographic objects	204
ClearCruise	194
Contours	200
Controls	123
Current animation	165
Current graph	167
Current station	167
Cursor info boxes	204

Detailed mode	125
Field of View (FOV)	195
Find nearest	171
Fishing mode	125
Layers	128, 198
My data appearance	205
Race Start Line	190
Race Start Line and Race Timer	189
Racing mode	125
Radar overlay	204
Radar settings	150
RealBathy	170
Safe contour	201
Search for objects	171
Shallow area	201
Shallow contour	200
Show soundings	200
Simple mode	125
Sync view with other charts	203
Tide animation	165
Tide animation interval	204
Tide bar	167
Tide graph	166
Tide graphic	167
Tide station	166
Tides	199
Tides mode	125, 165
Weather mode	125
Chart / Radar Sync	150
Chart app	62
Laylines	184
Chart appearance	205
Chart appObject information	
Cursor info boxes	127
Chart detail	198
Chart motion	202
Auto range	202
Relative motion	202
True motion	202
Chart Object Size	198
Chart orientation	203–204
Course-up	203–204
Head-up	203–204
North-up	203–204
Chart style	198
Chart,	
Modes	124
Checking rudder drive	99–100
Cities layer	233
ClearCruise	
Augmented Reality	339
Augmented Reality (AR)	336
Object detection	336, 341–342
Coastal mode	265
COG / SOG filter	71
Collision avoidance	
Course change	155, 158
Moving target	153
Predicted Area of Danger zone	152
Predicted areas of danger	154
Speed change	156, 159
Stationary target	153
Color gain	249
Commissioning pre-requisites	96

Commissioning steps	96
Community edits.....	200
Compass	
Alignment.....	107
Linearization	352–353
Lock	107
Offset	106
Restart.....	107
Compass linearization	96
Compass lock.....	96, 102, 353–354
Compass offset.....	353
Compatible entertainment systems.....	356–357
Compatible hardware	437
Connecting	
RayControl	402
RayRemote	403
RayView.....	404
Connection	
NMEA 0183	92
Connections	
Bluetooth	393
Internet	391
Wi-Fi.....	392
Contact details.....	422
Controls	
Chart.....	123
Dashboard	290
Fishfinder.....	242
Radar	256
Video app	323
Yamaha app.....	305
CPA	279
Cross track error.....	138
Cruise speed	106
CSP (Commence Search Point)	176, 179
Current reading	353
Cursor info boxes	127
Customizing sidebar.....	27
D	
Dangerous targets alarm.....	152
Dashboard	
Controls	290
Dashboard app.....	62
Data.....	30, 292, 306, 308
Battery	307
Boat	30, 292, 306–307, 309
Depth.....	30, 293
Display.....	30, 293
Distance.....	30, 293, 306, 308
Engine.....	31, 293, 306, 308
Environmental.....	31, 294, 306, 309
Fuel.....	31, 294, 306, 308–309
GNSS (GPS).....	32, 294, 306–307
Heading	32, 295, 307
Inside Environmental	31, 294
Navigation.....	33, 295, 308
Pilot.....	33, 295, 306, 308
Speed	33, 296, 306, 308
Tank	34, 297
Time.....	33, 296, 308
Wind.....	34, 297, 309
Data import and export	72
Data items	
Data overlays.....	29, 292
Sidebar	29, 292
Data master	89
Designation.....	89
Multiple	43
Selection.....	43
Data overlays.....	29, 292
Data sources	44
Selection.....	44
Day color palette	198
Deadband angles.....	109
Deep contour	201
Deep water color.....	201
Delete rulers.....	175
Demo	
Movie	66
Profiles.....	66
Demo movie	
format.....	66
Density	201–202
Depth.....	306, 308
Depth contour	
Options	140
Depth contours.....	140
Depth data.....	30, 293, 306, 308
Depth gradient	201
Depth offset.....	45
Depth soundings	
Options	139
Units.....	139
Deviation	353
Diagnostics.....	423
Product info	406
Digital switching	
Exporting pages.....	297
Importing pages.....	297
Disable all Sounders.....	50
Display data.....	30, 293
Display Layines on this chart.....	203
Display mode.....	50, 52
Distance data	30, 293, 306, 308
Dock-to-dock.....	116
DockSense app	63
Dockside wizard.....	96, 107
Document history	429
Documentation.....	22
Doppler.....	150
Data source requirements	283
Overview.....	282
Downwind angle.....	85
Drive polarity	108
Drive type	97, 106
DSC	
Target list.....	214
Target options	213
DSC notifications	82
DSC targets	142, 213
E	
Easy Routing.....	116
Easy View	200
Eject SD card.....	50–51

Engage / Disengage autopilot.....	50
Engine	
Fault codes	319
Engine connection wizard	85
Engine data	31, 293, 306, 308
Engine identification wizard	44
Engine manufacturer	86
Engine quad display	86
Engine selection	85
Entertainment systems	356
Environment data	31, 294, 306, 309
Environment sensors	86
Export	
Routes	75
Settings	75
Tracks	75
User data	75
Waypoints	75
External devices	61
External storage	
Eject SD card	50
Inserting	55
Removal	55

F

Factory reset	407–408
File browser.....	75
First power up	42
First responder	208
AIS mode	209, 219
Boat name	208
Data logging	209–210
FID	209
FID checksums	209
Messages app	63, 72
MMSI.....	208
OneShot TOI settings	209
Passphrase	209
SITREP	220
Vessel type	208
Fishfinder	
Fish depth labels.....	253
Fish detection	253
Fish detection sensitivity.....	253
Fish icons.....	253
Zoom mode	243
Fishfinder app.....	62
App overview.....	242
Auto range	243
Channels.....	247
Controls	242
No source	245
No transducer	246
Range	243
Scroll back	248
Waypoints	247
Fishing AOI	200
Fishing range.....	202
Fixed angle	
Downwind angle	203
Upwind angle.....	203
FOV layer	199

Fuel data.....	31, 294, 306, 308–309
Fuel manager	72–73
Set-up	74
Fusion.....	357

G

Galileo	69
GLONASS	69
GNSS / GPS	61
GNSS (GPS)	70
COG / SOG filter	71
Constellations	71
Differential positioning.....	71
Internal receiver.....	72
SBAS.....	71
GNSS (GPS) constellations.	68
GNSS (GPS) data	32, 294, 306–307
GNSS (GPS) Settings	71
GNSS/GPS troubleshooting.....	410
Goto waypoint	138
GPS.....	69–70
gpx.....	75
GRIBview	389
Guard zone alarms	280
Gybe	108

H

Harbor mode	265
Hard over time.....	108
Hard-over time	96, 99
Heading data.....	32, 295, 307
Height correction.....	201
High res bathy	200
Homescreen.....	61
HP Watermaker	389

I

Import	
Settings.....	75
User data	75
Import tank calibration.....	88
Import/export.....	72
Initial setup	42
Intel	
Target list.....	212
Targets	211
Intel target	
Target options	212
Intel targets.....	142
Internet connection	391
IP address.....	423
IRPCS / COLREGS	152
iTC-5 calibration	47

J

JL Audio	357
----------------	-----

K

Kinetix.....389

L

Languages.....85

Selection.....84

Laylines 184, 188–189

displaying and interpreting187

enabling.....185

Settings.....186

system requirements185

Wind shifts188

LightHouse 3

Compatible MFDs22, 437

LightHouse™ 3

Tips and Tricks424

LightHouse™ charts

Premium.....131, 398

LightHouse™ charts

Premium subscription61

Lighthouse third-party apps

Install.....391

LightHouse third-party apps.....388

AnyDesk389

Background app388

Downloadable.....391

GRIBview389

HP Watermaker.....389

Kinetix389

Lumishore389

Lumitec389

Mazu390

Netflix.....390

Oscar390

Preloaded389

Quick Nautical.....390

Seakeeper390

Shadow-Caster390

Spotify.....390

Victron Energy390

Limitations on Use60

Limitations on Use (LoU).....60

Linearization352–353

Locked heading.....103, 106

Lumishore.....389

Lumitec.....389

M

Magnetic deviation352

magnetic interference352

Man Overboard (MOB)81

Marine protected areas200

MARPA

Data source requirements273

Mazu.....390

Measure.....173–174

Media files72

Memory cards

Compatibility.....53

Menus

Settings.....36, 83

Types34

Mercury

VesselView fault codes319

Message inbox223

Messages

Broadcast reply.....224

Character limit.....223

Export223

link ID.....224

New broadcast.....223

New direct message.....223

Received.....223

Reply.....224

Sent.....223

Messages app63, 72, 222

Messaging app.....63

MFD

Buttons.....38

Controls38

MFD alarms388

MFD apps61

Audio app62

Chart app62

Dashboard app62

DockSense app63

Fishfinder app62

Messages app63, 72

Messaging app63

PDF viewer app63

Radar app62

UAV app62

VesselView app.....63

Video app62

Yamaha app.....63

Yamaha HDMI app.....63

MFD settings

Import.....76

Restore76

MicroSD

Adaptor53

Inserting.....54

Removal.....54

Minimum safe depth.....116

Minimum safe height117

Minimum safe width.....117

Miracast.....92

MMSI number223

MOB61

Mobile apps.....396

RayConnect397

Motor phasing108

Multiple data sources (MDS).....44

Mute363

My data.....61, 72

N

Navigation data33, 295, 308

Navigation mode103, 106

Navionics plotter sync402

Netflix390

New features23

NMEA 0183

Baud rate92

Supported sentences425

NMEA 2000..... 426
Notifications..... 77

O

Object detection..... 341
 ClearCruise settings 342
Object information..... 127
Obstruction alarm 161
 Parameters..... 161
Offshore mode 265
Oscar 390

P

Pairing
 Quantum radar..... 57
 RMK keypad..... 57
PDF..... 75
PDF Viewer
 controls 371
 Opening files 370
 Overview..... 370
 Searching a PDF 372
PDF viewer app 63
PGNs 426
Pilot data..... 33, 295, 306, 308
Pilot icon..... 103
Pilot sidebar..... 103
Point camera here 129, 258
point to point 174
Polar 85, 203
Position..... 70
Power off 50
Power steering 107
Power troubleshooting 407
Powering off 41–42
Powering on 40–41
Premium subscription..... 61
Primary MFD..... 89
Product information..... 423
Product support..... 422
Profiles..... 61

Q

Quick Nautical 390

R

Race Start Line 189
 based on waypoints..... 190
 creating..... 190
 editing or deleting..... 192
Race Timer 189
 starting..... 192
Radar 149, 199, 276
 Antenna size selection..... 264
 Bearing alignment..... 264
 Blank sectors 283
 Color Gain..... 285
 Comparison 258
 Compatible scanners..... 261
 Controls 256

Dual range 150, 263
Dual range channel..... 150
Features..... 258
Gain 284
MARPA 148, 274
Modes 264
Overlay 150
Overlay color palette 150
Overlay visibility..... 150
Overlay without heading..... 151
Powering off..... 262
Rain 284
Range 151
Range and Bearing 266
Sea..... 285
Sector blanking..... 150
Selecting a scanner 263
Selection 150
Sensitivity controls..... 284
Settings..... 285
Standby..... 262
Stop transmitting..... 50
Target options 149
Target settings..... 277
Timed transmit 264
Transmit 150
Radar app 62
Radar Doppler
 Color palettes 282
 Mode..... 282
Radar PAD 200
Radar target
 Automatic acquisition 275–276
 Cancel target 279
 Cancel targets..... 150, 277
 Clear trails..... 279
 Context menu 279
 History..... 278
 Information..... 279
 Manual acquisition 148, 274
 Reference mode 277, 279
 Relative mode..... 277
 Shown CPA 279
 Symbols 147, 273
 Tracking 273
 Trails (Wakes)..... 279
 True mode 277
 Vectors 278
Radar targets..... 142
Radar troubleshooting..... 409
Range rings 199
RayControl..... 396, 402
RayRemote 396, 403
RayView..... 396, 404
RealBathy 170, 201
 Chart 171
 Density..... 171
 Height correction 171
 RealBathy..... 171
 Visibility..... 171
 Waterline to tdc 171
RealVision 3D
 Controls 243
 Waypoints 247

Receiver status.....	229	Search and Rescue, See SAR	
Record depth data.....	201	Secure messaging.....	222
Recovery mode.....	407–408	Service Center.....	422
Regulatory approvals.....	20	Settings.....	61
Responder		Settings menu.....	83
Settings.....	208	Regulatory approvals.....	20
Rockford Fosgate.....	357	setup.....	208
Route.....	114	Shadow-Caster.....	390
Capacity.....	114	Shallow depth shading.....	202
Creation.....	114	Shared brightness.....	89
Follow.....	138	Shortcuts menu.....	50
Follow from here.....	139	Show contours.....	200
Importing.....	117	Sidebar.....	27
List.....	72, 117	Pinning.....	28
Rudder		Selection.....	28, 104
Damping.....	107	VesselView.....	320
Limit.....	108	Sidebars	
Offset.....	108	Audio.....	360
Reverse reference.....	107	Simulator, See Demo	
Rudder bar.....	105	SiriusXM.....	356
Rudder Damping.....	109	SiriusXM weather.....	228
Rudder limit.....	98	Slew to Cue.....	129, 258
Ruler.....	173	SmartStart.....	189
		Software	
S		Compatible MFDs.....	22, 437
S-63 Encrypted Charts.....	133	Software updates.....	56
Base cells.....	135	Software version.....	22
Cell permits.....	135	Sonar	
Chart app settings.....	137	Channel selection.....	244
Cumulative update files.....	136	Disable all sounders.....	50
Expiry.....	137	Gain.....	249
Installation process.....	133	History.....	248
Installed charts.....	137	Intensity.....	249
MFD activation file.....	134	Noise filter.....	249
Purchasing.....	135	Sensitivity controls.....	249
Scheme administrator certificate.....	134, 137	Surface filter.....	249
SSE-06 notification.....	134	TVG (Time Varied Gain).....	250
SSE-22 notification.....	134	Sonar logs.....	202
Update charts.....	137	SonarChart Live.....	197, 202
User permit.....	137	Enabling.....	198
User permits file.....	135	Tide correction.....	197
Safe depth, minimum.....	85	Speed data.....	33, 296, 306, 308
Safe distance.....	152	Speed input.....	106
Safe height, minimum.....	85	Splashscreen customization.....	91
Safe width, minimum.....	85	Splashscreen reset.....	91
Sail performance.....	85	Splashscreen resolution.....	91
Sail Performance.....	203	Sports fishing.....	200
SAR.....	175	Spotify.....	390
creation.....	176, 179	Startup wizard.....	43
pattern.....	175	Status area.....	66
Sector search pattern.....	176	Status area icons.....	67
SAR Pattern		Steer to Hdg.....	105
Drifts effects.....	178, 181	Steer to Nav.....	105
Save settings.....	76	Stop Radar transmitting.....	50
Save to.....	201	Storm cast.....	235
Saving		Storm tracks.....	235
Product information.....	406	Streets & POI.....	199
SBAS.....	71	Support forum.....	424
Screen mirroring.....	92	Surface observation stations layer.....	233
Screen resolutions.....	91	Surface pressure	
Screenshot.....	50	Animated.....	231
Sea surface temperature.....	236	Switching off.....	41–42
Seakeeper.....	390	Switching on.....	40–41
		System Datum.....	298

T

Take Screenshot	50
Tank calibration	86
Tank data.....	34, 297
Target list.....	149, 276
Target of Interest (TOI)	
OneShot.....	217
Position updates	217
Received	215
Repeating	217
Sent.....	215
Target icons	214
Transmission rate.....	217
Target options	146, 148, 212–213, 217
Target tracking	142
AIS	142
DSC.....	142
Intel.....	142
Radar	142
TOI	142
Targets	
Intel.....	211
Targets of Interest	142
Technical support.....	422, 424
Thermal camera	
Tracking	129, 258
third-party apps	
LightHouse third-party apps	388
Third-party apps	388
Tide correction	202
Tide height	167
Tides mode	
Animation controls.....	165
Displaying graphs	169
Time data.....	33, 296, 308
Time to Burn.....	189
Time/Date format.....	88, 298
TOI	
OneShot decay	216
OneShot decay times	216
OneShot Delay	216
Target list.....	218
Touchlock	50
Track with camera	129, 258
Tracking	
Thermal Camera	129, 258
Tracks	118
Capacity.....	118
Creation	119
Customize.....	120
Interval	120
List	72, 120
Trails clearing	279
Trails reset.....	279
Training courses.....	424
Transducer	
Configuration	45
Selection.....	45
Setup	45
Temperature calibration	45
Temperature settings.....	45
Trip	
Counter.....	72

Trip logs.....	73
Troubleshooting	406
Augmented Reality	415

U

UAV	199
App	381
App overview.....	374
Assuming control.....	386
Chart icon	196, 384
Chart integration.....	196, 384
Circle me.....	383
Compatible devices	375
Connection	377
Controller RC Cable.....	377
Controller signal lost.....	385
Controls	382
Critical battery.....	386
Disclaimer	374
Disconnect.....	383
Emergency procedures	385
Fish on	383
Flight.....	382
Flight data.....	375
Getting started	379
Goto	197, 385
Icon.....	197, 385
launching	382
Low battery	386
Manual control	386
No connection	380
No-fly zone.....	378
pre-requisites.....	376
Precautions.....	378
Record	374
Registration failed.....	381
Restricted airspace	378
Retrieval.....	383
Set up sequence.....	379
Settings.....	375
Split-screen page.....	379
Sport mode	375
Status area.....	375
Take off.....	382
Take photo.....	374
vectors	196, 384
Virtual joysticks.....	375
UAV app.....	62
Uni-controller	
Functions	39
Units	88, 298
Unmute.....	363
Unpairing	
RMK keypad.....	57
Upgrading, software.....	56
Upwind angle	85
User data	72
Import.....	76
Restore	76
Back up	75
User interface	
Languages	84
User programmable button (UPB)	49

V	
Variation	298
Vessel hull type	96, 106
Vessel Hull Type	96
Vessel to point.....	174
VesselView	
Sidebar	320
VesselView app.....	63
Victron Energy.....	390
Video.....	322
Feed selection	325
Renaming feeds.....	323
Video Analytics.....	341–342
Video app.....	62
Controls	323
Video app pages	322
Video Gallery.....	424
Video, viewing multiple inputs.....	322
Visibility	201–202

W	
Warranty	422
Watchbox alerts.....	239
Waterline to tdc.....	201
Wave direction	
Animated	231
Wave height	
Animated	231
Wave period	
Animated	231
Waypoint	112
capacity.....	112
DSC.....	83
Goto.....	138
List	72
Placement.....	247
Waypoint, place from AR flag	347
Weather	
Settings.....	205
Weather data date.....	229
Weather layers	228
Weather mode.....	228, 265
Weather Radar	
Animated	230
Weather Radar layer.....	199
WeatherMarine zone boundaries.....	205
WeatherReceiver ESN	205
WeatherSignal strength.....	205
WeatherWatchbox alerts	205
WeatherWatchbox range.....	205
WeatherWind symbol	205
Wi-Fi	
Settings.....	392
Wind	
Data type	108
Shift.....	108
Wind arrows.....	238
Wind data	34, 297, 309
Wind direction	238
Animated	230
Wind fields.....	235
Wind Radii	235
Wind speed	238

Wireless display.....	92
-----------------------	----

X

XTE,	
Restart.....	138

Y

Yamaha app	
Controls	305
Yamaha app	63, 304, 306
Advanced.....	315
data items	306
Data page	307
Engine instances reset.....	315
Engine page.....	306, 309
Engine trim.....	313
Fuel flow offset	315
Gateway reset.....	315
Overview.....	304
Requirements	305
Settings.....	314
Status	
Engine warming up	312
Immobilizer lock	312
Synchronization.....	312
Status indicator	312
Tanks	313
Tanks page	309
Transmission	311
Trim Calibration	315
Troll mode.....	314
Warning	
Catalyst	313
Check engine warning	313
Low oil pressure.....	313
Low voltage.....	313
Overheat	313
Steering system	313
Water in fuel.....	313
Warning indicator.....	313
Yamaha gateway.....	304
Yamaha HDMI	304
Yamaha HDMI app	63



Raymarine

Marine House, Cartwright Drive, Fareham, Hampshire.
PO15 5RJ. United Kingdom.

Tel: +44 (0)1329 246 700

www.raymarine.com

Raymarine®

a brand by  **FLIR®**